

# ELECTRIFYING THE BROADS

Clean Maritime Demonstration Competition

Damian Baker, Michael Brown, Mary Copsey, Charlotte Farmer,  
Nigel Hargreaves, Fiona Keysell, James Knight, Harry Mach,  
Paul Newlove, Andrew Verney

10008242

Electrifying the Broads

[nigel@synfo.co.uk](mailto:nigel@synfo.co.uk)

## Contents

<b>Contents</b>	<b>2</b>
<b>Glossary</b>	<b>14</b>
EV charging connector types	<b>15</b>
Rapid chargers	15
Fast chargers	15
<b>PUBLIC EXECUTIVE SUMMARY</b>	<b>16</b>
Objectives	16
Detailed and costed demonstration plan	16
Compliance with regulation	17
Lifecycle emissions savings	17
Economic impacts	17
Barriers to commercial adoption	18
<b>EXECUTIVE SUMMARY</b>	<b>19</b>
Objectives	19
Detailed and costed demonstration plan	19
Compliance with regulation	20
Lifecycle emissions savings	20
Economic impacts	20
Barriers to commercial adoption	21
<b>INTRODUCTION</b>	<b>22</b>
<b>3.1 Background to the Broads</b>	<b>22</b>
<b>3.2 Importance of the proposed project and demonstration</b>	<b>23</b>
<b>3.3 How this project fits with a clean maritime future</b>	<b>24</b>
<b>OBJECTIVES OF THIS FEASIBILITY STUDY</b>	<b>27</b>

Figure 4.1: The ETB challenges represented as a trilemma	27
Table 4.1: Outline of objectives in the ETB feasibility study	27
<b>PLAN FOR A FUTURE DEMONSTRATION PROJECT</b>	<b>29</b>
<b>5.1 Description of demonstration project</b>	<b>29</b>
High level demonstration timeline	30
Figure 5.1: High-level demonstration timeline	30
<b>5.2 Objectives of the demonstration project</b>	<b>30</b>
<b>5.3 Technical approach</b>	<b>31</b>
Figure 5.2: Key stages in the technical approach leading to the demonstration	32
Figure 5.3: A President class hire vessel and dimensions	34
Figure 5.4: Powertrain overview	36
5.3.1 Description of the demonstration project	36
Figure 5.5: Overview of key stages of ETB Phase 2 demonstration	37
Prepare demonstration vessel	37
Prepare charging infrastructure	38
Table 5.1: Locations of chargers in the proposed demonstration project	39
Conduct demonstration and evaluation	40
Data analysis	40
User experience, social and economic analysis	41
Customer feedback surveys and interviews	42
Booking and market analysis	42
Economic impact comparison	43
<b>5.4 Business case</b>	<b>43</b>
5.4.1 Business case introduction	43
Drivers for change	43
Options Considered	45

Table 5.2: Demonstrator options and deliverables	46
5.4.2 Business growth plans	47
5.4.3 Business case challenges	48
Table 5.3: Impacts on the business case	48
5.4.4 Potential for value stacking using MEV batteries	49
5.4.4.1 Value stacking example - Revenue potential per boat (2019 values)	51
Assumptions and context	51
Scenario One	51
Scenario Two	52
<b>5.5 Costs and funding requirements</b>	<b>53</b>
Table 5.4: Summary costs for Phase 2 demonstration	53
Why demonstration funding is required	53
Funding Requirements	54
Estimates and Contingencies	54
<b>5.6 Permits and permissions</b>	<b>55</b>
5.6.1 Permits	55
Lighting	56
Figure 5.6 - Dark Sky Areas in the Broads	57
<b>5.7 Delivery timescales</b>	<b>58</b>
<b>5.8 Required collaboration and partners</b>	<b>59</b>
<b>CONSIDERATION OF REGULATION</b>	<b>60</b>
<b>6.1 Maritime decarbonisation policy against the backdrop of Net Zero 2050</b>	<b>60</b>
6.1.1 Maritime decarbonisation examples	61
<b>6.2 Local activity relevant to Net Zero 2050</b>	<b>62</b>
<b>6.3 Potential interactions with regulation and regulators</b>	<b>62</b>
Figure 6.1: A representation of the five principal areas of regulatory influence	63

6.3.1 Advisory only	63
6.3.2 National frameworks - Boat Safety Scheme	64
6.3.3 National frameworks - Planning	65
6.3.4 National frameworks - Charging infrastructure	65
6.3.5 Local accountable body - the Broads Authority	66
Navigation Bylaws	66
Hire Boat Licensing	67
Planning - The Broads Local Plan	68
Planning - Permitted Development	69
Planning - Permissions for waterside development	70
6.3.6 Local accountable body - UKPN (Distribution Network Operator)	70
<b>6.4 Discussions with regulators</b>	<b>71</b>
Table 6.1: Summary of engagement with regulatory bodies	71
<b>6.5 Summary of issues that may be encountered at the demonstration phase</b>	<b>72</b>
Table 6.2: Regulatory issues that could be encountered in the proposed demonstration	72
<b>LIFECYCLE EMISSIONS</b>	<b>73</b>
<b>7.1 Challenges in quantifying emissions from inland waterways leisure vessels</b>	<b>73</b>
Table 7.1 National boat licence types and numbers on Canal and River Trust waterways	73
Figure 7.1. Distances travelled by inland waterways vessels (AINA data, 2016)	74
<b>7.2 Approach to estimating greenhouse gas emissions savings from vessels on the Broads</b>	<b>75</b>
Table 7.2: UK Government conversion factors used in GHG assessments	75
7.2.1 Lifecycle emissions	76
Figure 7.2: Summary of approach to calculating reported emissions parameters	78
7.2.2 Approach to fossil fuel GHG emissions on a per unit basis	79
Central case for cruise duration	80

Figure 7.3. NBD holiday durations 2018-2020	80
Table 7.3: NBD hire cruiser bookings	80
Estimating the central case for fossil fuel demand	80
Figure 7.4: Subsystems from a typical Broads holiday cruiser	81
Table 7.4: NBD boat hire fuel usage by month (2018)	82
Figure 7.5: Fuel use for 3, 4 and 7-night hires respectively (2018-2020)	83
7.2.3 Per unit emissions from central case - fossil fuel systems	84
Formula 1:	84
Formula 2:	84
Table 7.6: Per unit emissions for a Broads hire cruiser based on NBD data (kg GHG/cruise night)	84
7.2.4 Approach to electrical emissions on a per unit basis	85
Figure 7.6: Simplified distribution of marine ICE propulsion system losses	86
Emissions from direct energy demand conversion	86
Table 7.7: Factors used to convert fossil fuels to kWh	86
Formula 3:	86
Formula 4:	87
Table 7.8: GHG emissions from electrical energy equivalents to 50% annual fossil fuel consumption	87
Table 7.9: Per unit emissions for a Broads hire cruiser electrical equivalent based on NBD data	87
(kg GHG/cruise night)	87
Emissions from estimated in-service electrical energy demand	88
Figure 7.7: Schematic showing principal electrical systems replacing fossil fuel dependent systems	88
Table 7.10: Hire cruiser daily energy demand by subsystem	89
Formula 5:	89
Formula 6:	89

Formula 7:	90
Table 7.11: Per unit emissions based on electrical demand estimations over cold and warm conditions	90
7.2.5 Per unit lifecycle emissions savings	90
7.2.6 Estimation of emissions savings over the life of the proposed demonstration project and service life of critical components	91
Formula 8:	91
Table 7.13: Emissions savings for duration of demonstration project and equipment lifespan (tCO <sub>2</sub> e)	92
7.2.7 Approach to estimating operational emissions savings from full technology adoption at scale	92
Table 7.14: Powered vessels licensed to use the Broads in 2021	92
Figure 7.8: Everett Rogers' diffusion of innovation model	94
Table 7.15: Projection of hire fleet MEV technology adoption	95
Figure 7.9: MEV adoption by Broads hire fleet	96
7.2.6 Estimation of emissions saved from holiday hire sector	96
Table 7.16: Emissions savings from Broads hire fleet MEV adoption	97
7.2.7 Estimation of emissions displaced from the wider Broads fleet	98
Table 7.17: Emissions from fuel consumed in 2021 by Broads fleet (includes WTT and operational emissions)	99
Table 7.18: Emissions savings from portions of Broads ICE fleet conversion to clean energy	99
<b>ECONOMIC IMPACTS</b>	<b>101</b>
<b>8.1 Overview of economic context for the Broads</b>	<b>101</b>
<b>8.2 Potential impact on jobs</b>	<b>101</b>
<b>8.3 Potential impact on Gross Value Added to the local economy</b>	<b>103</b>
8.3.1 Tourism	103
Table 8.1: Revenue generated through tourism (overnight stays) - Visit Norfolk 2019	103

8.3.2 Supply chains	105
<b>8.4 Non-tangible benefits</b>	<b>106</b>
8.4.1 Charging infrastructure as a public good	106
8.4.2 Improved water quality	107
8.4.3 Reduced noise pollution	107
8.4.4 Improved air quality	107
<b>8.5 Distribution of benefits by location</b>	<b>108</b>
Table 8.2: Summary on distribution of benefits	108
<b>8.6 Economic impacts over time</b>	<b>108</b>
Table 8.3: Economic impacts over time (demonstrator)	109
Table 8.4: Economic impacts over time (longer term)	110
<b>BARRIERS TO COMMERCIAL ADOPTION</b>	<b>111</b>
Table 9.1: Summary table of barriers to commercial adoption	111
<b>9.1 Explanation of barriers to commercial adoption</b>	<b>113</b>
<b>PROJECT CONCLUSIONS AND RECOMMENDATIONS</b>	<b>116</b>
<b>10.1 Summary conclusions</b>	<b>116</b>
<b>10.2 Emissions conclusions</b>	<b>118</b>
Table 7.13: Emissions savings for duration of demonstration project and equipment lifespan (tCO <sub>2</sub> e)	119
10.3 Recommendations	119
<b>APPENDICES</b>	<b>120</b>
Appendix 1 - Broads Authority survey and census	122
Figure A1.1: Boat census locations	123
Boat Census - movements by vessel type	124
Figure A1.2: Boat census data	124
Boat Census - moorings	124
Figure A1.3: Map of current official moorings	125

Figure A1.4: Map showing the area of the 2021 BA mooring review.	126
<b>Appendix 2 - Norfolk Broads Direct survey</b>	<b>128</b>
<b>Appendix 3 - Estimation of demonstration vessel sub-system electrical energy demands</b>	<b>133</b>
Figure A3.1: Subsystems from a typical Broads holiday cruiser	133
Table A3.1: Physical properties of key systems for retrofit	134
Propulsion energy demand	134
Figure A3.2: Histogram of average daily fuel consumption (Note. outliers above 39l/day have been excluded).	134
Formula A3.1:	135
Ancillary energy demands	135
Figure A3.2: Schematic overview of existing hire cruiser water heating system	135
Hot water	135
Space heating	136
Table A3.2: IR space heaters	137
Cooking	137
Table A3.3: Energy (kWh) to cook a 'real' roast dinner (reproduced from FRPERC)	137
The estimated daily cold weather electrical energy demand for the demonstration vessel	138
<b>Appendix 4 - Demonstration vessel technical design details</b>	<b>139</b>
Demonstration vessel design highlights (Boat 1)	139
Principal electrical system layout	139
Figure A4.1: Schematic of principal electrical systems	140
Figure A4.2: AC distribution system and loads	140
Principal component list	141
Table A4.1: Principal component list for proposed demonstration vessel retrofit (Boat 1)	141
Figure A4.3: Layout of powertrain DC components	142
3D impressions of proposed retrofit design	142

Figure A4.4: Plan view of retrofit vessel with powertrain components	142
Figure A4.5: Powertrain layout within retrofit vessel and enclosing superstructure	143
Boat 2 design approach	144
Figure A4.3 'Boat 2' powertrain electrical schematic	144
Boat 2 principal component list	145
Table A4.2: Principal component list for secondary solution to demonstration vessel (Boat 2)	145
<b>Appendix 5 - The electricity distribution network serving the Broads</b>	<b>146</b>
The electricity distribution network serving the Broads	146
Figure A5.1: The Broads segmented for analysis	146
Electricity distribution cables	147
Table A5.1: Summary of notable electricity network cables	147
Figure A5.2: The electricity network across the Broads	148
Electricity network constraints	150
Figure A5.3: 132kV substations within two miles of the Broads, with indicative headroom (MW)	150
Table A5.2: Summary of notable electricity substations at 33kV	151
Figure A5.4: 33kV substations and headroom estimates	153
Alternatives to grid-connected charge points considered for future demonstration	155
Off-grid renewables	155
Figure A5.5: Boatyard solar augmented dual purpose EV/MEV charging station	155
Table A5.3: Range of dual purpose charging stations offered by Freqcon.	156
Table A5.4: Indicative statistics for a renewable energy solution powering ECPs	156
Figure A5.6: Solar canopy and static battery offering a renewable energy solution to ECP electricity supply.	157
Charging barges	157
Land-based fuel cells	157
Fuel cell electric boats	158

Figure A5.7 Design for a hydrogen fuel cell powered main propulsion system (inset Hydrogen Power Module)	158
<b>Appendix 6 - Use cases for charging infrastructure equipment</b>	<b>160</b>
Table A6.1: Shoreside charging solutions matrix	160
Use case 1 - 22kW AC charger	161
Use case 2 - 7kW AC Chargers	161
Charger Locations	161
<b>Appendix 7 - Broads moorings ECP analysis &amp; Proposed locations</b>	<b>164</b>
Table A7.1: Proposed locations for 22kW and 7kW chargers in the demonstration network	164
Specification for the Broads boat charging network	164
Methodology selecting locations for charging points	165
Table A7.2: Lengths of river sections in the Broads.	166
Assumptions and considerations in the assessment	167
Assessment	168
Figure A7.1: Broads Authority managed locations with 3 phase power supply.	168
Safety considerations – Breydon and lower reaches of the Yare and Waveney.	169
Power Supply	169
Table A7.3: Data on moorings in the region of Breydon Water	169
Figure A7.2: Potential Charging sites around Breydon water.	170
River Yare, Chet & Wensum	170
Figure A7.3: Hook-up points on the river Yare.	171
Proposed Charger Locations	172
Figure A7.4: Proposed charger locations between Norwich and Reedham.	172
Power supply	172
Table A7.4: Data on moorings on the Yare, Chet and Wensum	173
River Waveney	173

Figure A7.5: River Waveney hook-up points.	174
Considerations	174
Figure A7.6: River Waveney showing a potential charging location at Beccles.	175
Power Supply & Land Ownership	175
Lower Bure	175
Figure A7.7: Existing electric points on the Lower Bure.	176
Considerations	176
Figure A7.8: Lower Bure from Thurne Mouth (top left) to Great Yarmouth.	177
Power Supply & Land Ownership	177
Table A7.5: Data on moorings on the Lower Bure	177
River Thurne	178
Figure A7.9: Map of navigable routes upstream of Potter Heigham Bridge.	178
Figure A7.10: Upper Thurne from Thurne mouth junction.	179
Power Supply & Land Ownership	179
Table A7.6: Data on moorings on the Thurne	180
River Ant and Upper Bure	180
Figure A7.10: Map of boatyards in the Ant and Bure.	181
Figure A7.11: Speed Limits on the Northern Broads.	182
Power supply & Land Ownership	183
Table A7.7: Data on moorings on the Bure	184
Upper Ant	184
Figure A7.13: Potential Charging locations on the upper Ant.	185
Mooring management issues	185
Full list of locations assessed in the Broads	186
Table A7.8: Data held on moorings in the Broads	186
<b>Appendix 8 - Costed components list</b>	<b>198</b>

Table A8.1: Breakdown of costs for proposed demonstration	198
Table A8.2: Further Breakdown of Drivetrain and Power Distribution Costs included in Table A8.1	204
<b>Appendix 9 - User experience, social and economic impacts evaluation</b>	<b>205</b>
User experience	205
Re-fuelling and recharging	206
Heating	206
Cooking	206
Handling and performance	207
Perception of safety	207
Economic	207
Cost of boat ownership	207
Cost of hire	207
Social Impacts	208
<b>Appendix 10: Demonstration delivery timescales</b>	<b>209</b>
Table A10:1 Scope of work for proposed demonstration	209
<b>Appendix 11 - Applied examples of maritime decarbonisation</b>	<b>213</b>
Electrifying Amsterdam's Canals	213
Decarbonising vessels on the Seine	214
Norway's National Action Plan	214
Plymouth MeLL Clean Maritime Demonstration Competition (CMDC) Project	214

## Glossary

Word / phrase	Definition
AC	Alternating current
AINA	Association of Inland Navigation Authorities
Beam	Vessel width at its widest point
BEIS	The Government department for Business, Energy and Industrial Strategy
BEV	Battery Electric Vehicle
BHBF	Broads Hire Boat Federation
BMF	British Marine Federation
CCC	Committee on Climate Change
CO	Carbon Monoxide
CO <sub>2</sub>	Carbon Dioxide
CO <sub>2</sub> e	Carbon Dioxide equivalent - used as the base measure of Global Warming Potential
DC	Direct current
DER	Distributed Energy Resource - could include energy generation or storage equipment
DfT	Department for Transport
Drivetrain	The group of components of a motor vehicle/vessel that deliver power to drive the wheels/propellor. Usually defined from the engine onwards. (cf. Powertrain)
ECP	Electrical Charging Pillar
EV	Electric Vehicle
EVCE	Electric Vehicle Charging Equipment
Fast charger	Usually refers to EV charging equipment supplying 7kW or 22kW AC via one of three connector types
GHG	Greenhouse Gases
Grid	Given as shorthand for the local electricity distribution network
GVA	Gross Value Added
GWP	Global Warming Potential - the multiple of heat absorbed by any gas in the atmosphere compared to the same mass of CO <sub>2</sub>
HC	Hydrocarbons
'Hook-up'	A 16 amp or 32 amp single phase electrical connection at a mooring that supports low power electrical demands and is normally used by diesel vessels to recharge lead-acid batteries and run ancillary electrical appliances overnight.
HPM	Hydrogen Power Module
ICE	Internal Combustion Engine
IMO	International Maritime Organisation
Inland waterways	Defined as "any area of water not categorised as 'sea' - e.g., canals, tidal and non-tidal rivers, lakes, and some estuarial waters"
Li-ion	Lithium-ion
Maritime sector	While maritime refers to coastal or sea-based activity, for the purposes of defining sectors, activities that take place on inland waterways are also included under the maritime rubric
MCA	Maritime and Coastguard Agency

MEV	Marine Electric Vehicle (may include Hydrogen fuelled vehicles that depend on conversion to electricity through a fuel cell)
MEV2G	Marine Electric Vehicle to Grid (involves bi-directional electrical energy exchange)
MVI	Minimum Viable Infrastructure
NOx	Nitrous Oxides
NRMM	Non road mobile machinery
PM	Particulate Matter
PN	Particle Number
Powertrain	The system of components that deliver power to propel a vehicle, extending from the battery bank to through to the wheels/propeller
Rapid charger	Usually refers to EV charging equipment supplying 43kW AC via one connector type or 50kW DC via one of two connector types.
RET	Renewable Energy Technology eg. a distributed system providing generation, energy storage or demand response - see also 'Ultra-rapid charger' below.
RTFO	Renewable Transport Fuel Obligation
T&D	Electricity Transmission and Distribution
Ultra-rapid charger	Usually refers to EV charging equipment supplying power at 100kW DC or more (often at 100kW, 150kW or 350kW) via one of two connector types.
V2B	Vehicle-to-Building
V2G	Vehicle-to-Grid
V2L	Vehicle-to-Load

## EV charging connector types<sup>1</sup>

### Rapid chargers



### Fast chargers



<sup>1</sup>Images courtesy Zap Maps. <https://www.zap-map.com/charge-points/connectors-speeds/>

## 1. PUBLIC EXECUTIVE SUMMARY

Electrifying the Broads (Project number 10008242) is a feasibility study funded under Strand 1 of the Clean Maritime Demonstration Competition (2021-22). Four organisations led by RenEnergy, including the Broads Authority, Norfolk Broads Direct and Hydrogen East, partnered to carry out this whole systems study with the aim of specifying a demonstrable pathway to decarbonising inland waterways hire cruisers on the Broads. Broads hire cruisers were chosen as a target sector because they represent a significant contributor to the local economy, and are representative of other heavily-used inland waterways recreational vessels making a relatively high contribution to greenhouse gas emissions compared to other inland waterways vessels. The Broads offers an ideal context in which to test and measure assumptions, from which valuable high resolution performance and user data will be acquired to form the basis of future designs for the electrification of inland waterways craft.

### Objectives

Our objectives were to gather geospatial, technological and socio-economic data, to lay the foundations for a demonstration that would help to resolve the challenge of converting an existing fleet to clean energy by electrification. We aimed to resolve a trilemma concerning provision of sufficient onboard electrical energy, sufficient shoreside charging infrastructure to support battery recharging against the costs and benefits for scaling the solutions. Based on our feasibility study, we have concluded that it should be possible to operate a fully electric hire cruiser on the Broads, provided adequate shoreside infrastructure is in place. We recommend proving this with the proposed demonstration project.

### Detailed and costed demonstration plan

Retrofitting a diesel-powered hire vessel was considered the most practical approach to demonstrate technical solutions that will influence other inland waterway vessel conversion. We decided against a hybrid solution, which could not achieve full emissions reduction. Our findings reflect our proposed demonstration to test a new powertrain driven by two commercially available EV batteries on a converted 14m President class hire vessel and supported by 11 shoreside chargers (ten 7 kW and one 22 kW), whose locations were selected by analysis of typical travel distances and the availability of capacity in the local electricity distribution system. We will instrument this and an unconverted 'control' vessel to acquire operational data in order to test our technical solutions and refine designs going forward – potentially, in future, leading to a demonstration of five electrified vessels which we have described as 'Phase 2 Plus'. In addition, we will survey customers who operate the vessel for 'user experience' on holidays from April to November 2023. The results of collecting and analysing operational data will then be delivered in a final report by the end of March 2024.

### Compliance with regulation

The proposed demonstration will take place within a highly regulated environment ranging across standards for marine safety and compliance, planning authority requirements as well as the

electricity distribution network. Full details of the various requirements are specified within this report. As our partner organisations are already familiar and operating within this framework, we do not anticipate any compliance issues; however, we highlight the potential for delays in fulfilling regulatory processes which are critical for launching the demonstration at the start of the 2023 hire season.

### Lifecycle emissions savings

Our findings from the study of lifecycle emissions justify our choice of retrofitting a hire cruiser. Holiday hire cruisers make up 9% of the Broads mechanised fleet, yet the impact from converting them to clean energy would be equivalent to 18% of estimated annual emissions in 2021. This represents a saving of between 13 and 16 kgCO<sub>2</sub>e/day. Even taking a lifecycle approach to deriving these values realises a 42% to 54% improvement in emissions over fossil fuelled vessels which will improve as clean technologies mature and fossil fuel technologies decline. Under our projections, the potential from decarbonising the full fleet of some 8,000 vessels on the Broads could be as much as 5.2 ktCO<sub>2</sub>e/year by 2025, rising to 115 ktCO<sub>2</sub>e by the year 2050.

### Economic impacts

We found that marine tourism on the Broads directly contributes around £18 million per annum to the local economy, and in addition supports services ranging from pubs and restaurants to highly skilled jobs in boat building and maintenance. The Gross Value Added by electrification of hire vessels is conservatively estimated to be £213,000 per annum (once the hire cruiser fleet is fully converted), in addition to the benefits from less air and noise pollution, both significant impacts in peak summer season. Comparatively, the loss of diesel hire vessels from the Broads due to unavailability of fuel and engine parts as we enter the 2030s could have a much wider consequence for the sustainability of the local economy.

Our projections find that at least 24 new highly skilled jobs could be created in the near term if 55 vessels are retrofitted each winter with the goal of completing conversion of the hire fleet by 2035. More new job opportunities would be created in building new marine electric vessels as well as converting them if the policies were in place to drive fast adoption. A non-linear requirement to adopt MEV technologies could result in more than double this number of highly skilled jobs.

In the longer term, there is significant potential to generate additional supply chain GVA for UK companies should cost-competitive and comparable products for powertrain components and battery packs be found through UK suppliers. Given that the vast majority of retrofitting costs are associated with these components, a cumulative spend of over £72mn could occur by 2050, but based on the suppliers identified for the demonstration vessel design, the majority of this value will go to European and other international companies. This will depend on how the UK market for these components develops over the next 30 years.

### Barriers to commercial adoption

We identified and graded 10 potential barriers to commercial adoption in a Red-Amber-Green schema – including supply chain disruption, component acquisition, and the high costs currently

incurred in vessel conversion – particularly from batteries. All of these will be put to the test in the proposed demonstration. There is also the unfamiliarity of electrified vessels that currently promotes range anxiety in users, as found in electric automobiles. However, there are early signs of an interest from local boat builders in electrical solutions and support from local authorities in Norfolk with shoreside infrastructure development.

Like electrification of road transport, inland marine vessels will need a robust electrical infrastructure that can operate bidirectionally if the full value is to be gained from battery-electric technologies. In remote parts of the UK, such as the Broads, we anticipate augmentation of the electricity distribution network with renewable energy technologies, including static batteries, PV arrays and possibly river flow turbines to facilitate scale-up of MEVs. Currently we discount the possibility of utilising hydrogen fuel cells due to their cost and lack of hydrogen availability. However, as with the cost of battery systems, we believe hydrogen could play a role in clean inland waterways transport on the Broads by the 2030s.

## 2. EXECUTIVE SUMMARY

Electrifying the Broads (Project number 10008242) is a feasibility study funded under Strand 1 of the Clean Maritime Demonstration Competition (2021-22). Four organisations led by RenEnergy, including the Broads Authority, Norfolk Broads Direct and Hydrogen East, partnered to carry out this whole systems study with the aim of specifying a demonstrable pathway to decarbonising inland waterways hire cruisers on the Broads. Broads hire cruisers were chosen as a target sector because they represent a significant contributor to the local economy, and are representative of other heavily-used inland waterways recreational vessels making a relatively high contribution to greenhouse gas emissions compared to other inland waterways vessels. The Broads offers an ideal context in which to test and measure assumptions in the proposed Phase 2 demonstration, from which valuable high resolution performance and user data will be acquired to form the basis of future designs for the electrification of inland waterways craft.

### Objectives

Our objectives were to gather geospatial, technological and socio-economic data, to lay the foundations for a demonstration that would help to resolve the challenge of converting an existing fleet to clean energy by electrification. We aimed to resolve a trilemma concerning provision of sufficient onboard electrical energy, sufficient shoreside charging infrastructure to support battery recharging against the costs and benefits for scaling the solutions. Based on our feasibility study, we have concluded that it should be possible to operate a fully electric hire cruiser on the Broads, provided adequate shoreside infrastructure is in place. We recommend proving this with the proposed demonstration project.

### Detailed and costed demonstration plan

Retrofitting a diesel-powered hire vessel was considered the most practical approach to demonstrate technical solutions that will influence other inland waterway vessel conversion. We decided against a hybrid solution, which could not achieve full emissions reduction. Our findings reflect our proposed demonstration to test a new powertrain driven by two commercially available EV batteries on a converted 14m President class hire vessel and supported by 11 shoreside chargers (ten 7kW and one 22kW), whose locations were selected by analysis of typical travel distances and the availability of capacity in the local electricity distribution system. We will instrument this and an unconverted 'control' vessel to acquire operational data in order to test our technical solutions and refine designs going forward – potentially, in future, leading to a demonstration of five electrified vessels which we have described as 'Phase 2 Plus'. In addition, we will survey customers who operate the vessel for 'user experience' on holidays from April to November 2023. The results of collecting and analysing operational data will then be delivered in a final report by the end of March 2024.

Our costs for the proposed demonstration are calculated to be £783,010 spread over three years from 2022-2024; however, early confirmation of the project funding is necessary to secure lead times and availability of goods and services due to the unprecedented disruption to supply chains, and the

inherent seasonality of a project based around the tourism sector. Fortunately, we are able to source much of the demonstration service requirements locally – although charging and other retrofit components are subject to global market exposure.

### Compliance with regulation

The proposed demonstration will take place within a highly regulated environment ranging across standards for marine safety and compliance, planning authority requirements as well as the electricity distribution network. Full details of the various requirements are specified within this report. As our partner organisations are already familiar and operating within this framework, we do not anticipate any compliance issues; however, we highlight the potential for delays in fulfilling regulatory processes which are critical for launching the demonstration at the start of the 2023 hire season.

### Lifecycle emissions savings

Our findings from the study of lifecycle emissions justify our choice of retrofitting a hire cruiser. Holiday hire cruisers make up 9% of the Broads mechanised fleet, yet the impact from converting them to clean energy would be equivalent to 18% of estimated annual emissions in 2021. This represents a saving of between 13 and 16 kgCO<sub>2</sub>e/day. Even taking a lifecycle approach to deriving these values realises a 42% to 54% improvement in emissions over fossil fuelled vessels which will improve as clean technologies mature and fossil fuel technologies decline. Under our projections, the potential from decarbonising the full fleet of some 8,000 vessels on the Broads could be as much as 5.2 ktCO<sub>2</sub>e/year by 2025, rising to total avoided emissions of 115 ktCO<sub>2</sub>e by the year 2050.

### Economic impacts

We found that marine tourism on the Broads directly contributes around £18 million per annum to the local economy, and supports services ranging from pubs and restaurants to highly skilled jobs in boat building and maintenance. The Gross Value Added by electrification of hire vessels is conservatively estimated to be £213,000 per annum (once the hire cruiser fleet is fully converted), in addition to the benefits from less air and noise pollution, both significant impacts in peak summer season. Comparatively, the loss of diesel hire vessels from the Broads due to unavailability of fuel and engine parts as we enter the 2030s could have a much wider consequence for the sustainability of the local economy.

Our projections find that at least 24 new highly skilled jobs could be created in the near term if 55 vessels are retrofitted each winter with the goal of completing conversion of the hire fleet by 2035. More new job opportunities would be created in building new marine electric vessels as well as converting them if the policies were in place to drive fast adoption. A non-linear requirement to adopt MEV technologies could result in more than double this number of highly skilled jobs.

In the longer term, there is significant potential to generate additional supply chain GVA for UK companies should cost-competitive and comparable products for powertrain components and battery packs be found through UK suppliers. Given that the vast majority of retrofitting costs are associated with these components, a cumulative spend of over £72mn could occur by 2050, but

based on the suppliers identified for the demonstration vessel design, the majority of this value will go to European and other international companies.

### Barriers to commercial adoption

We identified and graded 10 potential barriers to commercial adoption in a Red-Amber-Green schema – including supply chain disruption, component acquisition, and the high costs currently incurred in vessel conversion – particularly from batteries. All of these will be put to the test in the proposed demonstration. There is also the unfamiliarity of electrified vessels that currently promotes range anxiety in users, as found in electric automobiles. However, there are early signs of an interest from local boat builders in electrical solutions and support from local authorities in Norfolk with shoreside infrastructure development.

Like electrification of road transport, inland marine vessels will need a robust electrical infrastructure that can operate bidirectionally if the full value is to be gained from battery-electric technologies. In remote parts of the UK, such as the Broads, we anticipate augmentation of the electricity distribution network with renewable energy technologies, including static batteries, PV arrays and possibly river flow turbines to facilitate scale-up of MEVs. Currently we discount the possibility of utilising hydrogen fuel cells due to their cost and lack of hydrogen availability. However, as with the cost of battery systems, we believe hydrogen could play a role in clean inland waterways transport on the Broads by the 2030s.

## 3. INTRODUCTION

### 3.1 Background to the Broads

The Broads is the term used to describe the wetland system of 60 open water areas connected by a network of seven rivers, over 303sq.km. It is an iconic part of the landscape in Norfolk and Suffolk and is a nationally significant tourist destination as well as an important source of revenue. As this study will seek to illustrate, it offers an ideal test-bed for researching and demonstrating solutions to decarbonise vessels on inland waterways.

The Norfolk & Suffolk Broads (or, “The Broads”) is a man-made environment, formed from mediaeval peat diggings and then developed over the centuries for navigation - firstly for transporting goods and, since the mid-19th century, as a unique holiday destination.

Early visitors to the Broads typically arrived by rail and enjoyed skippered charter aboard sailing boats such as Norfolk wherries, before self-skippered holidays were introduced aboard sailing cruisers and, from the 1930s, motor boats. By the 1960s, the Broads was one of Britain’s most popular holiday destinations and, at its peak, there were 2,500 motor cruisers for hire across the 200km of navigable waterways - with visitors typically spending 1 or 2 weeks aboard and exploring most of the network.

As international travel became popular and affordable, many people chose to take their main family holiday overseas - but changes in working patterns allowed domestic tourism to take advantage of a new short-break or ‘staycation’ market. As a result, a typical Broads holiday may now be 7 nights or fewer.

Today, there are around 730 motor cruisers available for hire, and the number of private boats has increased and is now over 7,000. Many of these private vessels were formerly hire vessels, and it is not uncommon to see boats from the 1960s and earlier still in frequent use. As hire operators gradually develop methods of reducing the carbon footprint of their vessels, we can expect that technology to ripple out amongst private boat owners as well.

The Broads has a similar status to a National Park under the Norfolk & Suffolk Broads Act 1988, and is managed by the Broads Authority, with powers similar to other National Park authorities. As well as being charged with the protection of the natural landscape and local cultural heritage, the Broads Authority is also the local planning authority and navigation authority for the waterways.



### 3.2 Importance of the proposed project and demonstration

According to data from the Canal and Rivers Trust (see Table 7.1) about 0.2% of vessels licensed by them are claiming electric boat discount. In the Broads, hybrid vessels can claim the electric discount if they have an electric drive powered by a diesel generator & battery; there are hire cruisers that claim the electric discount, but there are no fully electric cruisers on the Broads. As a nationally significant tourist destination, the Broads welcomed 8.18million visitors in 2019, contributing £665 million per annum to the local economy. Underpinning the local economy is the central attraction of inland waterway boating holidays for tourists visiting the area. This important contribution would be threatened without support to reach net zero by 2050 under the inclusion of marine carbon emissions within the 6th Carbon Budget. To protect the natural environment, the Broads Authority,

as the Navigation Authority, has also set an aspiration of reducing carbon emissions from energy use by approximately 80% by 2030, from 2018 levels<sup>2</sup>.

### 3.3 How this project fits with a clean maritime future

To date, electric motors have only been deployed on the Broads in a few small outboard vessels, day boats, and sailing yachts. The cruiser fleet is almost entirely fossil fuel powered, and there is not a market-ready solution for vessels that spend weeks away from their base. These vessels release an estimated 5.2 ktCO<sub>2</sub>e emissions each year<sup>3</sup>, with the added risk of environmentally toxic fuel spills, and air pollution from running engines to provide domestic power whilst moored. Progress towards electrifying day-hire launches is ongoing, and attention now needs to turn to larger holiday cruiser vessels which do not rely on a daily 'back-to-base' recharging model. Part of the challenge in finding solutions to inland vessel decarbonisation lies in the relatively long life of a vessel hull (40 years or longer) compared to its on-board systems. For this reason we investigate retrofitting existing vessels, as opposed to the more costly new build – or substitution – approach.

At present there is also no existing model of a decarbonised boating network we can apply to inland waterways. Decarbonisation will require the alignment of physical charging infrastructure, design of retrofit propulsion and ancillary systems and policies to incentivise the take-up of zero-emission boats. If these elements do not align, the technology will not be adopted, therefore a partnership of private and public bodies is needed to establish feasibility options.

This is not a straightforward transition simply requiring the substitution of diesel engines – currently the dominant propulsion technology – by a clean energy technology. It will require a systematic approach, reflecting the needs to decarbonise and protect natural capital as well as to deploy new and innovative systems to support boating activities, whilst continuing to maintain the local economy. We will therefore also address the requirements for appropriate and supportive infrastructure to satisfy the estimated energy demand of retrofitted and new-build options for boat operators to decarbonise their fleets. The target for the purpose of this feasibility study will be identified as a 'typical holiday cruising vessel' which provides the mainstay of the tourist economy within the geography of the Broads.

Beyond that, the social tradition of diesel-powered boating will also be considered to better understand the measures and inducements that could be required to stimulate the clean energy transition within local boat builders as well as its possible impact upon the local economy, skills and training requirements. In this way we aim to contribute to the policy and regulatory landscape in support of reaching Net Zero 2050 within this sector.

The needs case for the project includes targeted action to account for:

---

<sup>2</sup> Broads Climate Change Action Plan, page 6

[https://www.broads-authority.gov.uk/\\_data/assets/pdf\\_file/0022/330088/Climate\\_Change\\_action\\_plan-ba240720.pdf](https://www.broads-authority.gov.uk/_data/assets/pdf_file/0022/330088/Climate_Change_action_plan-ba240720.pdf)

<sup>3</sup> Based on 2021 fuel receipts (see Table 7.17)

- The dependency of the local economy on attracting tourism through the use of the Broads for boating holidays, with the biodiverse ecosystem one of the primary draws.
- The need to safeguard existing jobs and create new ones in boatyards to ensure that the benefits from a transition to zero-carbon propulsion are felt locally.
- The dependency of leisure cruisers upon derivations of motor vehicle diesel engines which will cease to be available by 2035.
- The likely reduction in the availability of diesel and similar fuels over the course of the next two decades.
- The need for maritime emissions to respond to national standards and, in any event, reach net zero by 2050.

The challenges which have inhibited action in this area to date include:

- The cost of retrofitting zero-emission propulsion solutions to a range of vessels with differing hull designs, some of which are many decades old.
- The reliance of other onboard systems on diesel-powered propulsion systems such as for heating and hot water. Other on-board systems are also reliant on fossil fuels, such as for cooking.
- The use of domestic level electric current to support lighting and ancillary systems for navigation and audio visual entertainment.
- The current lack of shore-side infrastructure to support the energy needs of clean propulsion systems. Rolling out a suitable charging network has a high cost, with even the simplest locations immediately adjacent to an existing Low Voltage (less than 1kV) power cable, with no need to install additional cables, costing in excess of £18,000 to connect to the grid. Therefore creative off-grid solutions, or additional revenue, is needed to offset this cost.
- Competition for limited mooring facilities where electric hookup facilities are currently located.
- Moorings tend to be in private ownership. Access to sufficient land-based charging locations will therefore require agreement with multiple stakeholders.
- Standards - hire boat operators will need to ensure compatibility as well as interoperability of fleets and charging facilities.
- Finding the right balance of actions to incentivise the leisure boating community to transition to alternative propulsion, given that diesel engines in this location and vessel class have long working lives and the charging infrastructure is limited at present.
- Accessing relevant data on leisure boating usage and consumer appetite for change.

The *Electrifying The Broads* (ETB) project, aims to path-find ways for marine decarbonisation using the context of the Norfolk Broads for the feasibility study. A consortium of stakeholder partners has recognised this need, based on the inevitability that future, mandated marine decarbonisation will encompass inland waterways and thus impact upon the nature of this core business activity within the Broads area of Norfolk & Suffolk, as well as further afield.

In Strand 1, ETB investigates ways to decarbonise propulsion of holiday hire cruising vessels, including the need for recharging infrastructure. Our costed plan arising from this analysis leads to a proposal for a demonstration of solutions in Strand 2, with the aim that findings would support further scaling and include a wider range of Broads vessels. These could also be applied in other

inland waterways contexts. We believe the framework of proposals we have developed in Strand 1 should inform inland waterways with similar leisure fleets, including the Thames, Lake District and canals.

## 4. OBJECTIVES OF THIS FEASIBILITY STUDY

The objectives for this feasibility study can be expressed in resolving the three-fold challenge summarised in Figure 4.1 below. We are laying the groundwork to demonstrate a pathway to vessel electrification that itself needs to form a balance between marine and shoreside technical solutions with an acceptable cost-benefit ratio from undertaking the initiative. At the same time, we recognise the proposed demonstration is only the first step in realising the destination of electrifying the Broads and, more widely, addressing the needs of an inland waterways clean maritime vision.

Figure 4.1: The ETB challenges represented as a trilemma

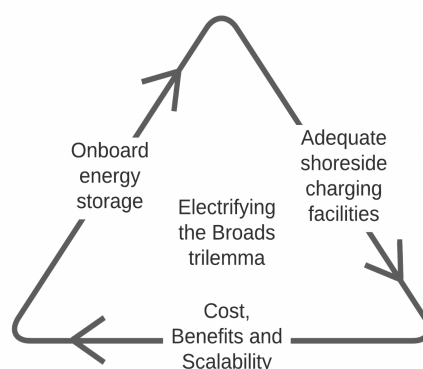

Table 4.1 below, outlines our feasibility study (Strand 1) objectives against criteria for their achievement and how we overcame barriers to their success.

Table 4.1: Outline of objectives in the ETB feasibility study		
Objective	Criteria for success	Barriers overcome
Identify needs case for demonstration in context of local economy and decarbonisation.	Surveys of Broads users and decarbonisation policy context set out justifications for doing the proposed demonstration.	Drawing together a variety of socio-economic and regulatory information to make the case.
Identify vessels for electrification and control, from NBD operational records.	Demonstration and control vessels identified.	Lack of data on specific system energy demands to specify retrofit vessel.
Identify systems for electrical conversion.	Integrated design for replacement systems. Identify suitable suppliers and partners to join in implementing proposed demonstration.	Unconventional voltage level combinations required novel electrical design. Multiple equipment suppliers engaged in this design challenge.
Identify moorings to receive new ECPs with respect to local electricity network capacity.	Analysis of Broads waterways network identifying mooring locations for ECP installation.	Lack of data on vessel movements under hire. Lack of publicly available information on

		electricity network capacity to support connection of ECPs.
Design and costing of proposed Strand 2 demonstration.	Costs and delivery schedule for proposed demonstration project.	Equipment inventory, costings and plans for executing demonstration were only possible after designs for retrofit were confirmed.
Develop business case for demonstration.	Describe a business case based on multiple criteria, including cost, economic impacts, environmental and social impacts.	Lack of local socio-economic data required extrapolation from relevant tourist information.
Survey of maritime and transport regulatory landscape with respect to inland waterways decarbonisation policies.	Set context for proposed demonstration within relevant regulatory landscape and permissions.	Vast range of policies, regulations and permissions required processing to identify pertinent framework for the proposed demonstration.
Estimate lifecycle emissions savings from proposed demonstration and at scale from wider MEV wider adoption on the Broads.	Describe functional unit, per unit emissions savings and at scale emissions savings.	Baselines were constructed by estimation from available evidence.
Set out perceived risks for demonstration and barriers to commercial adoption (Chapter 9).	Comprehensive demonstration risk assessment (accompanying document); identification of various degrees of barrier to MEV technology diffusion and commercial adoption.	Unknowns due to the novelty of the project were addressed with due prudence by local experts engaged in management and hire sectors on the Broads .

We also intended to explore a highly innovative work stream which would seek to de-risk investment in electrification of marine propulsion systems and charging infrastructure to avoid stranded assets in low season periods. This involved estimates of the technical and economic benefits from implementing MEV-to-grid (MEV2G) energy transfers through the use of a bidirectional electric charging pillar (ECP). We are unaware of anyone exploring these opportunities to date and believe they have important learning outcomes for all fleets that see strong seasonal variation in use. However, the scale of the proposed demonstration and the current cost of a bidirectional charger meant that we do not recommend this in Strand 2 as the investment for servicing one electrified vessel in one boatyard would be uneconomical and not yield the full impact from operating a number of electrified vessels. However, when MEV technology diffusion scales up, this implementation should be demonstrated as an integral part of the shoreside charging network. We were also informed by UK Power Networks (UKPN) that the opportunities for installations of bidirectional chargers in the Broads region were very limited at present due to the weak electricity network capacity. This points to initially installing them at major boatyards where a number of MEVs are likely to be moored over the winter season.

## 5. PLAN FOR A FUTURE DEMONSTRATION PROJECT

In this chapter, we produce a clear, detailed and costed plan for how the solution will be demonstrated in an operational setting, including its technical approach, its objectives and business case.

### 5.1 Description of demonstration project

Hire boats typically do the highest mileage of all the boats on the Broads, as operators aim to maximise usage throughout the hire season, normally extending from Easter to late Autumn. Holiday hire cruisers have been chosen as the focus of the proposed demonstration for a number of reasons, including:

- Their relatively high contribution as a sector to Broads carbon emissions.
- Their ownership is concentrated in a small number of operators.
- The usage patterns of the various types of hire vessel are more predictable.
- Many of the private vessels that are based on the Broads and regularly navigate the area are former hire vessels and therefore share characteristics.

By studying a typical example of a holiday hire cruiser and its usage, the demonstration will be able to inform conclusions about the feasibility of electrifying a much wider boating population as well as to confirm assumptions about the supporting energy infrastructure needed.

Because of the pathfinding nature of the ETB project, the proposed future demonstration project aims to develop knowledge and understanding that will support progress on the Broads towards the national objective of decarbonising marine emissions on inland waterways. It also addresses, in terms of the local economy which depends on tourism engaged in boating on the Broads, the imperative that ways are found to facilitate a transition of existing craft to clean energy, and to promote adoption of new MEV vessels and clean energy technologies as they become available and affordable. In the next ten years, if the shoreside hydrogen economy develops, this could include the use of hydrogen fuel cells as well as battery technologies.<sup>4</sup> However, for now we focus on vessel electrification which will be a no-regrets investment whether the ultimate energy source is from batteries or fuel cells – as both will provide electricity to onboard systems.

The proposed demonstration project as a result of this feasibility study will be composed of the following main elements:

- Retrofit a demonstration vessel from one of the least efficient and most heavily used craft in the hire fleet to demonstrate electric systems of propulsion and onboard services.
- Implement sufficient shoreside charging facilities to support the use of the demonstration vessel on the Broads and for recharging at its base.
- Collect and analyse data on energy demand from sensors installed on the demonstration vessels, and boating patterns. Evaluate user experiences to help direct future work. Compare findings with an unconverted 'control vessel'.

---

<sup>4</sup> <https://genevos.com>

- Work with key partners identified in the feasibility study to deliver the demonstration and support the ongoing transition to MEVs beyond the demonstration.
- Trial the use of energy saving devices such as recirculating showers, IR heaters and instant hot water taps to reduce the amount of power needed and therefore the minimum size of battery needed for future conversions.

### High level demonstration timeline

Figure 5.1 below, summarises the anticipated timeline and the key stages in carrying out the proposed demonstration. The detailed timeline, deliverables, stage gates and milestones are presented in 5.7, below.

**Figure 5.1: High-level demonstration timeline**

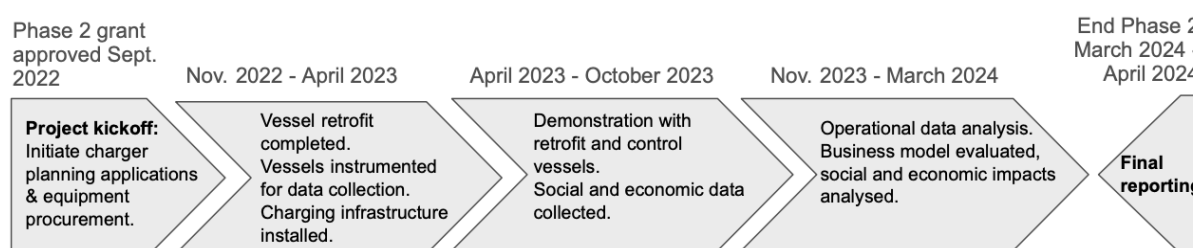

## 5.2 Objectives of the demonstration project

The overarching objective of the ETB demonstration project is to assess the viability of an electric hire cruiser and gather data to form a blueprint for a wider roll-out across the cruiser fleet. We seek to demonstrate the viability of technical, operational, economic and social solutions as follows:

- **Technical viability:** By developing a clearer understanding of the requirements and challenges of fleet conversion based on findings from the demonstration, including adequate onboard energy carried in battery banks connected to a suitable powertrain.
- **Operational viability:** By understanding what will be required to offer sufficient charging facilities, in terms of location, power and number of chargers, to meet the demands of the demonstration vessel, and apply this learning in predicting requirements for a future scale-up of MEV adoption.
- **Economic viability:** By developing a clearer understanding of the economics, costs and benefits (including to the local economy) of a rollout of MEV technologies based on the findings from the demonstration.
- **Social and environmental viability:** By understanding the impact of the demonstration vessel upon users, from their experiences and feedback, to project the wider impacts this may have on the future of the Broads hire sector and its environment.

A further objective of demonstrating bidirectional MEV charging to offer energy injections to the distribution network was considered as it could offer an attractive additional benefit to the business case through the sale of network flexibility services. However, we dropped this from the proposed

Phase 2 demonstration for reasons connected to the expense of a bidirectional charger (although the cost is likely to reduce in future) and the advice from UKPN informing us that the opportunity for flexibility services was currently limited in the remote areas where we are working.

We believe this would be a valid additional objective to demonstrate in the future when there are more electrified vessels, and bidirectional charging – or a shoreside static battery to facilitate energy exchange – make better economic sense. We refer to the potential financial benefits that could be achieved from such an intervention in Section 5.4.4, below.

### 5.3 [Technical approach](#)

The technical approach to the demonstration emerging from the feasibility study rests upon achieving the objectives outlined in 5.2. The background analyses we performed to design the approach can be found in the following Appendices:

- [Appendix 1](#) - A survey of Broads boating users conducted by the Broads Authority.
- [Appendix 2](#) - A survey of hire customer responses to Broads electrification conducted by Norfolk Broads Direct.
- [Appendix 3](#) - Analysis of energy demand data for cruiser subsystems (see also Chapter 7).
- [Appendix 4](#) - Technical design details for demonstration vessel.
- [Appendix 5](#) - The electricity distribution network serving the Broads.
- [Appendix 6](#) - Use cases for charging infrastructure equipment.
- [Appendix 7](#) - Broads moorings ECP analysis & Proposed locations
- [Appendix 8](#) - Costed components list.
- [Appendix 9](#) - User experience, social and economic impacts evaluation.

This work led to setting baselines in order to design the proposed demonstration that would test the original estimates and assumptions.

The technical detail of the approach from the feasibility study to the proposed demonstration is outlined in Figure 5.2, below. The steps undertaken within the feasibility study are identified in yellow boxes and numbered for identification purposes only, as many actions took place in parallel. The green boxes indicate where the demonstration project is planned to commence which are expanded upon in more detail in Section 5.3.1, below.

Figure 5.2: Key stages in the technical approach leading to the demonstration

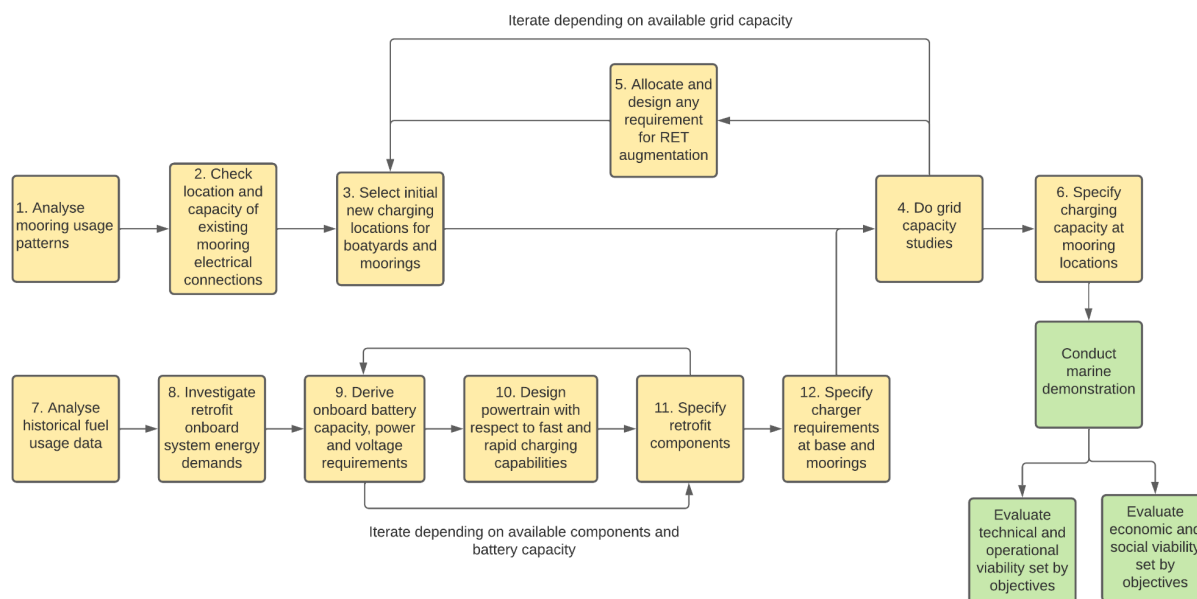

A commentary summarising the above steps follows below. More technical detail which fed into deriving energy use for emissions calculations can be found in Chapter 7:

- Waterways usage data collected by BA surveys and expert knowledge of boating patterns provided by NBD were analysed to identify which moorings are most heavily used by Broads vessels.
- The existing electrical hook-ups and charger availability at boatyards and mooring sites were assessed for capacity in the selection of sites for new charger installations, including the capacity of existing ground infrastructure.
- A shortlist of some 35 charger locations was drawn up with regard to the proximity of electrical substations at 11kV. Parent 33kV substations were also checked to estimate the upstream and downstream capacity available, to identify potential grid capacity for MEV2G energy exchange in future (See Appendix 7 for details of this study). For downstream capacity, attention was given to the energy demand that would arise from fast AC (up to 22kW) and rapid DC (up to 150kW) chargers. We were informed by UKPN that due to distortion placed on the electricity networks by rapid and ultra-rapid DC chargers, these are limited to three per 11kV substation. We then decided for the single MEV in the proposed demonstration it was sufficient to implement one 22kW AC fast charger at the NBD boatyard and a series of 7kW AC fast chargers at other moorings .

A projection of the rollout of additional chargers in a future scale-up of MEV technology adoption is given in [Appendix 6](#). However we advise caution as the number, type and capacity of chargers will be a function of the popular adoption of MEVs, their associated cost and the availability of an adequate electrical supply to connect them, as described in Section 4, above.

- The modified list of substations from the research detailed in [Appendix 5](#), which used data in the public domain, was then submitted to UKPN for 'Red Amber Green' (RAG) studies in

order to assess the potential for connection of specified charging capacity and the time it would take. The availability of existing grid connections to 100kW Internal Drainage Board (IDB) pumping stations close to remote moorings were also considered as a potential way of securing capacity for a new charger by 'piggy-backing' upon their existing grid connection. These pumps only draw power at specified times (when needed to lower local marsh drainage ditch water levels) - potentially offering a novel solution to energy demand for charging, outside of pump usage times.

5. Distributed energy resources (DERs) in the form of solar arrays, run-of-river turbines and static shoreside battery storage were also considered to provide charging capacity where the grid was unavailable to support a connection without expensive reinforcement. However, in the proposed demonstration, due to the small number of chargers and the anticipated demand upon them from a single vessel, it was deemed unnecessary at this stage to implement plans for DERs as the available local electricity capacity will be sufficient at selected moorings.
6. Locations for chargers were surveyed from the sites of electrical connections already existing at moorings. Data from BA surveys and analysis of waterways movements was included to gain a wider understanding of distances most likely to be travelled under typical cruising in order to identify the critical locations for installing MEV shoreside chargers at mooring sites. A final shortlist of sites meeting the initial energy demand anticipated for charging requirements under the demonstration project was then established (see [Appendix 7](#)). This formed part of a larger list of chargers and their locations that would need to be implemented as the number of MEVs scales up following the demonstration but is not intended for the proposed demonstration.
7. Operational fuel usage and vessel hull data for the NBD fleet of holiday hire cruisers was obtained for the 2018-2020 hire seasons and analysed to understand nominal fuel usage per cruise night (see Chapter 7 for more details) and typical fuel consumption for different cruise durations and vessel types. 2018 was used as baseline data because it avoided disruption to the hire sector caused by Covid-19 lockdowns.
8. A President class hire cruiser was selected as the demonstration vessel from our analysis of the NBD fleet based on its record of high fuel use and demand for hire (see Figure 5.3, below). We then estimated the subsystem energy demands from an investigation of its fuel usage data. Our objective was to retrofit electrical components to replace the current fossil fuel systems, including:
  - a. Main propulsion engine and bow thruster
  - b. Hot water and space heating
  - c. Cooking
  - d. Ancillary electrical systems

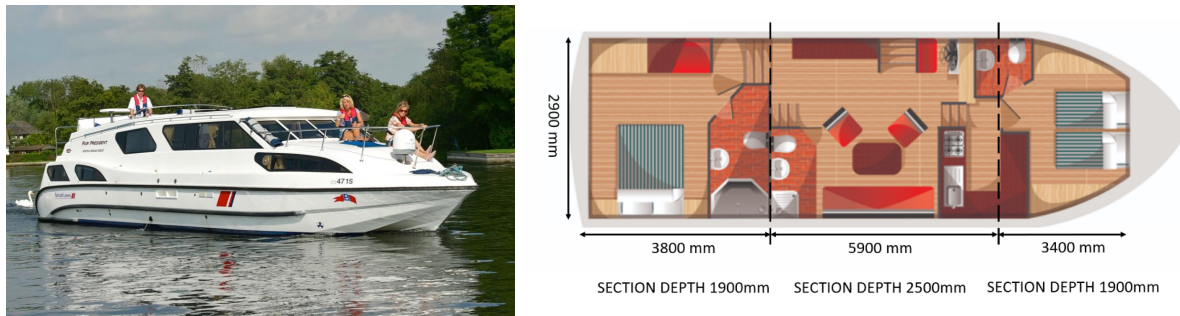

Figure 5.3: A President class hire vessel and dimensions

The analysis of subsystem energy demand is detailed in [Appendix 3](#). We arrived at a nominal cold weather daily energy demand of 60kWh but this has to be set against subsystem energy use variability in hot and cold ambient conditions and duration of cruise (in nights). In hot weather the estimated total energy demand could fall to around 40kWh. These variables are discussed in more detail in Chapter 7 when deriving emissions savings.

9. We set out with the aim of provisioning for about 2-nights worth of onboard energy, with an initial estimated energy requirement of about 100kWh. This was deemed desirable to reduce the user demand for access to ECPs, especially in future when more electrified vessels are launched and are competing for charging facilities. The tradeoff between expense and carbon footprint of large batteries was considered against the expense and feasibility of a higher population of chargers. Other considerations included the amount of time vessels were likely to access ECPs at moorings and boatyards in order to satisfy users and hire centre operational turnarounds.

We realised that the actual energy demand will depend on a number of in-service variables (see Chapter 7 for details) and a compromise had to be struck between the physical size of the battery and space to accommodate it, its energy capacity against cost and emissions footprint implications. The space issues would be designed-out of a new-build MEV, but are a consideration in a retrofit.

10. Design of the powertrain (see Figure 5.4, below) necessitated a solution that accounted for the desirability of a relatively high charging voltage to refill the battery bank in a short period of time at the boatyard (overnight at moorings is not so time-critical) but connected to a propulsion motor requiring about 15kW. In order to transfer the Power (kW) required, the conversion needs to be 400V DC to ~100V DC, giving approx 30kW power transfer across the converter. Thus a 96V, 15kW motor nominally would be suitable in this voltage range. To reduce voltage to 48V (next reasonable motor voltage), only 8kW of power transfer is possible which is not enough for propulsion and other subsystems. The DC:DC converter is an item that is 'off the shelf' but will require programming and installation from the provider to match the battery and motor voltages correctly (see [Appendix 4](#) for further details).

Two 42.2 kWh, BMWi3 batteries provide the main energy store for the Torqeedo propulsion motor. These are rated at a nominal 352V and are started by a 12V battery. The 12V battery

supplies the 12V on-board network independently of the high voltage batteries, and is necessary for powering up the system and switching on the high-voltage batteries. The main batteries are charged through onboard chargers rated up to 22kW which will enable a full charge in about 3.5 to 4 hours. Connected to a 7kW ECP, the battery bank can be fully recharged in about 12 hours, which is acceptable when moored overnight.

With MEV adoption scale-up, at base boatyards, multiple hire vessels will need to be turned around in less than 6 hours between hires and with multiple boats to turn around for service simultaneously, we require the fastest possible recharge time with respect to the aforementioned constraints in (9) above. DC Rapid chargers are likely to be required to accommodate this scenario which is beyond the scope of the proposed demonstration.

The Shore Power Distribution box allows the use of multiple charger units if required. Depending on the model, this unit ensures that the shore power connection is disconnected when the Emergency Off Switch is triggered. In addition, the 12 V battery is supported.

11. We set out to replace all on-board fossil fuel dependent systems, including cooking and heating by specifying the replacements based on iterations of the results from (9) and (10), above. See [Appendix 8](#) for a costed components list.
12. The approach described above in (7) to (11) enabled us to specify the charging capacity requirements for the proposed demonstration with built-in no-regrets implications for the initial stages of scaling-up of the number of MEVs on the Broads beyond that.

The technical approach described above required us to work with a number of suppliers and consult with other related projects in developing the required technical solution to enable the proposed demonstration. Our chosen solution came from two possible designs (called Boat 1 and Boat 2) which are detailed fully in [Appendix 4](#). We settled upon a modified Torqeedo solution (Boat 1) because of its more advanced nature in terms of component integration and the use of mature technologies from the electrified automotive and marine sectors.<sup>5</sup>

---

<sup>5</sup> <https://www.torqeedo.com/en/products/inboards>

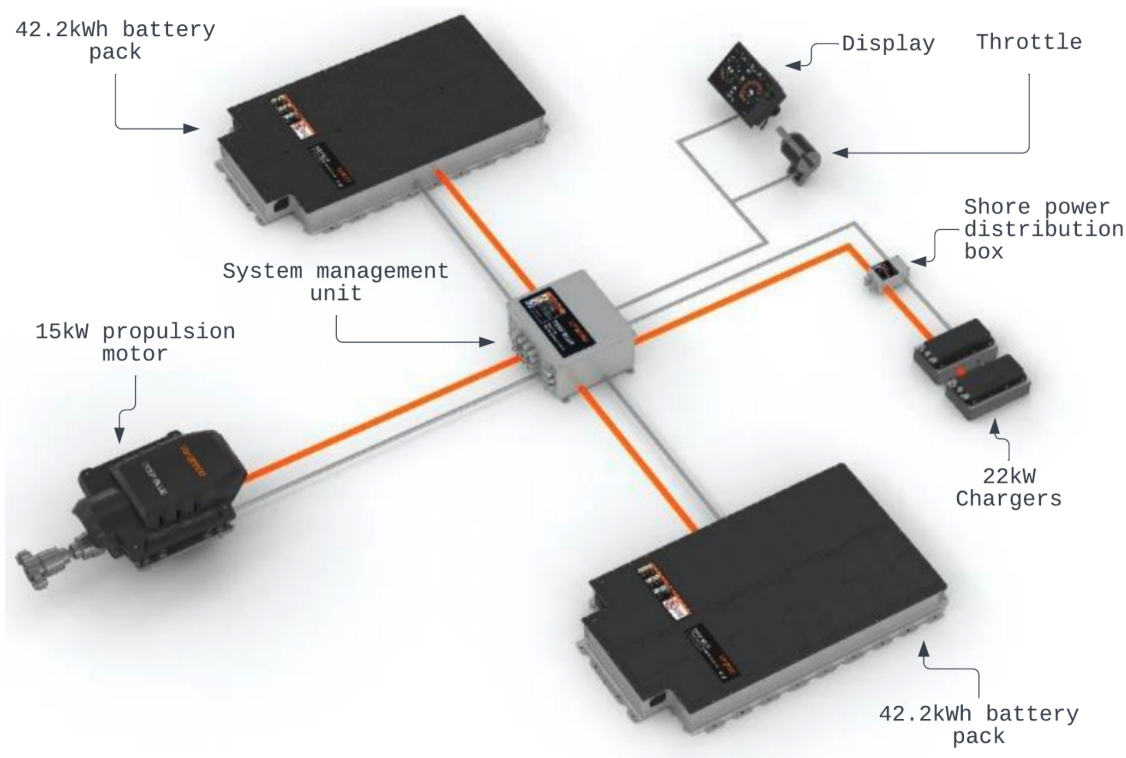
Figure 5.4: Powertrain overview<sup>6</sup>

### 5.3.1 Description of the demonstration project

Following-on from the technical approach to the demonstration described above, we now describe in detail the proposed demonstration which will be composed of three main parts.

1. Prepare technical systems on the demonstration vessel
2. Prepare specified charging infrastructure
3. Analyse operational data from technical systems and evaluate. Conduct user experience and economic impact evaluations

The proposed project will retrofit one President class inland motor cruiser to run entirely on electricity, hiring it out to customers for the duration of one tourism season (March – October), gathering data and conducting research on the retrofitting process, energy usage, customer experience and ongoing maintenance. In addition, the demonstration must deliver a Minimum Viable Infrastructure (MVI) to support the charging needs of the vessel. Operational data to a higher resolution than previously available will be collected and analysed to evaluate technical solutions, emissions savings (against a similar fossil-fuelled ‘control vessel’) and social and economic impacts.

The main parts to the proposed demonstration are highlighted and described in the following text. The pathway concerning RETs is for illustration purposes only as we are aiming to make all chargers operate solely from a grid connection. However, due to the weakness of the Broads area electricity network, RETs may feature in future in support of charging requirements. A control vessel of the

<sup>6</sup> Image courtesy Torqeedo GmbH

same type will be monitored to make critical comparisons. The key stages of the proposed demonstration are summarised in Figure 5.5, below.

It is anticipated that the President class hire vessel(s) will be lifted from the water at the NBD boatyard and work shall commence between November 2022 and April 2023 to prepare the vessel for re-entry into the 2023 hire season for the demonstration.

**Figure 5.5: Overview of key stages of ETB Phase 2 demonstration**

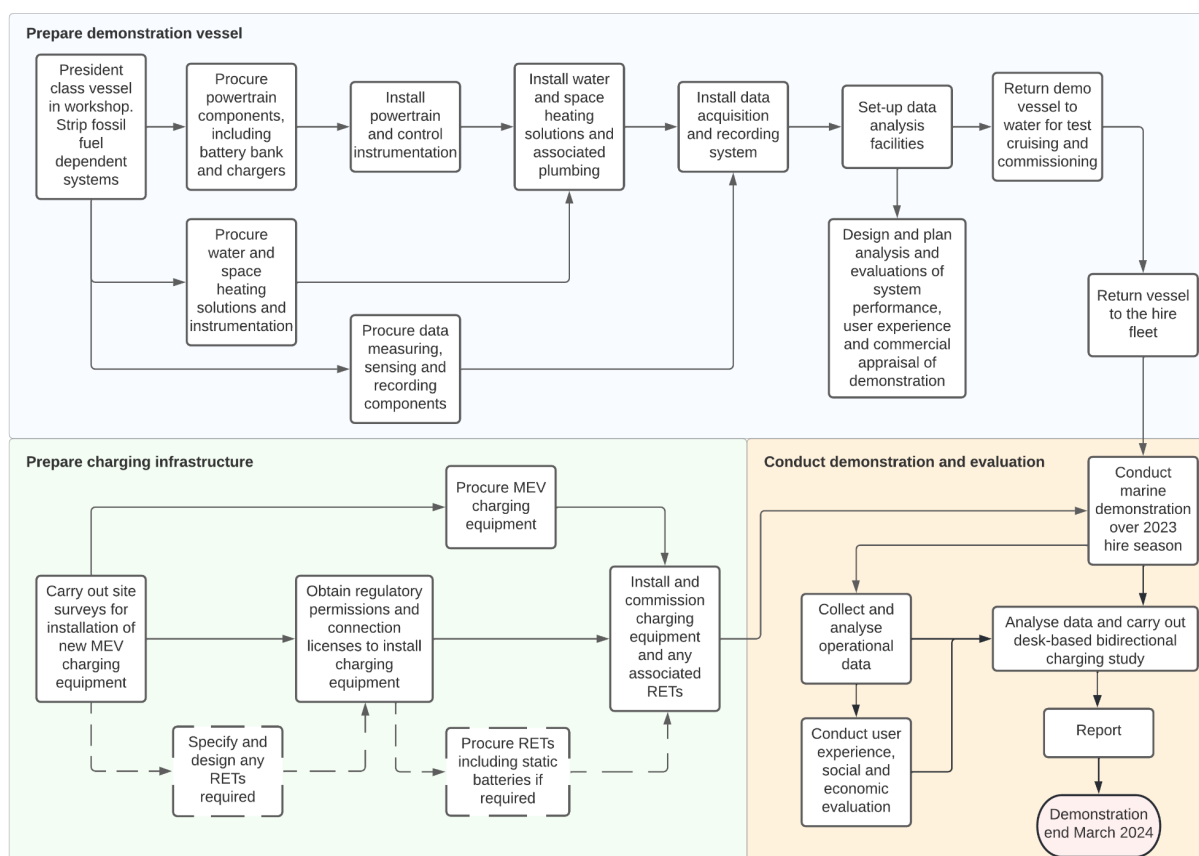

### Prepare demonstration vessel

The main elements of preparation for the demonstration vessel are outlined below.

1. Select a President class vessel after the end of the 2022 hire season and lift from the water to the boatyard for preparation in the workshop.
2. Procure all specified retrofit and measuring components,
3. Disconnect and remove fossil fuel dependent systems including:
  - a. Engine and associated electrical systems including lead acid batteries,
  - b. Fuel tank and fuel lines,
  - c. Diesel cabin heater(s),
  - d. Calorifier and pipework to engine,
  - e. Gas cooker,
  - f. Propeller, propellor shaft, hydraulic pipes and hydraulic motor,

- g. Bow thruster and associated hydraulic system,
  - h. Any non-functional control equipment.
4. Prepare locations for retrofit items, both underfloor and in the cabin. Space heaters and new controls as well as underfloor mountings and electrical charging sockets will be new features on the vessel.
  5. Retrofit electrical systems to replace the functionality of the decommissioned systems, including:
    - a. Electrical propulsion motor with compatible propeller shaft, couplings and propeller,
    - b. Electrical bow thruster,
    - c. Electrical instantaneous hot water systems,
    - d. Electrical space heating system,
    - e. 84.4kWh marinised battery bank and charging system,
    - f. Wiring and instrumentation to control all new retrofit systems,
    - g. Sensing, measuring and data logging equipment to acquire data for operational performance analysis of each new system.

### Prepare charging infrastructure

It is our intention to create 'electric corridors' for cruisers to charge-up and navigate on the Broads. The availability of an enhanced charging network will be increasingly important as MEV uptake develops. Based on the assessments in the feasibility study, we have identified two forms of charging (AC and DC) that will be required in a scalable electrified broads network, corresponding to growth in the number of MEVs. For the purpose of the demonstration we plan to only install AC chargers as this will offer sufficient infrastructure, and at the same time save on the higher cost of DC chargers.

When the demand for charging increases with the number of MEVs operating on the Broads, we also foresee the need for some of the remotest moorings to require renewable energy technologies (RETs) such as a PV solar array, coupled to a static battery to augment, or stand in for, a grid connection. We do not intend to install these in the demonstration because we can access sufficient grid capacity at this stage; however, as the project develops, it will be clearer which points on the waterways network are most in need of additional electrical support. This explains why this pathway is included in dashed lines in Figure 5.4. Instead, we will work with project partners to implement one 22kW fast AC charger at the NBD boatyard and up to eight 7kW fast AC ECPs at strategic locations.

A critical element affecting the delivery schedule of the demonstration project is in preparation of sites for any new charging and shoreside infrastructure. This is due to the often lengthy process to obtain necessary planning permissions and connection approvals. It will therefore be important to start early implementation of the selected charging sites for the demonstration to avoid delays at the start of the hire season. We plan for the key steps outlined in Figure 5.4, above, to begin at the start of the demonstration as follows:

1. Carry out site surveys to determine on-site installation features.

2. Apply for planning permissions and grid connection permits. As a local authority the Broads Authority can use permitted development rights for sites that it manages. Sites not managed by the Broads Authority will need to apply to the BA as the local planning authority for planning permission. Additional permissions to connect chargers to the electricity network will also be required from UKPN. See 5.6, below for a discussion of permits and permissions required to conduct the demonstration project.
3. Purchase the chargers for the designated sites and arrange site works contractor(s).
4. Install and commission chargers ready for operation in the demonstration.

We are proposing to install 7kW chargers at ten locations and one 22KW charger identified in Table 5.1 below for the purposes of the demonstration project. Our costs in Chapter 5.5 include the components and connection estimates from the study we commissioned UKPN to carry out.

<b>Table 5.1: Locations of chargers in the proposed demonstration project</b>					
Serial number	Name/Location	Co-ordinates <sup>7</sup>		Charger Capacity (AC kW)	Existing ground infrastructure
		Easting	Northing		
1	Norfolk Broads Direct Boatyard	630230.5	317953.5	22	3 Phase 100 Amps
2	Berney Arms	646790.5	305197.4	7	None
3	Great Yarmouth Yacht Station	652052.9	308677.6	7	3 Phase 100 Amps
4	Norwich Yacht Station	623839.7	308508.9	7	3 Phase 100 Amps
5	Beccles Yacht Station	642185.1	291217.9	7	3 Phase 100 Amps
6	Reedham Yacht Station	642131	301805.1	7	1 Phase 60 Amps
7	Ranworth Staithe	652052.9	308677.6	7	1 Phase 100 Amps x2 - serving separate "spurs" of the mooring
8	Potter Heigham	641941.7	318384.1	7	1 Phase 100 Amps
9	Acle Bridge	641361.6	311731.8	7	3 Phase 100 Amps
10	Upper Ant	TBD	TBD	7	Depending on 3rd party agreements, BA site has 1 Phase 100 Amps

<sup>7</sup> Coordinates are given using the Ordnance Survey National Grid. These can be searched using <https://gridreferencefinder.com/>

11	St Bennets Abbey	637592.5	315995.6	7	None
----	------------------	----------	----------	---	------

Details on the grid studies and mapping analysis leading to the selection of sites for chargers can be found in Appendices 5 and 7. Details of the use cases considered for chargers and their technical characteristics are presented in [Appendix 6](#).

### Conduct demonstration and evaluation

The proposed demonstration will run during the 2023 hire season, from spring until late autumn (usually April to October). It will be aimed at collecting and analysing data collected from a retrofitted and a control vessel as well as user experience surveys (see Figure 5.5 above). From this we aim to further the understanding of operational energy demands, potential for bidirectional energy flows and user experience, and to gain insights into the potential impacts of a clean marine economy. By gathering this essential information the demonstration should also enable more accurate targeting of measures to electrify the Broads and other inland waterways going forwards.

#### *Data analysis*

The instrumentation of the MEV and control vessel will begin at the start of the demonstration project and continue over the winter of 2022 before the vessels are re-entered into service for hire in 2023. Each will be equipped with a data logger to read sensors installed around the vessels. The data logger will be accessible remotely as a USB dongle will facilitate connection to the onboard wifi network which is connected to the 4G mobile network. Data can therefore be uploaded to the cloud at times of 4G connectivity for analysis. After each cruise, electrical systems will be checked and any adjustments made.

We will make use of various sensors including current transformers (CTs), energy meters, pulse flow meters and thermistors to take readings from subsystems on each vessel. These will be recorded on industry standard data loggers at predetermined intervals. Each vessel will be equipped with a GPS tracker to enable understanding of the distances it travels and the locations used for mooring and recharging. Meters on the ECPs will enable the recording of time and electricity units dispensed to the demonstration vessel. Fuel records will be kept for the control vessel.

Operational data will be analysed to assess the following key criteria:

1. Energy usage patterns and battery drain relating to each system.
2. Locations where the vessel has moored and taken on charge.
3. Times at moorings, duration of connection to charging pillar (ECP) and charge rate of pillar.
4. Hot water and space heating usage durations.
5. Temperature deltas between incoming cold water and outgoing hot water.
6. Volume of water consumed.
7. Temperature deltas within the cabin and outside ambient space.

8. Charging station activity (energy transferred etc.) and supplies of electricity from BA moorings and NBD boatyard.

To achieve this, we will attach CT current monitoring devices to the following systems on the demonstration boat:

- Propulsion motor
- Bow thruster
- Electric showers
- Other domestic hot water systems (hot taps)
- Space heating (living areas)
- Space heating (cabins)
- Cooking systems
- Domestic lighting circuit
- Domestic power circuit
- On-board electrical systems circuit
- Charging system (bi-directional meter recording energy consumed and energy exported)

We will also record litres of water consumed from the domestic water tank.

As far as is practical, we will attach consumption monitoring devices to the following systems on the control vessel:

- Fuel supplied to engine
- Fuel and electricity supplied to space heater
- Domestic water consumed
- Charge to domestic batteries from engine alternator
- Discharge from domestic batteries
- Power received from shore supply
- Power consumed when connected to shore supply

The granular data recorded will be used to provide real-world real-time knowledge of actual energy and water consumption across all systems at different times of day, in order to inform future decisions relating to on-board storage and charging requirements - which will directly affect both up-front and operational costs of the hire fleet of the future.

### User experience, social and economic analysis

In order to understand the impact of the user experience, social, and economic factors on the industry, we propose that during the demonstration, the following data collection and analysis is conducted. A detailed description of the reasons for specifying this social and economic analysis is given in Appendix 9.

#### *Customer feedback surveys and interviews*

Our feasibility study includes a survey of past Norfolk Broads Direct customers, to help us to understand public perception and anxieties surrounding electric boating ([Appendix 2](#)). All customers

who hire the demonstration vessel will be asked to complete a pre-arrival survey - to understand their expectations of the vessel, and a post-holiday feedback form covering the following areas:

- Ability to understand on-board energy availability in relation to their needs.
- Range anxiety - did they visit the locations they hoped to or did they curtail any journeys?
- Sufficient hot water and space heating to experience a comfortable holiday.
- Sufficient cooking capacity at the times required.
- Ability to access reserved moorings without conflict.
- Ease of connecting to charging infrastructure.
- Reliability and ease-of-use of on-board systems.

These requests will be sent automatically by Norfolk Broads Direct's booking system. Hirers will also be asked to write a short online 'log' each day of their experience - to help understand whether anxieties and concerns increase or decrease as they become familiar with the boat and its systems.

The data will be combined with the real-time monitoring data (see above) to establish whether any revealed customer concerns are well-founded.

#### *Booking and market analysis*

Our target audience will be "early adopters" who always want to hire the latest boat, and those who are particularly keen to make eco- and environmentally-friendly purchasing decisions.

In addition to measuring occupancy rate, booking lead times, and achievable sales price of the demonstration unit in comparison with similar traditional vessels, we will ask customers which factors persuaded them to choose the electric boat over the others.

We may use a system of dynamic pricing (similar to airline pricing) to measure customer demand at different price points, in order to understand whether customers are willing to pay a premium price for the latest, most eco-friendly boat. This will be affected by the inevitable knowledge that the boat is a "trial", for which customers may not be prepared to pay the highest prices.

The intention is to demonstrate not only whether an electric boat is technically feasible, but whether there is sufficient demand at a realistic price-point to make it economically viable to convert and operate a fleet of holiday cruisers on the Broads.

#### *Economic impact comparison*

We will record and compare the operating costs of the demonstration vessel and a similar traditional (unconverted) vessel, which will be our control vessel. Projections may then be made to represent future rollout of MEVs.

## 5.4 [Business case](#)

We now detail the business case for the proposed demonstration project and what we are seeking to test and evidence for our business case development and business growth plans.

### 5.4.1 Business case introduction

The energy usage research conducted and shown in Chapter 7 shows that switching to electricity as an energy source is, in theory, a viable option to decarbonise the Broads boating industry and beyond to other inland waterways. However, this change cannot be undertaken on the mass scale required without real world demonstration of the concept. This will develop valuable learning not only for the marine and shoreside technology configurations, but also gather essential performance data, adding confidence to user adoption of MEVs in the displacement of GHG-emitting fossil fuel vessels. A trial electrification of an inland cruiser is proposed to acquire the necessary data (operational and user experience) to prove that the switch to electricity is viable in the real world. Estimates of economic impacts on jobs and revenues in a future scale-up of MEVs operating on the Broads will also be made.

#### *Drivers for change*

The Broads boating industry must de-carbonise. It is the socially responsible course of action, although there are also many economic, political, and operational factors which drive the need for this change. The UK government has committed to making the UK a net zero carbon emissions country by 2050. The supply chain of diesel fuel and manufacture of internal combustion engines and components will be impacted by the motor industry's transition to electric vehicles - this fact is likely to increase the cost of running inland cruisers (as they widely depend on marinised versions of automotive engines and their parts) which in turn may make the Broads hire boat industry unsustainable. If the hire boat industry closes, then this will also impact the private owners of boats on the Broads – as many of the facilities and amenities required rely on the hire boat industry to continue to operate, and those private vessels must also decarbonise by 2050. Thus, a way to decarbonise the hire industry must be found for the sector as a whole - including the Broads as a tourist destination - to survive.

Eliminating fossil fuel boats on the Broads is an essential element of transitioning the region to Net Zero emissions. The overall UK marine leisure industry is estimated to generate £3.7 billion GVA and 28,000 jobs<sup>8</sup>, all of which depends on the industry adapting to a zero-carbon economy. In the Broads context, there were 8.18 million visitors in 2019, contributing £655 million per annum to the local economy, with Broads hire boat cruising alone providing a direct income of £20million per annum to the area. In addition, hire boats on the Broads currently provide the equivalent of around 1,500 hotel rooms, with associated overnight visitor spend.<sup>9</sup> If nothing is done, the future of Broads boating is in question. The Broads Authority receives over £3.5m in tolls annually, which is required to maintain

---

<sup>8</sup> The economic contribution of the UK leisure marine industry, A CEBR report for Maritime UK, CEBR 2019, <[https://www.maritimeuk.org/documents/188/Cebr\\_Maritime\\_UK\\_Marine\\_finalised.pdf](https://www.maritimeuk.org/documents/188/Cebr_Maritime_UK_Marine_finalised.pdf)>

<sup>9</sup> Using Norfolk Broads Direct data, the average occupancy across their fleet in 2021 was 3.7 persons/vessel. This is presumed to be typical across the 733 hire vessels. Presuming a typical hotel occupancy of 2 people per room, the Hireboat fleet is supporting the equivalent of 1,466 Hotel rooms (733\*2) - more than the total number of Hotel Rooms in the Broads Area of Influence.

the navigational area and environment for all types of vessel (not just motor cruisers). If the hire industry was to collapse, then external funding would be required to replace the lost income from tolls in order for the unique heritage of the Broads as a navigable waterway to be maintained. Users and managers of other inland waterways will benefit from this demonstration of a joined-up strategy to initiate a zero emissions transition, as it reaches beyond day boating and other short duration use cases.

As a result of this feasibility study, if a viable pathway can be found to decarbonise the target leisure cruising industry, we anticipate that this could eventually attract a greater number of visitors to the Broads due to its green credentials, leading to an expansion in the local economy and widen the scope of the market even further. It is therefore essential that we find an alternative fuel option to keep the sector thriving in a Net Zero landscape.

While there are existing electrified models for day cruising boats and decarbonised point-to-point ferries, there is currently no integrated market-ready solution for decarbonising leisure cruising vessels which are required to be away from base for many nights at a time. Existing options are often bespoke, and there is a particular need to focus on cost control in developing a boat for commercial hire operation. To resolve this gap in our understanding, the business case for the proposed demonstration aims to pave the way to satisfy the following needs:

1. A viable collection of integrated clean energy systems to provide self-contained propulsion, heating, domestic and ancillary services aboard leisure cruisers designed to operate at low speeds (below 10 km/h) on inland waterways.
2. A system of land-based charging infrastructure capable of eliminating range anxiety and ensuring that the Broads remains viable as a holiday destination following de-carbonisation.
3. Understanding the potential revenue from grid-balancing services by utilising MEV energy storage capacity outside the peak holiday season.
4. High resolution operational and user experience data of value to the wider sector and other geographies that will support the development of clean inland waterways economies.
5. Valuable IP concerning the technical solutions required to retrofit and build new electrified vessels with relatively low propulsion power (for slow cruising) compared to high onboard energy storage capacity.

### *Options Considered*

- **Retrofit a high-demand hire cruiser**
  - To retrofit a hire cruiser with electrically powered systems for propulsion, heating, and cooking.
- **Design a new electric hire cruiser**
  - To design a brand-new hire cruiser that uses only electricity as a source of energy.
- **Purchase an electric cruiser**
  - Purchase an electric motor holiday cruiser for holiday hire.
- **Hybrid and alternate fuel cruisers such as hydrogen fuel cell** (See [Appendix 5](#))
  - Hybrid systems, such as diesel-fuelled heaters and electric propulsion.
  - Hydrogen fuel cells.

With the above options considered, we decided to propose a retrofit of an existing cruiser because:

- It is estimated to be the least expensive option.
- Retrofitting will extend the life of existing cruisers, avoiding the emissions associated with disposal of otherwise serviceable boats, and construction of new hulls.
- The lifespan of an inland cruiser is far longer than cars – with many lasting 30-50 years before retirement. The changes in legislation which will force decarbonisation would not give enough time for the entire fleet of inland broads cruisers (both hire boats and privately owned) to be replaced and thus conversion will be the only viable option to keep the industry alive.
- No manufacturers are currently offering electric inland cruisers suitable for the needs of the Broads, so purchasing one “off the shelf” is not an option.
- Retrofitting will pave the way for quicker and better development of new cruisers.
- A hybrid fuel solution will reduce but not eliminate carbon emissions – so will not meet the requirement to achieve net zero by 2050. Given the long life of marine power trains, it would also effectively require existing boats to be refitted twice before 2050, increasing the overall cost of the transition. Based on the number of vessels that would need converting over the next 30 years, multiple refits would strain the capacity of Broads Boatyards to achieve Net-Zero. (see figure 7.9 & table 7.15)
- The current lack of availability of hydrogen fuel in Norfolk & Suffolk and the increased costs of developing hydrogen storage and fuelling infrastructure prohibit the use of hydrogen fuel cell technology, at least for the foreseeable future.
- Demonstrating electrical retrofits could nevertheless pave the way for future use of hydrogen fuel cells instead of on-board batteries, as onboard electrical system configurations should be compatible with hydrogen fuel cells as the energy source. Thus, developing knowledge of electrical retrofits can be viewed as a no-regrets investment.

We understand the Minimum Viable Infrastructure (MVI) in support of only one vessel to operate on electricity will require a disproportionate investment in terms of the returned benefits over the course of the demonstration, however this must be seen in the context of an energy transition to clean maritime emissions that will evolve over nearly 30 years. The return on investment for infrastructure for the operation of one boat will be poor, therefore the proposed demonstration business case is likely to be poor to prove the concept. However, the potential to use the Minimum Viable Infrastructure as a baseline to support the future roll out of MEVs will lead to a positive longer term return on investment, provided that the pilot is successful and there is a future take up of MEVs, which could potentially reflect the pattern of the road transport electrification transition.

Balancing the scale of the proposed demonstration against the level of investment required currently depends on a number of factors (introduced in Section 5.2) that influence the business case. For this reason, we have proposed – as a first step – a Minimum Viable Demonstration in Phase 2 with regard to the following constraints:

- The disproportionately high cost of marinised battery energy storage (compared to most other components of the demonstration) to be borne by the hire craft owner. For this

reason, we have proposed converting only one vessel, although we realise data to represent future operational realities would be better reflected by converting several vessels. Because of this we foresee, if commitment is made to electrification, a second, ‘scaled-up demonstration’ outlined in Table 5.2, below.

- The desire to avoid expensive ‘stranded assets’ such as vessels that underperform in hire sales (and need to be returned to their original state to support the hire business revenues) or an un-utilised charging infrastructure. This constrains the proposed demonstration in Phase 2 by allocating resources at the minimum level needed to carry out the demonstration. This will reduce risks carried by NBD and whoever pays for the shoreside infrastructure, in view of potential availability of centralised funding for infrastructure projects of this nature in future.

The scale of the MVI is likely therefore, to require a future expansion to a scaled-up version, should initial demonstration results prove a viable and positive outcome with an expansion of the number of electrified vessels (see Table 5.2, below).

<b>Table 5.2: Demonstrator options and deliverables</b>			
	Marine	Shoreside charging infrastructure	Data analysis and evaluations
Minimum Viable Demonstrator (MVD). Proposed for ETB Phase 2	Retrofit one President class vessel with battery electrified propulsion, heating and cooking systems. Data logging and monitoring equipment to acquire high resolution operational data. Desk based study of MEV2G opportunities.	One fast 22kW AC charger at the NBD boatyard plus up to ten 7kW AC chargers at distributed moorings. Third party payment and charger management system.	Ongoing in-service data analysis of system energy use. User experience surveys and analysis. Economic impact assessment. Design plans and lessons report on the build process and accurate scale-up costings.
Scale-up from MVD and MVI. Next step beyond Phase 2 - proposed as Phase 2 Plus	As above with 5 vessels.	One rapid DC charger at NBD boatyard plus up to 35 fast 7kW AC chargers spread across 15-20 locations. Third party payment and charger management system. Type 2 connectors used. And possible extension with static battery and solar panels.	As above with further IP development from learning on retrofits.

### 5.4.2 Business growth plans

Business growth through a clean maritime transition is possible once the learning from the MVD and a scaled-up demonstration prove it is technically and economically viable to retrofit existing hire cruisers. With the necessary shoreside infrastructure, any new vessels could then be commissioned to operate on electricity as the price point for diesel components rises above the level for electrical components. This could be accelerated with financial assistance from central government in line with the objectives of maritime decarbonisation and regional economic resilience. The outcomes of conducting the proposed demonstration of an electrified inland motor cruiser will be to pave the way through:

1. Showing that it is possible to run an inland cruiser on electricity without the need for an onboard generator.
2. Developing the technology, engineering skills and experience required to create an electrically powered inland motor cruiser.
3. Learning how existing cruiser designs will need to be adapted to account for differences in fuel source and systems such as insulation, lighting, heating etc.
4. Having a reference to data for electrical energy usage and range expected under typical operational conditions.
5. Identifying the economic impact and cost of putting in shoreside electrical infrastructure to support the change.
6. Gathering real-world data on customer booking patterns and user experience – aiming to answer questions such as - will an electric cruiser be booked rather than a diesel cruiser, will range anxiety prohibit the booking, will electric cruisers improve or detract from the experience?
7. Production of a planned cost of investment to convert or replace the existing fleet.
8. Providing data on charging infrastructure performance and inform decisions on new infrastructure locations and power requirements.
9. Signposting the way to lower environmental ecotoxicity and GHG emissions in the locations where electrified vessels displace fossil fuelled vessels.
10. Innovating and pathfinding through demonstrating a way to support take-up of electric holiday cruiser vessels, creating the first inland waterway in the UK where an MEV hire cruiser can operate without constraint.
11. Delivering a MVI, whilst not enough to deliver a roll out of full electrification in the Broads, will give a basis upon which the Broads Authority and other stakeholders can build out the network iteratively as the fleet electrifies.

### 5.4.3 Business case challenges

At the present time, the retrofit of existing hire cruisers to battery electric propulsion is deemed to be the simplest and most cost-effective option for the boat yards to decarbonise. But the current cost differential between ICE engines and diesel, compared to batteries and electricity, mean that the boat yards face enormous financial barriers which are likely to result in significant delays in the transition away from fossil fuels.

In order to encourage and accelerate a transition to an electrified hire cruiser fleet, we need to be aware of options available to improve the business case for boat yard owners, either by disincentivising diesel use, or making electrification more attractive. Table 5.3 below, indicates the impacts of the primary considerations we have looked at to improve the business case.

The proposed demonstration will inform the Broads Authority’s approach to incentivising the transition, including understanding the types of behaviour changes that are likely to be obstacles to a further transition.

<b>Table 5.3: Impacts on the business case</b>		
<b>Scope</b>	<b>Disincentivising diesel</b>	<b>Incentivising electrification</b>
Local	<p><b>Low impact:</b> Increased tolls - the toll is a small part of the cost of keeping a vessel, and also impacts all keepers of vessels who may not have the capital to change their engines.</p> <p><b>Medium impact:</b> Imposing a fleet conversion percentage requirement when renewing hire company licences (the short term cost could be prohibitive). See section 7 of the “Proposed navigation charges for 2022/23 in the navigation area and adjacent waters”<sup>10</sup></p>	<p><b>Low impact:</b> Reduced tolls for electric vessels - tolls already lower than diesel and further reductions would remove significant BA income.</p> <p><b>Low-impact:</b> Enabling access to flexibility markets concerning the local electricity distribution system so that MEV battery storage assets are more fully utilised, especially in off-season periods.</p> <p><b>Medium impact:</b> Centralised support for new connection / reinforcement costs to incentivise charging infrastructure rollout.</p> <p><b>Medium impact:</b> Development of new skills and knowledge base to support jobs in the green local economy.</p> <p><b>High-impact:</b> Ability to access cheaper rates of electricity for charging.</p> <p><b>High-impact:</b> Centralised support for skills training leading to the creation of new jobs in an emerging field.</p> <p><b>High-impact:</b> Plug in grants similar to those that have driven the EV transition on roads.</p>
National and international	<p><b>High impact:</b> broadening scope and level of the carbon price. Would be a strong push factor but would impact the whole economy.</p> <p><b>High impact:</b> Increased resolution within</p>	<p><b>Medium impact:</b> Widening access to national flexibility markets (currently limited due to geographic grid export constraints).</p> <p><b>High impact:</b> Pathfinding demonstration will provide IP and skills to access wider</p>

10

[https://www.broads-authority.gov.uk/\\_data/assets/pdf\\_file/0024/404268/Proposed\\_navigation\\_charges\\_for\\_2022\\_2023\\_in\\_the\\_navigation\\_area\\_and\\_adjacent\\_waters.pdf](https://www.broads-authority.gov.uk/_data/assets/pdf_file/0024/404268/Proposed_navigation_charges_for_2022_2023_in_the_navigation_area_and_adjacent_waters.pdf)

	national maritime decarbonisation policies to include holiday hire cruising.	geographic markets needing to decarbonise inland waterways craft across multiple sectors.
--	--	---

On balance, the business case for electrified hire cruisers can be improved using the above measures, but in the near-term, there are still two significant obstacles to overcome:

- The upfront capital investment needed. The ongoing cost of maintaining and charging boats may be manageable, but the upfront cost appears to be prohibitive. Potentially a decarbonisation loan scheme with very low interest rates.
- How the cost of shared infrastructure is socialised, particularly when the number of users will initially be low. This includes the recharging infrastructure as well as electricity distribution network reinforcement costs. This could require a third-party to install infrastructure with low/no capex to the local economy and then recoup over the life of the asset and/or a centralised programme where a percentage of contributions from different stakeholders are agreed and spread over time.

#### 5.4.4 Potential for value stacking using MEV batteries

An innovative opportunity exists to benefit the business case for investment in MEVs by applying at appropriate times, the potentially large scale of battery storage that will eventually accrue aboard fleets of hire cruisers. This could be achieved broadly through a combination of demand turn-up/turn-down, discharge of stored energy at a contracted time, or to avoid import requirements to a load (such as the boatyard) under contract.

The opportunities for innovation in marine vehicle-to-grid are now outlined with a view to future demonstration. Following the operational season end, while the retrofitted craft is moored at the NBD base, would be a good time to conduct a flexibility demonstration. The vessel would be connected via a bidirectional charging pillar to undergo MEV to grid flexibility service trials using a dynamic tariff for battery charging. This will enable a combination of possible models of operation, including:

- **Standard supply arrangement:** Boat yards could establish a supply arrangement that would provide a discounted rate for charging overnight, and secure an agreed export price during peak hours. This would not be the most profitable pathway but would enable the batteries to be regularly cycled during the off-season and could offset other energy usage ‘behind the meter’ at the boat yards.
- **Supply contract with serviced ‘flex’ PPA:** Subject to being able to secure sufficient export capacity, boat yards could look to securing a dynamic half-hourly tariff that gives access to the cheapest off-peak import rates, while agreeing a ‘flex’ PPA on the export of the power. This would be optimised by the supplier (or other third-party) to ensure that the marine batteries secure optimum revenue across short-term wholesale markets, national flexibility markets, or local flexibility tenders (at a future date).
- **Innovative local energy supply offering:** For locations where export constraints cannot be overcome, there are some alternative local energy supply solutions that could be explored.

For example, boat yards could act as local EV charging hubs, or could look to sell power to local businesses. This would deliver the greatest overall local benefit, but is not an easy arrangement to establish given the current legal and regulatory baseline for the energy market. Exceptions can be granted and the government does fund demonstration projects looking to establish Smart Local Energy Systems (SLES).

A bank of batteries acting as a single market unit could earn revenue through buying power off-peak and selling it back to the grid during peak times. Value can be achieved in arbitrage, but the shifting landscape for network charges will see greater use of peak and off-peak network costs from April 2022 and could diminish the revenue potential in certain locations.

As well as trading power, the batteries could provide balancing services to the grid such as via the Balancing Mechanism, Fast Reserve, Frequency Response and Short-term Operating Reserve. These markets are currently subject to minimum capacity requirements, meaning that until wider participation is allowed, or significant numbers of boats convert, participation would be difficult. Equally, some of these services require immediate discharge from storage assets lasting only a few seconds. The additional kit and export capacity required to achieve this could be more costly than the revenue potential, at least in the short term.

UKPN has shown increased utilisation of local flexibility for system balancing, and has expressed the need to unlock further local flexibility throughout its next price control period (RIIO2 2023-2028). However, the volumes procured are still very limited and the locations can shift from year to year.<sup>11</sup> With the advent of market-making platforms such as Picloflex it is clear that, for the flexibility services market to develop and for 'value stacking' by service providers to be possible, a closer level of engagement between DNO and service provider (ie. MEV operators) will be necessary - a sentiment reflected in a recent whitepaper by Delta-EE.<sup>12</sup>

Against these revenue opportunities, we must flag that there are significant export constraints in the Broads vicinity that might prevent boats on the Broads from acting as flexibility assets. There might be ways of managing this for demonstrator vessels, but it could be a challenge to wider electrification as the vessel batteries will need to be regularly exercised in winter to prevent degradation.

Given the uncertainty about when and if MEVs will be able to participate in these markets, what revenues will be achievable through participation and what the wholesale and network cost profiles will look like in future, mean that only a high-level thought-experiment can be included in this first phase study.

---

<sup>11</sup> The Picloflex tool gives an overview of current flexibility competitions effective in the area covered by the Broads. <https://picloflex.com/dashboard?competition=2VA9BzV>

<sup>12</sup> <https://www.delta-ee.com/whitepaper/whitepaper-distribution-system-operators-and-demand-side-flexibility/>

#### 5.4.4.1 Value stacking example - Revenue potential per boat (2019 values)

##### *Assumptions and context*

We assume that between 1 November and 28 February, the electric boats are not in use and are moored up in a marina. The example provides values on a £/boat/day basis across this four-month window. (For reference, UKPN suggested that under present conditions more than 2 boats exporting at the same time from the same location could be problematic, so establishing how to scale this opportunity requires further study).

Prices from the winter 2019-20 have been used on the basis that they offer a more representative baseline given the energy market turmoil in recent months. 2020-21 and 2021-22 are included for reference.

Without certainty on participation in national or local flexibility markets, we restrict this assessment to two scenarios: firstly, charging/discharging is actively managed for revenue generation and secondly, charging occurs in off-peak windows and then used on-site during the day to avoid costs.

##### *Scenario One*

The boat yard secures an arrangement whereby it can buy and sell electricity on a half-hourly basis. For simplicity we assume the System Imbalance Price as the benchmark, buying in the cheapest window and selling in the most expensive. This is very difficult to achieve in reality, as it would require near-perfect forecasting, but is an acceptable proxy for illustration purposes.

We assume that any given boat receives charge in one 30-minute window and discharges in another. They are charged and discharged once per day per boat. A 22kW connection could allow for a 12% charge/discharge in a 30 minute window (on the basis that a full charge takes four hours) and a 50kW connection could allow for a 25% charge/discharge (on the basis that a full charge takes two hours).

This does not account for whether this is the optimal pattern for battery health, but merely an illustration of potential opportunity.

On this basis, the revenue potential in the off-season is just under £87.50 per boat (22kW connection) or just over £182.00 (50kW connection). At this level, the administrative costs would significantly outweigh the revenue potential, only by establishing a larger number of boats participating, or gaining access to more lucrative flexibility contracts will this approach be attractive to boat yards.

That being said, the trend data for 2020-21 and 2021-22 off-seasons shows instances of exceptionally high half-hourly price volatility. If these shifts are enduring beyond the pandemic recovery and current geopolitical pressures, the offseason revenue potential could be £235-£490/per boat (2020 levels) or even £490-£1021/per boat (2021 levels).

Once the demonstrator infrastructure is established, with commercial and technical details confirmed, a bespoke optimisation model could be made that may present a more nuanced view of the opportunity.

### *Scenario Two*

The boat yard cannot export any meaningful volumes to the local grid, but still needs to exercise the boat batteries in the off season. We assume a very crude delineation between peak and off-peak pricing based on retail market indicators published by Ofgem for 2019, 2020 and 2021. While retail prices have moved up and down, the relative difference between peak and off-peak rates remains at around 11.3p/kWh. This is not likely to reflect the typical rates experienced by businesses as the Ofgem figures will be distorted in part by the default price cap for domestic consumers. Billing data for Norfolk Broads Direct indicates variation of up to 4p/kWh between peak and off-peak rates.

If the boat yard cannot export to the grid, there is still potential to avoid costs by using the batteries to buy cheap power overnight and use it onsite during the day. We can suggest a range of avoided costs on a £/boat/day basis. To achieve the values mooted, the boatyard may need to switch to an alternative energy tariff that allows for a third super-off-peak rate overnight.

Regardless of charger capacity, a boat battery could comfortably charge 75% overnight. For our specification, this would mean 63kWh available the next day for use by the yard. The Main Shed at Norfolk Broads Direct can use over 100kWh/day in the off season, meaning that two boats operating as buffer storage could potentially offer savings of between £4-£11.30/day, (equivalent to £242-£684 per boat per off-season.)

These figures do not account for the recent energy price surges that have seen unprecedented rises in near-term energy contract costs. Among other actions, the spike has seen initiatives from energy suppliers to incentivise consumers to not import from the grid at peak times. Should this trend continue, the value from avoided peak costs increases further.

Once the demonstrator is established, a cost-benefit calculation should be made against prevailing electricity retail prices and market offerings to accurately quantify value.

## 5.5 [Costs and funding requirements](#)

Following on from the business case, we now detail the different costs and funding requirements for the proposed Phase 2 demonstration. For any public funding requirements, we will outline why funding is required and why these costs cannot be financed in a different way.

In Table 5.4, below, we present a summary of annual costs expected for the duration of the demonstration. These are presented in more detail in [Appendix 8](#).

Table 5.4: Summary costs for Phase 2 demonstration				
	2022	2023	2024	Total

Capital Costs	£113,600	£438,940	£0	£552,240
Energy/fuel costs	£0	£5,500	£0	£5,500
Non-fuel operating costs	£36,300	£76,370	£36,020	£151,970
Contingency	£15,000	£54,000	£4,000	£73,000
<b>Total Cost</b>	<b>£164,900</b>	<b>£574,810</b>	<b>£43,300</b>	<b>£783,010</b>
Public Sector	£150,000	£565,300	£35,000	£750,000
Private Sector	£14,900	£9,510	£8,300	£32,710

### Why demonstration funding is required

The proposed demonstration will involve installing MEV charging infrastructure. If the demonstration does not support adoption of this infrastructure, then the installations will be worthless at the end of the project. There will be no residual value, so the depreciation charge will be 100%. If the demonstration supports adoption (and/or expansion) of the trialed infrastructure, then the infrastructural assets that we have installed will have a value. Any residual value in the infrastructure will be very low, and will only yield a benefit to its owner (Broads Authority) over a lengthy time period, as adoption of MEVs grows. It is not possible to predict the results, which is exactly why the demonstration is needed, but the results will determine whether the capital assets have any value or not at the end of the demonstration

Similarly, there will be some capital expenditure on retrofitting the demonstration and control vessels. Again, if the demonstration supports our chosen solution(s), then there will be residual value in the retrofitted vessel. The residual value, however, is unlikely to be any higher than the original vessel, with its original drivetrain and fittings. The value to its owner (Norfolk Broads Direct), lies in its ability to generate income from hire; the value of the boat is proportional to the income that it generates. If the demonstration is successful, and the MEV is retained intact, then there is no indication that its ability to earn income will be higher than in its original condition. If the demonstration points us in a different direction, then there will actually be a cost incurred in stripping the vessel of installed technologies and refitting the original ones.

### Funding Requirements

The project will continue to draw upon the commitment and resources of all of the current partners in order to succeed. The nature of the financial investment in materials and external expertise for the project cannot be undertaken by the relatively small businesses that operate in the UK Inland Waterways, and the Norfolk Broads specifically. The benefits that will accrue from the successful electrification of the Broads will be spread across the whole of the tourism industry and beyond.

There is no single entity or small group that will profit significantly, and can therefore afford to risk investing the significant capital required by the proposed demonstration project. There is no equivalent in UK inland waterways to Tesla, Nissan, Audi, VW or Mercedes with deep pockets and huge potential profits. The best that local boatyards can hope for is that someone will show them how they might keep their business alive post 2030 as net-zero policies on fossil fuel vehicles become law. Public sector funding will need to take the lead at this early stage, in order to demonstrate the viability of the technology and to provide confidence to the private sector. This is the very beginning of what will become a £150m refit of the hire cruisers on the Broads alone. Public sector support in identifying the right technology, and seed funding the huge investment required, is absolutely essential.

The project team has approached existing funders of EV and MEV infrastructure and powertrains. Despite their obvious enthusiasm and vocal support for the project, they are unwilling at this early stage to commit any significant funding. It is clear that private sector funding will become available before 2030, if a successful 'proof of concept' has been demonstrated.

### Estimates and Contingencies

Estimated costs are based on quotations provided by suppliers of the services and equipment that are required for the project. Formal quotes have been obtained from some suppliers, others have given their best estimates, based on the tightening market for EV materials and services. A realistic contingency has also been included, to take account of unforeseen and unexpected variations that might arise. Global events are giving rise to materials shortages and other supply chain difficulties that could not have been forecast with any certainty. The automotive EV market is growing rapidly and placing specific demands on the same supply chains upon which the demonstration project will rely. Pragmatic contingent sums should enable the project to meet the changing demands of the market, and deliver a successful project.

## 5.6 [Permits and permissions](#)

Chapter 6, 'Consideration of Regulations' provides a detailed account of the organisations with varying degrees of influence over decision-making in the inland hire cruiser sector. The following text details the required permits and permissions to carry out the proposed demonstration, addressing requirements from both the onboard and onshore perspectives.

### 5.6.1 Permits

#### *Onboard*

Hire Boat operators are required by the Navigation Authority to have a valid Boat Safety Scheme (BSS) Certificate for each vessel, to demonstrate that they meet the minimum safety requirements. The self-built demonstration vessel will require a BSS Certificate from day one to support hire boat operator's licence & toll applications, and the certificate must be renewed every 4 years thereafter. In order to align with the project timescales outlined in Section 5.7, it will be necessary to book the examination in advance of the operational launch of the demonstration boat in April 2023. It would

also be advisable for the project team to liaise directly with BSS to ensure the examiner is confident and preferably experienced in inspecting electric vessels. It is possible that the demonstration boat may provide BSS with the opportunity to train their examiners on electric drive boats.

### *Onshore*

Overhead cables are unlikely to be acceptable in the Broads - see policy DM19 (Utilities infrastructure development) of the Broads Local Plan.

In the absence of guidance specific to onshore boat charging infrastructure, the Code of Practice for Electric Vehicle Charging Equipment Installation should be used to ensure the final installation complies with the relevant requirements of BS 7671:2018 (The IET Wiring Regulations, 18th Edition) and where necessary, the Electricity Safety, Quality and Continuity Regulations (ESQCR) 2002 (as amended).

## 5.6.2 Permissions

### *Onboard*

The following standards should be adhered to. Standards specific to electric boats are being developed within the industry as the technology evolves.

**BS EN 60092 -507 : 2000** - Electrical installations in Ships. Pleasure crafts

**BS EN ISO 10133 : 2017** - Small craft. Electrical systems. Extra-low-voltage D.C installations

**BS EN ISO 13297 : 2021** – Small craft. Electrical systems. Alternating and direct current installations

**BS 7671 : 2018** - Section 709 Marinas and similar locations

**IEC 62196** - Plugs, socket-outlets, vehicle connectors and vehicle inlets – Conductive charging of electric vehicles.

Individuals working on the deployment of the demonstration project will be required to have knowledge and experience of delivering against the above standards. It is possible that additional training will be required for specific component parts.

### *Onshore*

Permission to install charging infrastructure – with its associated risks and timescales – depends on the location of the proposed charging point. The delivery of charging infrastructure on the Broads Authority moorings will in some cases depend on consultation with the freehold owners, as most of the sites are leased from third Parties. The sites selected for the demonstration project are either Broads Authority freehold, or land leased from Local Authorities with good relationships with the Broads, and with their own Climate Policies that support electrification in principle. The details for each site are set out in [Appendix 7](#).

In being selective with the location of new charging facilities, it is hoped that the charging infrastructure for the demonstration project can be assessed under The Town and Country Planning (General Permitted Development) (England) Order 2015, Part 12 Development by Local Authorities Class A, which allows the Broads Authority and/or Local Authorities to install 'electric vehicle charging points and any associated infrastructure'. However, it will need to be established with the Broads Authority that onshore boat charging infrastructure will be assessed in the same way as electric vehicle charging points. Should it be possible to assess the charging infrastructure as Permitted Development, this will significantly reduce the lengthy timescales associated with a formal planning process – previously identified as a critical element affecting the delivery schedule of the demonstration project. Planning permission will be required for any third party locations.

### *Lighting*

There will be specific considerations around the use of lighting for charging points. Trips & falls are a particular hazard at moorings, and are potentially lethal if a person falls into a river. The use of cables to charge boats adds a new hazard. Most marine electric pillars have inbuilt lights for this reason.

However, the Broads Authority will need to consider;

- Impact on nocturnal wildlife such as bats that hunt for insects along the rivers at night, and may be disturbed by lighting on banks in otherwise dark areas.
- Mitigating the impact on invertebrates that arise from LED lighting, as some studies have suggested LED lights may pose a particular risk to invertebrates.
- The Broads' have various Dark Skies Areas, with large stretches that are Level 2 on the Bortle Scale, and some that are Level 1 (the highest level). Any use of lighting should be minimised to preserve dark skies, as they form a key part of the attraction of the Broads.

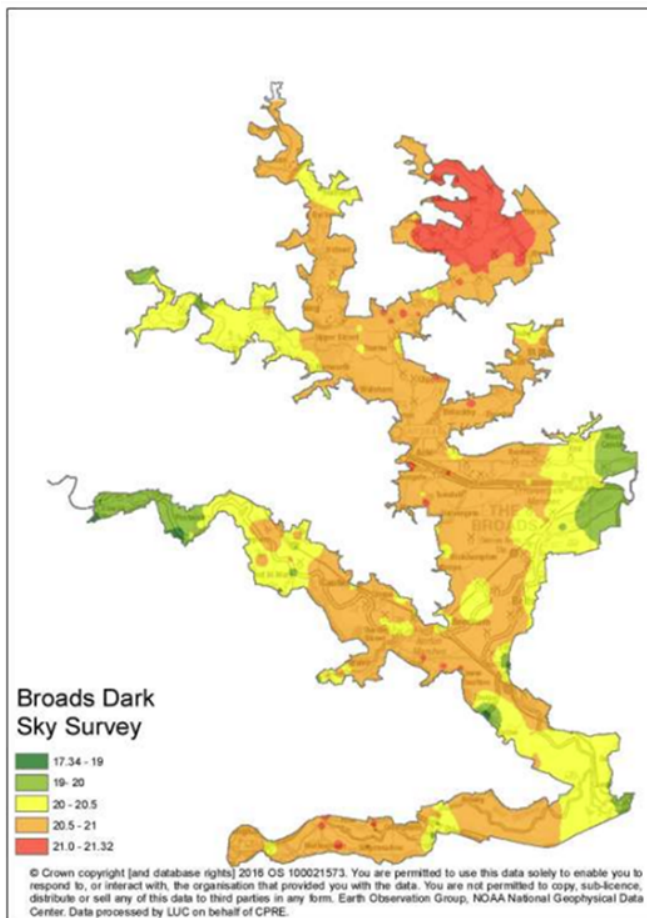

**Figure 5.6 - Dark Sky Areas in the Broads**

Figure 6.6 shows the darkest areas shown in Red, and the lightest areas (those adjacent to major settlements) shown in Green. The Dark Sky classifications of moorings are listed in Appendix 7. We do not foresee these impacts as being likely to prevent the installation of equipment, but they will have to be considered when selecting the equipment to be installed.

Prior written consent from the Environment Agency will likely be required as the proposed works will take place within nine meters of the main river. In addition, a works licence will also need to be obtained from the Broads Authority if the proposed works (temporarily) restrict access of a publicly navigable stretch of river. The timescales associated with seeking written consent from the Environment Agency and a works licence from the Broads Authority have been considered in the project timescales presented in Section 5.7.

## 5.7 [Delivery timescales](#)

We now detail the tasks forming the scope of work for the proposed demonstration project. The proposed demonstration will run for 18 months and a high-level delivery timescale is outlined in Figure 5.1, above.

Task ownership, milestones, stage gates, anticipated duration and bookend start and finish times are given in [Appendix 10](#). A full Gantt chart detailing tasks, ownership, duration and a critical path is presented in an accompanying file to this report (see Gantt\_10008242.pdf). We have also prepared a risk assessment as an accompanying file (see Risk\_Assessment\_10008242.pdf).

The proposed demonstration project (ETB Phase 2) is broken into four main project phases:

1. Project preparation (September - November 2022) - Detailed planning and preparation, surveying and hire season marketing ahead of the start of physical implementations. During this time we will confirm the current status of supply chains, procure the necessary subcontractor support in advance and submit planning applications to the relevant authorities. We will also prepare marketing and user experience surveys for the electrified and control vessels in advance of the 2023 hire season.
2. Project development (November 2022 - April 2023) - Practical implementation of the project will initiate during this time as retrofit of the demonstration vessel with electrical systems takes place. Instrumentation for data acquisition will be put in place for both demonstration and control vessels. Groundworks, installation and commissioning of shoreside chargers are also planned to take place within this time frame.
3. Run demonstration (April - November 2023) - All onshore and onboard systems are tested and monitored during this time as well as user experience sampling and evaluation. Any maintenance issues will be identified, reported and acted upon as well as notes on recommended changes to a scale-up of the MVD, as proposed in Table 5.2.
4. Data analysis and reporting (November 2023 - March 2024) - Whilst ongoing data collection and analysis from marine, shoreside infrastructure and user experience sampling will take place throughout the demonstration phase, the full picture will be analysed and evaluated in order to present the results and impacts in the final report by 31st March 2024.

The start time is contingent upon approval of the requested funding for this demonstration – however, given the nature of the project, it is essential to the success of the demonstration to have the detailed preparations in place in time for the start of the annual hire season, which begins in April 2023. For the project to proceed as planned, therefore, it is highly advantageous for the project team to know whether the demonstration is approved for funding as early in 2022 as possible - especially in view of the current widespread supply chain disruptions which are making the procurement of goods and services take far longer than normal.

## [5.8 Required collaboration and partners](#)

Most of the skills and knowledge required for the demonstration project are represented within the project team. Principally RenEnergy – who will provide the expertise necessary to manage the installation of the shoreside charging network, and Norfolk Broads Direct - who will carry out the removal of the existing fossil fuel systems and retrofit the electrical components.

Specialist design work for the drivetrain will be procured from Torqeedo - via their representatives in the UK, Coulam Marine, who are also experienced in manufacturing electric boats, albeit with lower

overall energy requirements. We have provisionally secured a design timeslot with Torqeedo to assist in developing the project, subject to funding being available for the demonstration (see accompanying Gantt chart for timings - Gantt\_10008242.pdf).

The Broads Authority are part of the project team, and most of the proposed locations for shoreside charging infrastructure are under their control - so land ownership issues should not present a problem for the demonstration. Where the land is leased or licenced from a 3rd party (such as Great Yarmouth and Norwich Yacht Stations), the landlords are local councils with an interest in supporting the project, and that have expressed support in principle for the project. The details for each site are set out in Appendix 7.

We will also work closely with South Norfolk Council, who have committed funding for the provision of EV charging points around their district, and have an emerging policy to support EV charging points at riverside pubs and restaurants. They have expressed a strong desire to work in partnership with the Electrifying the Broads project to deliver this policy, to ensure that our visions are aligned and that their charging infrastructure is physically compatible with the demonstration vessel.

Similarly, Norfolk County Council are developing policies to support EV charging across the county and we anticipate working closely with them as the demonstration evolves.

We also propose to establish a collaboration with the Broads Internal Drainage Board (IDB) and the Waveney, Lower Yare and Lothingland IDB in relation to possible sharing of their network capacity at pumping stations, as described in section 5.3 - to ensure that electrical infrastructure requirements in the Broads are planned together. This will be possible once their business cases for pump renewal are completed in June 2022.

## 6. CONSIDERATION OF REGULATION

In this section we lay out the regulation concerning our feasibility study and future demonstration project.

### 6.1 Maritime decarbonisation policy against the backdrop of Net Zero 2050

The UK Government has committed in legislation to achieving Net Zero emissions by 2050 and, to accomplish this, rapid and widespread decarbonisation must be achieved across all sectors. As a back-drop to this study we note the formative policy documents looking to drive decarbonisation in the maritime sector:

**2008** - Legally binding targets for GHG emissions reductions first set by the **Climate Change Commission (CCC)** and updated for 5-year periods going forward.

**2015** - **Maritime Growth Study**<sup>13</sup> flagged the need to take a more strategic look at the future of the maritime sector and recommended the development of a national strategy<sup>14</sup>.

**2019** - **Maritime 2050** from DfT which sets the strategic vision for the maritime sector, such that:

*“in 2050, zero emission ships are commonplace globally. The UK has taken a proactive role in driving the transition to zero emission shipping in UK waters... as a result the UK will successfully capture a significant share of the economic, environmental and health benefits associated with this transition”*<sup>15</sup>

**2019** - **Clean Maritime Plan** contains a national plan of action detailing how the Government sees the transition to zero emission shipping by 2050. It also encompasses the maritime commitments within the **UK Clean Air Strategy**.<sup>16</sup>

**2020** - **‘Ten Point Plan for a Green Industrial Revolution’**<sup>17</sup> includes policy proposals and funding packages including the Clean Maritime Demonstration Competition, of which this study is a recipient.

**2020** - **Sixth Carbon Budget (CCC)** recommends a 78% reduction in UK territorial emissions by 2035 (on 1990 levels). The Government adopted this target into law in April 2021.<sup>18</sup>

**2021** - **Transport Decarbonisation Plan** suggests a much broader range of measures to accelerate the decarbonisation of all vessels and schedules further consultations for 2022.

---

<sup>13</sup> <https://www.gov.uk/government/publications/maritime-growth-study-report>

<sup>14</sup> [https://assets.publishing.service.gov.uk/government/uploads/system/uploads/attachment\\_data/file/872194/Maritime\\_2050\\_Report.pdf](https://assets.publishing.service.gov.uk/government/uploads/system/uploads/attachment_data/file/872194/Maritime_2050_Report.pdf)

<sup>15</sup> Ibid. Page 4

<sup>16</sup> [https://prod-drupal-files.storage.googleapis.com/documents/resource/public/Roadmap-for-decarbonisation-vessels\\_v13.pdf](https://prod-drupal-files.storage.googleapis.com/documents/resource/public/Roadmap-for-decarbonisation-vessels_v13.pdf)

<sup>17</sup> [https://assets.publishing.service.gov.uk/government/uploads/system/uploads/attachment\\_data/file/936567/10\\_POINT\\_PLAN\\_BOOKLET.pdf](https://assets.publishing.service.gov.uk/government/uploads/system/uploads/attachment_data/file/936567/10_POINT_PLAN_BOOKLET.pdf)

<sup>18</sup> <https://www.theccc.org.uk/wp-content/uploads/2020/12/Sector-summary-Shipping.pdf>

**2021** - The **Net Zero Strategy**<sup>19</sup>, published October 2021, re-iterated some of the commitments made in the **Transport Decarbonisation Plan**, including the need for new consultations on supporting deployment of shore power and phasing out the sale of new non-zero-emission vessels.

**2022** - DfT will consult in mid-2022 to phase out the sale of new, non-zero emission domestic vessels, building on the experiences of the steps being undertaken in the decarbonisation of other modes of transport, such as the ban on new petrol and diesel cars from 2030.<sup>20</sup> It will also explore the option to establish a dedicated unit known as the 'UK Shipping Office for Reducing Emissions' (UK-SHORE) to drive decarbonisation. The UK-SHORE remit will include the issue of providing adequate shoreside electrical power infrastructure to meet the rollout of electric vessels and seek to understand more clearly the anticipated energy demand from electric vessels.

### 6.1.1 Maritime decarbonisation examples

As part of the policy context research, we identified a range of projects from the UK and Europe that are working to drive maritime decarbonisation. These examples differ in the target vessels and local conditions but illustrate the range of policy levers available to influence decision making and accelerate the transition to an electric vessel fleet.

The examples are summarised in Appendix 11, but the core policy actions included:

- Announcing clear and definitive deadlines for when fossil-fuel vessels will cease to be compliant
- Initiating bans on the most polluting vessels such as two-stroke outboard motors
- Placing additional taxes on polluting fuels and increasing the tax burden in regular, transparent intervals
- Offering financial support to offset the capex cost of retrofitting vessels
- Providing convenient charging infrastructure to enable operational viability in line with current usage

Whether any of these policies will be introduced in the Broads is subject to both the outcome of ongoing consultations and wider national policy changes. Local agents, such as district councils and the Broads Authority, also have a role in regulating vessels and vessel owners and could look to implement similar measures ahead of, or in addition to, national policy revisions. The levers for doing so are discussed in Section 6.3 below.

## 6.2 Local activity relevant to Net Zero 2050

The Broads spans 6 District Council Areas (South Norfolk, Norwich, Broadland, North Norfolk, Great Yarmouth, and East Suffolk), and two County Council Areas (Suffolk and Norfolk). These Councils have a mixture of policies on Net-Zero, however they are all committed to the area reaching Net-Zero no

---

<sup>19</sup>[https://assets.publishing.service.gov.uk/government/uploads/system/uploads/attachment\\_data/file/1033990/net-zero-strategy-beis.pdf](https://assets.publishing.service.gov.uk/government/uploads/system/uploads/attachment_data/file/1033990/net-zero-strategy-beis.pdf)

20

[https://assets.publishing.service.gov.uk/government/uploads/system/uploads/attachment\\_data/file/936567/10\\_POINT\\_PLAN\\_BOOKLET.pdf](https://assets.publishing.service.gov.uk/government/uploads/system/uploads/attachment_data/file/936567/10_POINT_PLAN_BOOKLET.pdf)

later than the national target of 2050. Several of the Authorities (North Norfolk, Norwich, Suffolk and East Suffolk) have set 2030 targets<sup>21</sup>. Both Norfolk and Suffolk have both formed Climate Change Partnerships which have representation from local authorities and aim to share knowledge and best practises for local authority responses to climate change, as well as looking at opportunities to influence wider transitional activities and behavioural change.

In addition, Norfolk County Council is developing an EV strategy in partnership with the Norfolk Climate Change Partnership (of which the Broads Authority is a part)<sup>22</sup>. Whilst this strategy focuses on electric road vehicles, there is a clear overlap with the ETB strategy as they will use the same supply chain, and face the same pressures in accessing the grid.

The Broads Authority is taking actions on these topic areas and has committed to become a 'Zero Carbon Area' by setting its own target to be carbon neutral by 2030, with a further objective of reducing all carbon emissions to zero by 2040.<sup>23</sup> On 27th September 2019, the Broads Authority adopted a Climate Change Emergency Statement in which the authority resolved to recognise a climate emergency, pledge to work towards its carbon neutral target, establish a baseline for CO<sub>2</sub> emissions and resultant action plan, offset residual carbon emissions via a 'Broads offsetting scheme' and – most relevant to this study – working with its constituent Local Authorities to reduce emissions from domestic use, travel and other sources.<sup>24</sup>

### 6.3 Potential interactions with regulation and regulators

The inland hire cruiser sector is not subject to intensive regulation, but there are a wide range of organisations that have varying degrees of influence over decision-making in the sector. We have commented briefly on organisations broadly considered as having an 'advisory' function on regulation, meaning they may influence decision-making, and may even shape financial support for demonstration projects, but they do not directly function as a regulator to the hire boat businesses.

For the purposes of this study, only **five bodies have been classed as having a direct regulatory role** (or equivalent level of influence). **Three are national frameworks:** the Boat Safety Scheme, National Planning frameworks and the charging infrastructure regulations, and **two are local accountable bodies:** the Broads Authority (as Navigation Authority) and regulated electricity network company, UKPN. We explore these five topics in detail below. The proposed body of UK-SHORE (mentioned in Section 6.1) may include a regulatory function, but is excluded here until more detail on its roles and responsibilities are available.

---

<sup>21</sup>

[https://netzeroeast.uk/wp-content/uploads/2021/11/Guide-to-Local-Authorities-and-Net-Zero-in-the-East-of-England-Volume-1-Norfolk\\_E.pdf](https://netzeroeast.uk/wp-content/uploads/2021/11/Guide-to-Local-Authorities-and-Net-Zero-in-the-East-of-England-Volume-1-Norfolk_E.pdf)

<sup>22</sup> <https://www.norfolk.gov.uk/news/2021/09/new-drive-to-accelerate-use-of-electric-vehicles>

<sup>23</sup> Climate change (broads-authority.gov.uk)

<sup>24</sup> Climate Change action plan (broads-authority.gov.uk)

Figure 6.1: A representation of the five principal areas of regulatory influence

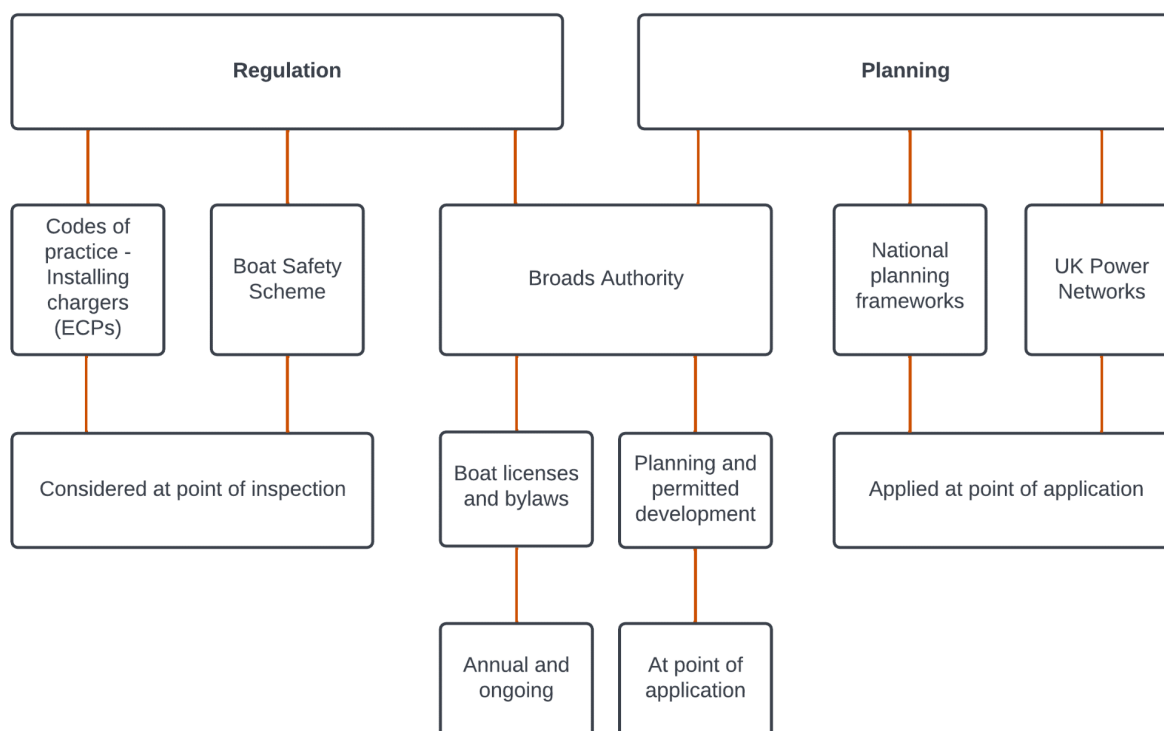

### 6.3.1 Advisory only

**AINA** - Association of Inland Navigation Authorities is the membership body “for organisations with statutory or other legal responsibility for the management, maintenance and operation of navigable inland waterways for navigation.” Depending on activities by other members, they may be placed to offer guidance on best practice.

**Industry policy specialists** - (Carbon Trust, CCC, leading consultancies) - Organisations such as these are continually refining their analysis and driving debate on policy and regulatory requirements. They may inform regulatory shifts, but won’t oversee their implementation.

**DfT** - The Department for Transport will be undertaking a range of consultations in the coming months on how to drive transport decarbonisation forward. This may include legislation such as new vessel bans, transition dates for existing vehicles and financial support packages. As the parties involved in this study are seeking to drastically reduce onboard emissions in the near-term, they will likely be implementing solutions ahead of any such regulations being imposed.

**BEIS and Ofgem** - There is a broad push towards electrification in transport and heat, which will be regulated by Ofgem. Ofgem’s priorities align with our aims to use the hire vessels as flexibility assets. For example, in September 2021, Ofgem set out its priorities for the transition to BEVs<sup>25</sup>. Its Priority Area 3 talks about promoting smart charging of Battery Electric Vehicles (BEVs) and the connection of vehicles to the grid, to support specific loads (V2L), buildings (V2B), the grid (V2G), or anything (V2X).

<sup>25</sup> [Enabling the transition to electric vehicles: The regulator’s priorities for a green, fair future, Sept 2021](#)

Ofgem promises to make it easier for BEVs to connect to the grid for two-way transfer of energy. Enabling policies such as these will be integral to the long-term success of electrification of the Broads hire cruisers. However, given that local constraints to the electricity network are a greater barrier to demonstration-scale activity in this area, we address this 'regulatory' topic under the section on UKPN.

**Defra and the Environment Agency** - The scope of these departments lies more in management of the local environmental and water conditions. Given that the parties involved in this study are seeking to drastically reduce onboard emissions in the near-term, they will also be supporting Environment Agency (EA) goals on water quality. Depending on the type and size of asset, as well as the proximity to the water courses, the EA may need to be consulted in the planning consent process (more on this in 6.3.3 below). This is unlikely to impact the demonstrator-scale project but may be of relevance for a wider roll-out of near-shore charging and energy storage infrastructure. The Environment Agency is also a Navigation Authority in their own right for some navigations in the Eastern Region, such as the Great Ouse navigation in Cambridgeshire & West Norfolk - but not the Broads.

**Local Authorities** - Local Authorities potentially influence around a third of an area's emissions through place-shaping and leadership.<sup>26</sup> An independent report for the Climate Change Committee suggests local authorities are at the heart of the climate conversation and in developing and replicating local solutions, with many of the urgent changes and decisions which are needed to reduce emissions and reach Net Zero having a strong local dimension.<sup>27</sup>

### 6.3.2 National frameworks - Boat Safety Scheme

The Boat Safety Scheme (BSS), is a public safety initiative owned equally by the Canal & River Trust and the Environment Agency.<sup>28</sup> Its purpose is to help minimise the risk to users of inland waterways and protect adjacent property. The BSS supports the Navigation Authorities by helping monitor and develop their minimum safety (legal) requirements. Meeting the navigation authorities' minimum legal safety requirements is a prerequisite to obtain a navigation licence on waterways controlled by the Broads Authority. Examinations are carried out by the BSS every 4 years on privately owned and privately managed vessels, and on hire boats to ensure all operating vessels meet the minimum legal safety standards.

The demonstration vessel will need to have a Boat Safety Scheme Certificate prior to launch to demonstrate the vessel meets the minimum safety requirements.

### 6.3.3 National frameworks - Planning

The *National Planning Policy Framework* (NPPF) 2019 and *National Planning Practice Guidance* (NPPG) are both material planning considerations. The NPPF sets out the Government's planning policies for England and how these are expected to be applied, while the NPPG sets out Government

---

<sup>26</sup><https://www.theccc.org.uk/wp-content/uploads/2020/12/Local-Authorities-and-the-Sixth-Carbon-Budget.pdf>

<sup>27</sup><https://www.theccc.org.uk/wp-content/uploads/2020/12/Local-Authorities-and-the-Sixth-Carbon-Budget.pdf>

<sup>28</sup> <https://www.boatsafetyscheme.org/about-us/>

guidance in relation to planning-related issues in England. Addressing climate change is one of the core land use planning principles which the NPPF expects to underpin both plan-making and decision-taking.

Paragraph 148 of Section 14 of the NPPF on Climate Change, Flooding and Coastal Change states:

*“The planning system should support the transition to a low-carbon future in a changing climate, taking full account of flood risk and coastal change. It should help to: shape places in ways that contribute to radical reductions in greenhouse gas emissions, minimise vulnerability and improve resilience; encourage the reuse of existing resources, including the conversion of existing buildings; and support renewable and low-carbon energy and associated infrastructure.”*<sup>29</sup>

Paragraph 154 goes further to say that:

*“When determining planning applications for renewable and low carbon development, local planning authorities should: a) not require applicants to demonstrate the overall need for renewable or low carbon energy, and recognise that even small-scale projects provide a valuable contribution to cutting greenhouse gas emissions; and b) approve the application if its impacts are (or can be made) acceptable.”*

The recommendations of the Climate Change Committee in *Net Zero: The UK’s contribution to stopping global warming*, published May 2019, identifies key near term actions to deliver against the climate targets.<sup>30</sup> It identifies lead-times for planning and delivering this infrastructure, particularly for new infrastructure, as a constraint for the deployment rate of technologies that rely on it.<sup>31</sup> For example, prior written consent from the Environment Agency is required for any proposed works or structures in, under, over or within nine metres of a main river or a flood/sea defence. Depending on the length and type of works proposed a water framework assessment may also be required.<sup>32</sup>

#### 6.3.4 National frameworks - Charging infrastructure

**Code of Practice** - The Government-recommended Code of Practice for Electric Vehicle Charging Equipment Installation provides guidance on the installation of electric vehicle charging equipment to assist the installer in ensuring the final installation complies with the relevant requirements of BS 7671:2018 (The IET Wiring Regulations, 18th Edition) and where necessary, the Electricity Safety, Quality and Continuity Regulations (ESQCR) 2002 (as amended).<sup>33</sup> Whilst the Code of Practice applies to the installation of dedicated conductive charging equipment for the charging of pure electric and plug-in hybrid electric road vehicles (PHEV), including extended-range electric vehicles (E-REV), it is widely acknowledged that recreational craft engines are mainly marinised automotive engines and

---

<sup>29</sup>[https://assets.publishing.service.gov.uk/government/uploads/system/uploads/attachment\\_data/file/1005759/NPPF\\_July\\_2021.pdf](https://assets.publishing.service.gov.uk/government/uploads/system/uploads/attachment_data/file/1005759/NPPF_July_2021.pdf)

<sup>30</sup><https://www.theccc.org.uk/publication/net-zero-the-uks-contribution-to-stopping-global-warming/>

<sup>31</sup><https://www.theccc.org.uk/wp-content/uploads/2020/12/The-Sixth-Carbon-Budget-The-UKs-path-to-Net-Zero.pdf>

<sup>32</sup><https://www.broads-authority.gov.uk/planning/planning-permission/design-guides/mooring-design-guide/permissions-and-notice>

<sup>33</sup> IET Standards, Code of Practice for Electric Vehicle Charging Equipment Installation, 4th Edition

therefore the publication is applicable to this study in providing guidance on the installation of the electric charging points around the Broads in the absence of industry guidance on boat charging.

**Earthing arrangements** - Earthing arrangements of the incoming power supply will need to be established to determine the type of earthing arrangements required for the Electric Vehicle Charging Equipment (EVCE) and whether this can be accommodated within the design specification of the charging equipment.

**Equipment design and specification** - Security of equipment in a public setting, protective devices in the form of circuit breaker and a separate residual-current circuit breaker (RCCB) and appropriate remote management either through a wired connection or GPRS are all valid considerations when specifying suitable equipment.

### 6.3.5 Local accountable body - the Broads Authority

As well as the national policy measures that are (or will) be implemented to drive decarbonisation, the Broads Authority have a number of roles and responsibilities through which they can look to influence vessel owners and operators.

As the following sections describe, there are opportunities to incentivise/discourage certain vessel types and support a transition to new behaviours. For example, the Broads Authority could implement compliance requirements at registration, apply a carbon tax (annual or one-off at registration), implement a fuel efficiency criteria based on engine type/age or introduce criteria around zero-emission dates for all new/existing vessels. There are also opportunities to introduce new mooring policies to ensure fair access to charging pillars. The extent to which any of these policy measures are deployed would be subject to consultation with local stakeholders.

#### *Navigation Bylaws*

The Norfolk and Suffolk Broads Act 1988 (amended by the Broads Authority Act 2009) outline bylaws enforceable within the Broads. Navigation Bylaws are in force throughout the Broads Authority navigation area and are the principal code of navigational conduct in the Broads. The bylaws also contain measures relating to public moorings, obstructions, navigation by minors, conduct following an incident, navigating under the influence, firearms and weapons in the navigation area, and safe speed and navigating with care.

*The Vessel Dimension Bylaws (1995)* impose maximum beam and length restrictions on vessels navigating in certain parts of the Broads Authority navigation area. There are no restrictions in place for vessels with a beam 3.8 metres (12ft 6ins) or less; however, bylaw 7 imposes a length restriction of 14 metres (46ft) on pleasure vessels navigating in certain waters.

*The Vessel Registration Bylaws (1997)* state 'No person shall moor, use or navigate a vessel on waters within the navigation area or permit a vessel to be moored, used or navigated on any such waters unless the vessel is a registered vessel; and there is in force in respect of the vessel a valid

registration certificate.<sup>34</sup> This bylaw only applies to vessels which in any one year are kept, used or navigated within the navigation area for more than twenty eight days and/or visits the navigation area on more than four separate visits.

Any person wishing to register a vessel with the Broads Authority must complete a registration form, which demonstrates compliance with the bylaws and calculates the annual toll charge to be paid in respect of the vessel. The total amount to be paid is calculated based on the square metre area and goes up as the area increases, at a rate depending on the type of craft.<sup>35</sup>

Data collected by the Broads Authority through the registration process and collection of annual toll charges enables the project to build a reasonably accurate profile of vessels occupying the Broads. The requirement for vessels to be registered and pay a toll also provides an existing means for future dissemination and enforcement of policy changes.

### *Hire Boat Licensing*

The Broads Authority obtained powers to licence hire craft under provisions in the Broads Authority Act 2009. The 2009 Act gives the Authority the ability to licence Hire Boats under the Public Health Acts Amendment Act 1907. The hire boat licensing conditions have been developed in consultation with the Broads Hire Boat Federation (BHBF) and are also based on the *Code for the Design Construction and Operation of Hire Boats Part 1 "The Hire Boat Code"* published by the Maritime and Coastguard Agency (MCA) through joint development with British Marine (BM) and the Association of Inland Navigation Authorities (AINA).<sup>36</sup>

Licences must be held for each hired powerboat and their operators must also be licensed under the Broads Authority hire boat licensing scheme. A hire vessel is defined under the 1907 Public Health Acts Amendment as 'a vessel that is let for hire to the public'<sup>37</sup>

The hire boat licensing scheme places an obligation on the operators of hire boats to fully comply with the licensing conditions. These include:

- number of passengers
- loading and stability calculations
- compliance with construction and equipment standards
- vessels with gas-fuelled equipment to be fitted and maintained in accordance with HSE Gas Safety Regulations 1998
- any changes to mechanically powered vessels must be subject to a stability and loading test of a type approved by the Authority
- use of buoyancy aids and lifejackets
- mechanically powered vessels to be fitted with a bilge pump
- the use of a boarding system on vessels with a freeboard height greater than 1 metre

---

<sup>34</sup> [Vessel Registration Bylaws 1997 \(broads-authority.gov.uk\)](https://www.broads-authority.gov.uk)

<sup>35</sup> <https://www.broads-authority.gov.uk/boating/owning-a-boat/tolls/annual-toll>

<sup>36</sup> <https://www.broads-authority.gov.uk/boating/owning-a-boat/Hired-powerboat-licensing>

<sup>37</sup> [https://www.broads-authority.gov.uk/\\_data/assets/pdf\\_file/0024/180591/Broads-Authority-Hire-Boat-Licensing-Guidance.pdf](https://www.broads-authority.gov.uk/_data/assets/pdf_file/0024/180591/Broads-Authority-Hire-Boat-Licensing-Guidance.pdf)

- any exposed moving parts within passenger accommodation must be fitted with a suitable guard.

Completion of the vessel registration form for each hire boat is a prerequisite to apply for a hire boat operator's licence to operate within the Broads. The completion of the vessel registration form, in addition to the hire boat operator's licence, enables the Broads Authority to build a comprehensive profile of boat users and their associated greenhouse gas emissions. Such forms will also play an important role in both communicating and enforcing policy change towards a greener Broads.

### *Planning - The Broads Local Plan*

The Broads is an internationally important wetland and designated protected landscape of the highest order with a status equivalent to that of a National Park.<sup>38</sup> As such, the Broads has its own planning authority for the Broads Executive Area with its own Local Plan and policies relevant to the challenges faced by the iconic wetland ecosystem.

The Broads Executive Area includes parts of Broadland District, South Norfolk District, North Norfolk District, Great Yarmouth Borough, Norwich City, and East Suffolk Council areas. The councils for those areas retain the local authority powers and responsibilities in the Broads area, with the exception of planning which is the responsibility of the Broads Authority.

Established in 1988, the Broads Authority is a Special Statutory Authority with a statutory duty to manage the Broads and is responsible for producing the Broads Local Plan 2015 - 2036 (Adopted May 2019), which sets the strategic vision and policies for the Broads and is used in determining planning applications.

Policies relevant to shoreside infrastructure include Policy SP3 Climate Change which states: 'renewable energy will be supported, subject to there being no adverse impact on the landscape, wildlife, navigation, recreational interest or other factors considered important in the consideration of any proposals.' The use of low emission and alternative fuel cars and boats and the provision of electric recharging points is also supported to adequately mitigate and manage climate change contribution from transport use.

Measures to support Policy SP3 Climate Change will only be supported if they comply with Policy SP7 Landscape Character. A Landscape Sensitivity Study has been carried out to assess the impact of wind turbines and solar panels to provide criteria to [planning applicants](#) and inform [policy](#). The [Landscape Character Assessment](#) forms the baseline of the study whereby the assessments are broken down by area and impact of the technologies.<sup>39</sup> The assessment considers the sensitivity of the Broads landscape to field-scale solar PV in addition to commentary on domestic roof-mounted solar PV where appropriate.

In addition to protecting landscape character, future deployment of onshore electric charging equipment must also comply with the criteria outlined within 'Towards a Dark Sky Standard' for the

---

<sup>38</sup> [https://www.broads-authority.gov.uk/\\_data/assets/pdf\\_file/0036/259596/Local-Plan-for-the-Broads.pdf](https://www.broads-authority.gov.uk/_data/assets/pdf_file/0036/259596/Local-Plan-for-the-Broads.pdf)

<sup>39</sup> <https://www.broads-authority.gov.uk/planning/planning-policies/landscape-sensitivity-studies>

protection of dark skies.<sup>40</sup> In line with National policies, the local plan will be reviewed with a new local plan adopted by 2025, covering the period up to 2041. Experience gained through the proposed ETB demonstration in phase 2 will inform the revision of policies to support the roll out of electric charging whilst being sympathetic to the landscape.

### *Planning - Permitted Development*

There are two potentially relevant forms of permitted development under the Town and Country Planning (General Permitted Development) (England) order 2015, Schedule 2, Part 2, Class E (*Electrical upstand for recharging vehicles*), and Schedule 2, Part 12 Class A (*Development by Local Authorities*).

Currently, shoreside electric charging for watercraft is outside of the scope of Part 2 Class E permitted development that allows for private individuals and organisations to install off-street chargers (*The installation, alteration or replacement, within an area lawfully used for off-street parking, of an upstand with an electrical outlet mounted on it for recharging electric vehicles*).<sup>41</sup>

If such a permitted development were brought in at a National level for navigations, it could be similar to the current permitted development for car chargers. This could also potentially be used for chargers which are dual use - able to be used for both charging cars and boats (not included in proposed demonstration).

For an off-road charging installation to be classed as permitted development, the electrical upstand and the outlet must not:

- Exceed 2.3 metres in height from the level of the surface used for the parking of vehicles. This limit is 1.6 metres where in the curtilage of a dwelling/house or block of flats
- Be within two metres of a highway
- Be within a site designated as a scheduled monument
- Be within the curtilage of a listed building
- Result in more than one upstand being provided for each parking space.<sup>42</sup>

Unlike for private individuals or organisations, chargers that are installed by the Broads Authority or another Local Authority fall under Part 12 Class A, which allows a Local Authority to install 'electric vehicle charging points and any associated infrastructure'.<sup>43</sup>

Therefore for the demonstration project, we will seek to install the charging infrastructure on BA land as far as possible to speed up initial implementation and reduce planning costs. In the longer term,

---

<sup>40</sup> <https://www.darksky.org/towards-a-dark-sky-standard/>

<sup>41</sup> Schedule 2, Part 2, Class E of The Town and Country Planning (General Permitted Development) (England) Order 2015 (as amended) states that planning permission is not required for the installation of an upstand with an electrical outlet mounted on it for recharging electric vehicles, as long as the area is lawfully used for off-street parking.

<sup>42</sup> [https://www.planningportal.co.uk/info/200130/common\\_projects/16/electrics/2](https://www.planningportal.co.uk/info/200130/common_projects/16/electrics/2)

<sup>43</sup> The Town and Country Planning (General Permitted Development) (England) Order 2015, Schedule 2

the Broads Authority will engage with the Department for Levelling Up, Housing & Communities to discuss how permitted development can be amended to support future electrification.

#### [Planning - Permissions for waterside development](#)

Waterside development, including new and replacement works, will in most instances require planning permission from the Broads Authority. In addition, prior written consent from the Environment Agency is required for any proposed works or structures in, under, over or within nine metres of a main river or a flood/sea defence. Depending on the length and type of works proposed a water framework assessment may also be required.<sup>44</sup>

In accordance with the Norfolk and Suffolk Broads Act 1988, a works licence will also be necessary for the design and timing of installation of work which affects a publicly navigable stretch of river. A works licence can be obtained from the Broads Authority.<sup>45</sup> The requirement for prior written consent from the Environment Agency and works licence from the Broads Authority will need to be established and built into any project delivery timescales.

#### 6.3.6 Local accountable body - UKPN (Distribution Network Operator)

While there may be opportunities to establish off-grid charge points, the majority of the charging equipment installations are likely to require grid connections. The maximum demand of the existing supply needs to be established to make sure the additional draw from vessel charging can be facilitated. As the grid in and around the Broads is relatively weak and constrained, there are a number of competing pressures felt by UKPN.

They are a regulated monopoly required to deliver safe and reliable connections to consumers and developers. This overarching aim means that careful consideration on what type/size/behaviour of new sources of electricity demand (or supply) they can permit without jeopardising safety and reliability of existing connections.

Where the Maximum Demand (Load), including the addition of the new EVCE of a property is less than or equal to 13.8kVA, the DNO must be notified of the install within one calendar month of the installation. Where the Maximum Demand (Load), including the addition of the new EVCE of a property is greater than 13.8kVA, or an issue has been identified concerning the safety of the existing service equipment, the DNO should be contacted prior to installation.

Should there be an insufficient power supply or multiple chargers are proposed within a close geographic region, an assessment will be required by the DNO of the impact of the connections on the network and/or to upgrade the incoming power supply.

Notifying the DNO of intentions to connect into the local network enables the DNO to track increases in demand and thus mitigate the risk of distribution substation overloading and of voltages on the

---

<sup>44</sup> <https://www.broads-authority.gov.uk/planning/planning-permission/design-guides/mooring-design-guide/permissions-and-notice>

<sup>45</sup> [https://www.broads-authority.gov.uk/\\_data/assets/pdf\\_file/0024/184317/Navigation-Works-Guidance-2019.pdf](https://www.broads-authority.gov.uk/_data/assets/pdf_file/0024/184317/Navigation-Works-Guidance-2019.pdf)

distribution network moving outside statutory limits.<sup>46</sup> There is also a secondary consideration whereby UKPN has obligations to support an electricity grid suitable for Net Zero. Along with this commitment comes the requirement to facilitate and use local sources of flexibility to balance the system.

## 6.4 Discussions with regulators

Here we note engagement which has taken place to date with relevant regulators (or equivalent). Additional engagement would be needed before and during any subsequent demonstrator project.

<b>Regulator (or equivalent)</b>	<b>Discussions</b>	<b>Mitigation measures for next phase</b>
Broads Authority (as lead planning authority)	Active participant in feasibility study and designing demonstrator	Continued internal BA engagement to ensure applications meet all requirements
UKPN	<p>7-22kW chargers are easier to install than 50-150kW. Issues with harmonic disturbance with DC chargers. In general more than 3 such chargers requires their own substation, which comes at a cost of £100k.</p> <p>Any new UKPN infrastructure would need to be raised to avoid future flood risk, and can't sit on floating pontoons.</p> <p>Will be moving to shallow connection charging from April 2023, though what the transitional arrangements are for projects connecting before this date are TBC.</p>	Early engagement to ensure progress in line with demonstrator timelines, including requesting a dedicated liaison officer for the course of the project
Boat Safety Scheme	Not discussed during project span	We would potentially just need to arrange a call with an inspector to ensure they are prepared in advance to conduct the relevant safety tests.

---

<sup>46</sup> Ibid.

## 6.5 Summary of issues that may be encountered at the demonstration phase

Table 6.2 below, summarises the regulatory risks involved in a future demonstration phase. Please refer to our risk assessment\_for a more expansive list of topics (Risk\_Assessment\_10008242.pdf).

<b>Table 6.2: Regulatory issues that could be encountered in the proposed demonstration</b>		
<b>Issue area</b>	<b>Issue</b>	<b>Mitigation measures for next phase</b>
Planning	Delays in processing - either from complexities around jurisdiction, or awaiting EA approval	Will need to fully build-in contingencies to project timescales
Planning	Application declined due to not meeting requirements	Unlikely to submit an unsuitable application given BA involvement
Inspection - chargers	Post-construction checks reveal sub-standard charging equipment or wiring practices have been used, resulting in duplication of work or revoked planning permission	We will use accredited specialists such as RenEnergy to install relevant EVCE
Inspection - boats	Does not pass Boat Safety check	Installation will be undertaken by professionals, adhering to guidelines of component manufacturers
Connections	UKPN are unable to offer connections at preferred locations within budget or timescales	This feasibility study has given some indicative views on charging location viabilities. This can be used as a baseline on which to progress.
Connections	UKPN limit export capacity, limiting ability to participate in flexibility markets	Merits its own innovation demonstration competition. Group to propose to UKPN to take forward

## 7. LIFECYCLE EMISSIONS

In this section we present our analysis of lifecycle emissions.

### 7.1 Challenges in quantifying emissions from inland waterways leisure vessels

Setting the context for the Electrifying the Broads study, at the national level it is difficult to assess the value of inland vessel decarbonisation due to the significant diversity in the number, use and type of vessels at different locations. The different Navigation Authorities hold no centralised record of vessels registered in UK waterways and each Authority reports a limited amount of data, such that the age of vessels is not always captured during the registration process. Data is sufficient for the purpose of licensing but not for making accurate greenhouse gas emissions estimates. It is our hope therefore that this study will contribute to making some quantification of emissions savings possible.

<b>Category of craft</b>	<b>Numbers</b>
Private "leisure only" licence (circa 90% of Licenced boats). of which ~37% identify as "full or part time residential use" and ~20% are "Continuously Cruising" (no home mooring)	circa 31,000 circa 11,400 circa 6,000
Business boats (10%), including holiday hire, day hire, skippered passage, commercial trading boats and work boats	circa 3000
Boats claiming "Historic Boat" discount	76
Boats claiming "Electric boat" discount	101

Vessels have very different usage patterns, that can be impacted by factors such as:

- **Season:** Leisure boats, and particularly hired leisure boats, see strong variation between summer and winter. The busy season traditionally starts with the Easter holidays and runs until the end of the October half term although, more recently, the operating season has extended through November towards Christmas due to the growing demand for staycations. A few operators run a restricted fleet throughout the winter. Private owners may choose to use their vessels in the shoulder seasons to avoid peak visitor numbers.
- **Vessel size:** There is considerable variation in the size of engine-powered vessels, starting with small dinghies with outboard motors to large pleasure cruisers with inboard engines.
- **Vessel functions:** As well as energy use in propulsion, vessels designed to provide overnight accommodation will have to feature ancillary heating and cooking facilities, as well as

<sup>47</sup> AINA, 2019

optional functions that cater for personal devices and on-board entertainment. These additional functions incur additional fuel/energy use.

- **Purpose:** Vessels which are solely for leisure purposes tend to travel shorter distances on any given day. In fact, the majority of UK inland vessels travel less than 25km per day (See Figure 7.1, below).
- **Ownership:** Hire cruiser users tend to travel further in a shorter time than the great majority of private cruiser boats. The time-restricted access to the vessel creates a drive to make the most out of the time.
- **Age:** The age of the vessel and/or the age of the engine will have a significant impact on emissions. Due to the light wear, it is not uncommon for combustion engines 25 years or older to be powering vessels. This can have an important bearing on estimating emissions. Vessels built after 2005 should comply with the Recreational Craft Directive<sup>48</sup> engine standards, but this is hard to monitor and enforce in the current framework.
- **Location:** Certain beauty spots attract boating traffic and there can be more vessels clustered at any one time compared to other stretches of the waterways.
- **Compliance checks:** Unlike road vehicles going through MOT processes, there are no emissions checks to determine compliance. This is partly a practical issue as most exhausts will be near the waterline and the current Boat Safety Scheme (BSS) rules allow checks to be undertaken out of the water (i.e., a water-cooled engine cannot be run) and the engines do not need to be started.<sup>49</sup>

Figure 7.1. Distances travelled by inland waterways vessels (AINA data, 2016)

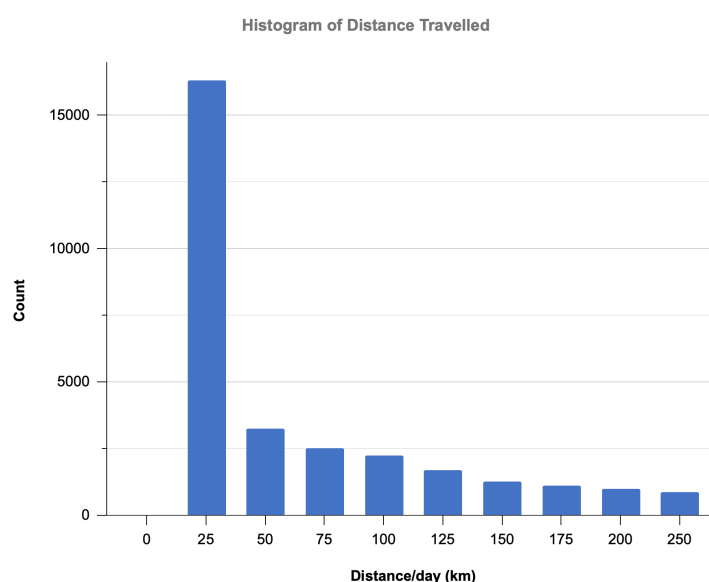

<sup>48</sup> <https://eur-lex.europa.eu/legal-content/EN/TXT/HTML/?uri=CELEX:32013L0053&from=EN>

<sup>49</sup> The Boat Safety Scheme, or BSS, is a public safety initiative owned by the Canal & River Trust and the Environment Agency. <https://www.boatsafetyscheme.org>

## 7.2 Approach to estimating greenhouse gas emissions savings from vessels on the Broads

The challenges described above at the national level are also true at the Broads level and are in evidence in the following analysis. Our approach to estimating the potential lifecycle GHG emissions savings by ‘Electrifying the Broads’ is based on the requested emissions deliverables from UKRI Phase 1 final reporting guidance, as follows:

*Detail any calculation and evidence there is from the project on life cycle emission savings achieved by the technology. This should include all upstream and operational emissions, splitting these out, over the lifetime of the equipment/vessel/infrastructure. These should be provided in a table per year (e.g 2024, 2025, 2026 etc.) so that any changes in emissions over the lifetime of the project can be captured.*

1. *Per unit basis e.g per unit of energy delivered or per unit of transport work.* We established the per unit basis as ‘kgCO<sub>2</sub>e/cruise night’ and derived emissions savings.
2. *For a given size of project in tonnes(CO<sub>2</sub>e)/annum for each year of the project (i.e for the project outlined in the ‘Detailed and Costed plan for demonstration project.)* We carried this analysis out for a single hire season as well as the life of the principal electrical equipment.
3. *In a potential operational setting if the technology were to reach market and be deployed at scale.* We extrapolated the results further to 2050 to correspond with the typical lifespan of vessels, using a standard technology diffusion curve to reflect the uptake of MEVs within the Broads fleet.

Greenhouse gas emissions (identified where possible) and CO<sub>2</sub>e values were calculated in accordance with the Greenhouse Gas Protocol reporting basis of Scope 1, 2 and 3 emissions.<sup>50</sup> Upstream and operational emissions conversion factors were taken from the year applicable across 2018-21, for example UK Government Conversion factors, 2021.<sup>51</sup> The conversion factors used are presented in Table 7.2, below.

For the boundary of scope 3, we have chosen to include the scope 3 of fuel production to be equivalent to the full costs of electricity production. We have excluded the machinery on the grounds of simplicity, but included the battery as this is known to be one of the largest embedded carbon sources in a battery powered vehicle or vessel.

<b>Scope 1 Conversion factors</b>	<b>Unit</b>	<b>kg CO<sub>2</sub>e</b>	<b>kg CO<sub>2</sub></b>	<b>kg CH<sub>4</sub></b>	<b>kg N<sub>2</sub>O</b>
Gas oil, 2018	litres	2.97049	2.72417	0.00298	0.24335
GTL, 2019 (100% mineral diesel )	litres	2.68697	2.65242	0.0003	0.03425
GTL, 2020 (100% mineral diesel )	litres	2.68787	2.65242	0.00025	0.0352
Cooking LPG (Propane), 2018	kg	2.93732	2.93341	0.002	0.00191

<sup>50</sup> <https://ghgprotocol.org/blog/new-global-framework-measure-greenhouse-gas-emissions-cities>

<sup>51</sup> [Conversion factors 2021: full set \(for advanced users\) - GOV.UK](https://assets.publishing.service.gov.uk/government/uploads/system/uploads/attachment_data/file/10008242/conversion-factors-2021-full-set-for-advanced-users.pdf)[https://assets.publishing.service.gov.uk/government/uploads/system/uploads/attachment\\_data/file/10008242/conversion-factors-2021-full-set-for-advanced-users.pdf](https://assets.publishing.service.gov.uk/government/uploads/system/uploads/attachment_data/file/10008242/conversion-factors-2021-full-set-for-advanced-users.pdf)

Cooking LPG (Propane), 2019	kg	2.93686	2.93301	0.00194	0.00191
Cooking LPG (Propane), 2020	kg	2.93881	2.93482	0.00214	0.00186
<b>Scope 2 Conversion factors</b>					
Electricity generated (2021)	kWh	0.21233	0.21016	0.0008	0.00137
AC fast charger (22kW) LCA*	kWh	0.50343			
<b>Scope 3 Conversion factors</b>					
T&D- UK electricity	kWh	0.01879	0.0186	0.00007	0.00012
Gas oil, 2018	litres	0.63253			
GTL, 2019 (100% mineral diesel )	litres	0.62617			
GTL, 2020 (100% mineral diesel )	litres	0.62611			
Cooking LPG (Propane), 2018	kg	0.36940			
Cooking LPG (Propane), 2019	kg	0.36930			
Cooking LPG (Propane), 2020	kg	0.35934			

\* Includes operational electricity (Scope 2 & 3) in use phase.

\*\* This value represents 'cradle-to-gate' emissions of primary materials, including extraction, processing, manufacturing and transportation to the point of sale, not the use phase emissions or offsets from material recycling.

The Department for Business, Energy and Industrial Strategy (BEIS) make the following recommendations when considering conversion of fuel energy:

*“Heating value is a very significant property of diesel [and LPG] fuels, because it gives the energy content of the fuel. The heating value is expressed as gross and net calorific value (CV), depending on the status of water present in the exhaust. If water is present as liquid, then the heating value is called the gross calorific value. If water is present as vapour, then the heating value is called net calorific value. In real operating situations, water in exhaust gases is present as vapour, so net calorific value is more important for energy efficiency calculations”.*<sup>52</sup>

For the purpose of estimating GHG emissions and CO<sub>2</sub> equivalent, we adopted the government's recommendations for recording Scope 1 emissions, which recommend using net calorific value.

### 7.2.1 Lifecycle emissions

Lifecycle emissions are normally calculated within set boundaries, on the basis of different emissions arising from 'use phase' (operation), 'materials extraction and processing', 'manufacture', 'transport to operational site' and 'disposal', over the lifecycle of an entity. A full lifecycle analysis of the proposed demonstration and the control vessel for deriving absolute savings is considered to be beyond the scope of this study.

52

[https://assets.publishing.service.gov.uk/government/uploads/system/uploads/attachment\\_data/file/990661/conversion-factors-2021-condensed-set-most-users.xlsx](https://assets.publishing.service.gov.uk/government/uploads/system/uploads/attachment_data/file/990661/conversion-factors-2021-condensed-set-most-users.xlsx)

However, we have taken values for upstream emissions where available that were quoted in UK government conversion factors for reporting Scope 1, 2 and 3 emissions making up key elements of the proposed demonstration. Upstream emissions for shoreside MEV chargers were obtained from Kabus, et. al, for 22kW AC fast chargers in Germany.<sup>53</sup> From this source we selected the emissions associated with the 'charging infrastructure', 'power electronics' and 'enclosure' elements of the charger and substituted UK electricity emission values (Scope 2 and 3) for the German electricity carbon intensity when calculating the 'use phase', or operational, element. Operational emissions for electricity use were based on UK government conversion factors (Scope 2).

Data on general electrical equipment upstream emissions is currently very sparse. Because of this we elected to discount the upstream retrofit equipment emissions as much of this was unaccountable without a full life cycle study, apart from estimates for the proposed battery. Li-ion batteries are accounted for under Scope 3 emissions in UK government conversion factors, but must be caveated as per note \*\* under Table 7.2, above. A more detailed analysis has proposed 73 kgCO<sub>2</sub>e/kWh for Li-ion batteries made in the USA<sup>54</sup> and as low as 56 kgCO<sub>2</sub>e/kWh for Li-Ion 30kWh batteries made in Europe.<sup>55</sup> A recent paper from IVL, the Swedish Environmental Research Institute has found that the scale-up of battery weight and capacity (in kWh) results in a near linear increase in Scope 3 emissions.<sup>56</sup> Adopting this advice, we can estimate our upstream battery emissions as follows:

Scope 3 emissions due to 84.4kWh battery =  $84.4 * 56 = 4,726$  kgCO<sub>2</sub>e

This large portion of a system's life cycle emissions is also found in LCAs of road-based EVs, and places emphasis upon the carbon content of the electricity in the use phase to create an overall improvement in comparative emissions with an ICE vehicle driven over the same distance. In a paper by Volvo, the addition of the battery emissions to the LCA, increased the EV carbon footprint by 70%, yet when the use phase (driving both vehicles for 200,000 km) was considered, the life cycle emissions of the EV were around 54% less than the ICE, if electricity from wind turbines was used to recharge the battery (and about 29% less if recharged on EU-28 electricity mix).<sup>57</sup>

We have accounted for UK electricity generation (Scope 2) as well as Transmission and Distribution losses (Scope 3) in our analysis, to address the use phase of the battery and shoreside charger elements in the calculations to follow.

In the emissions savings calculations that follow, we discounted the upstream emissions from materials and equipment (engines, tanks, pipes, hydraulic components, etc) in the control vessel as well as other electrical equipment (apart from the batteries and 22kW AC shoreside charger) in the proposed demonstration (control) vessel. Electrical fridges were discounted from our calculations because both retrofit and control vessels have these onboard, making the comparison of null value.

<sup>53</sup> Kabus, M., et al., 2020, Environmental Impacts of Charging Concepts for Battery Electric Vehicles: A Comparison of On-Board and Off-Board Charging Systems Based on a Life Cycle Assessment.

<https://www.mdpi.com/1996-1073/13/24/6508>

<sup>54</sup> [https://www.transportenvironment.org/wp-content/uploads/2021/07/2019\\_11\\_Analysis\\_CO2\\_footprint\\_lithium-ion\\_batteries.pdf](https://www.transportenvironment.org/wp-content/uploads/2021/07/2019_11_Analysis_CO2_footprint_lithium-ion_batteries.pdf)

<sup>55</sup> [https://theicct.org/sites/default/files/publications/EV-life-cycle-GHG\\_ICCT-Briefing\\_09022018\\_vF.pdf](https://theicct.org/sites/default/files/publications/EV-life-cycle-GHG_ICCT-Briefing_09022018_vF.pdf)

<sup>56</sup>

<https://www.energimyndigheten.se/globalassets/forskning--innovation/transporter/c243-the-life-cycle-energy-consumption-and-co2-emissions-from-lithium-ion-batteries-.pdf>

<sup>57</sup> <https://www.volvocars.com/images/v/-/media/market-assets/intl/applications/dotcom/pdf/c40/volvo-c40-recharge-lca-report.pdf>

Scopes 1 and 3 emissions were included for diesel fuel burnt in vessel engines and heaters, and an estimate of emissions from cooking fuel was also included. Scope 3 emissions arising from the diesel engine itself and associated components were not included.

An initial comparison of the savings from electrification over fossil fuel vessels was then made. However, as this is a crude comparison based on fuel energy substitution (diesel to electricity), we built an additional bottom-up estimate of subsystem electrical energy requirements for comparable operation of the demonstration vessel to the control vessel and derived the emissions savings from that as well.

The wider Broads fleet fossil fuel emissions were calculated from a survey of sales receipts in 2021, conducted by the BA of 20 fuel outlets located at boatyards supplying vessels on the Broads.

A summary of the approach we used to gather the data for calculating the three deliverables in the list above is shown in Figure 7.2, below. Green boxes represent principal inputs, white boxes, supporting activities and red boxes the principal outputs:

**Figure 7.2: Summary of approach to calculating reported emissions parameters**

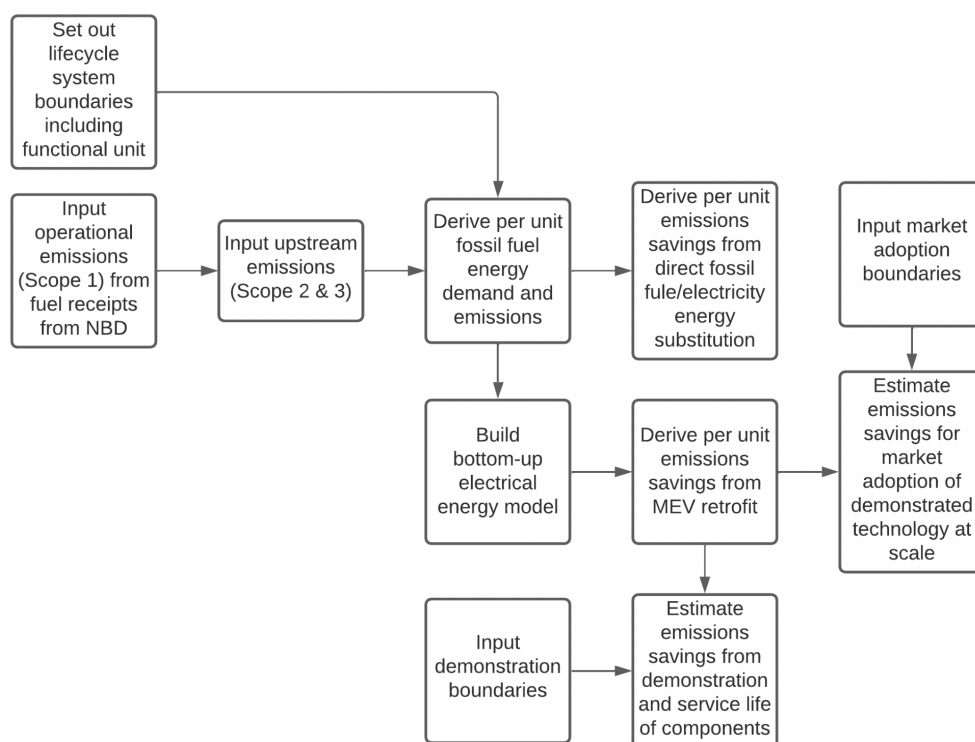

### 7.2.2 Approach to fossil fuel GHG emissions on a per unit basis

We established our per unit basis as ‘kgCO<sub>2</sub>e/cruise night’ because holiday hires are made for 24 hour periods including one night. This distinguishes hire cruisers and other cabin vessels from ‘day boats’. The measure is therefore suitable for making direct comparisons between the demonstration vessel (with certain lifecycle boundaries) and an unconverted (control) vessel.

The boundaries for upstream emissions accounting included:

- Well-to-tank emissions in provision of diesel fuel (Scope 3);
- The batteries as these had the most significant embodied emissions of all the retrofit components (Scope 3);
- The shoreside electrical chargers installed for the demonstration (Scope 3);
- Transmission and Distribution (T&D) losses for delivery of electricity (Scope 3).

The boundaries for operational emissions for the emissions accounting included:

- The emissions from burning diesel fuel (Scope 1);
- The emissions associated with generating UK electricity (Scope 2).

Norfolk Broads Direct (NBD)<sup>58</sup> owns one of the largest hire fleets on the Broads (representing about 9% of holiday and day cruisers) and were able to provide high quality fuel purchase data. The NBD fleet consists of 110 vessels in total of which there are 61 holiday cruisers, sleeping from 2-11 persons, 7 'day cruisers', and 42 'day boats'<sup>59</sup>. The fuel data obtained from NBD refers to the holiday hire cruisers which used gas oil (red diesel) in their diesel engines up until the end of 2018 but then changed to the cleaner Gas-To-Liquid<sup>60</sup> (GTL) fuel from 2019. The vessels are a range of different designs, with the oldest in the fleet built in 1995 and the newest built in 2021. This provides a good representation for other hire operators.

We derived central cases of hire duration and fuel consumption from analysis of NBD fuel receipts and cruise booking data for the hire seasons 2018-20 (although 2020 was adversely affected by covid restrictions)) in order to establish the 'per unit basis'. Energy consumption was used in propulsion and other subsystems dependent on fossil fuels. Our approach involved identification of the central case for cruise duration, estimate fuel consumption and purpose for which it is used, including space and water heating. We then used this to create a baseline from which hire cruiser emissions could be estimated and, as the NBD data is representative of the Broads hire sector, extrapolated it to present a value for the entire hire cruiser fleet serving the Broads.

#### *Central case for cruise duration*

NBD motor cruisers hired for a range of fixed-term holidays over three years of completed seasons, showed the most common holiday length recorded was the 7-night cruise, as shown in Figure 7.3, below.

---

<sup>58</sup> [Norfolk Broads Direct: Norfolk Broads Boating Holidays](https://www.broads.co.uk)<https://www.broads.co.uk>

<sup>59</sup> A 'day cruiser' is classified by the Broads Authority as a vessel with cooking facilities that returns to base each day. A 'day boat' has no onboard cooking facilities.

<sup>60</sup> <https://www.shell.com/business-customers/commercial-fuels/shell-gtl-fuel.html>

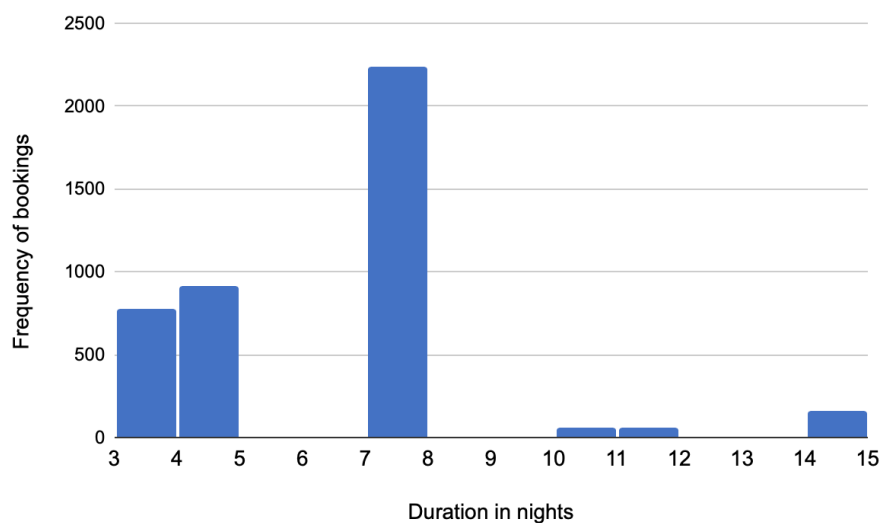
**Figure 7.3. NBD holiday durations 2018-2020**

We therefore selected the 7-night cruise as the central case for cruise duration from which to derive emissions estimates and also energy demand calculations used to specify the onboard battery system in the proposed retrofit demonstration vessel.

From NBD fleet bookings data, the total number of ‘cruise nights’ for the years 2018-2020 are presented in Table 7.3, below.

Booking year	Total nights booked
2018	9987
2019	9390
2020	5906

We will base sales of cruise nights on the 2018 figure of 9,987, out of which 383 cruise nights were sold for hire of the three Fair President vessels owned by NBD. This makes an average of 127.7 cruise nights per vessel per year.

#### *Estimating the central case for fossil fuel demand*

Fuel is used to provide energy for the following key subsystems (see Figure 7.4, below):

- **Propulsion:** Engine to drive the boat propeller and manoeuvring thruster. Efficiency is impacted by the ratio of engine to vessel size and hull shape as well as cruising style.
- **Heating:** Diesel fuel is used to fire a warm air heater for space heating, similar to that used in lorry cabs. Waste heat from the engine is also used to heat hot water via a calorifier, the remaining waste heat is output into the river via indirect water cooling.

- **Ancillary electrical systems and appliances:** When navigating (daylight hours), the electricity is generated from the diesel engine, however users will typically try to access an electricity hook-up point when mooring overnight, which can provide power for these functions.
- **Cooking:** An independent propane LPG system predominates as the main source of onboard cooking energy.

Figure 7.4: Subsystems from a typical Broads holiday cruiser

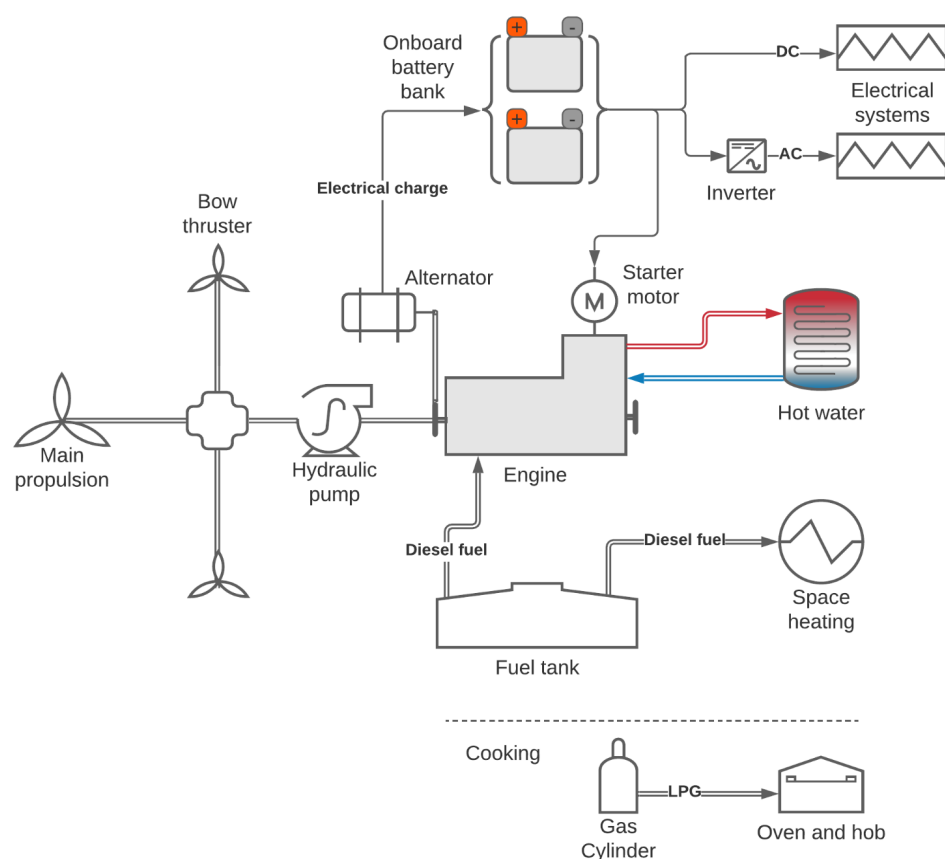

Fuel usage data for 7-night cruises were collected from NBD with the following assumptions:

- Each cruiser fuel tank is filled to capacity after each holiday and the volume required to fill the tank is recorded. That volume of fuel represents the fuel used during the preceding holiday;
- No fuel was leaked, spilled, wasted or stolen;
- Only data for identifiable boats was used;
- Some power will come from 240V shoreside hook-ups, and while this was included in the retrofit energy demand assessment, it does not need to be included in the control vessel emissions assessment as the electricity could have been zero-emission (or will be in future);
- Most Broads cruiser hires take place from around Easter until the end of October;
- Bottled LPG (propane) for cooking is included in the fuel consumption data below based on an annual consumption of 2,160kg/annum (taken from NBD sales receipts, 2021).

We found on average more fuel to be consumed per day for the shorter cruises, because of the interest of customers keen to explore as much of the Broads waterways in the time available within their hire term. Figure 7.5 below, illustrates this point with three histograms representing the frequency distribution of fuel consumption for 3-night, 4-night and 7-night cruises.

While daily and overall energy demand for propulsion varies by length of cruise, the variation in demand to support heating requirements is more closely correlated with the time of year. In the cooler months a higher proportion of fuel use goes towards heating the space and hot water within the vessel. In the peak of summer, we assume that most fuel is used for propulsion and that the demand for hot water and space heating is reduced or withdrawn. The sample below, suggests a 10-11 litre additional requirement in the colder months (Table 7.4).

<b>Table 7.4: NBD boat hire fuel usage by month (2018)</b>									
	<b>Mar18</b>	<b>Apr18</b>	<b>May18</b>	<b>Jun18</b>	<b>Jul18</b>	<b>Aug18</b>	<b>Sep18</b>	<b>Oct18</b>	<b>Monthly Average</b>
Average fuel used (litres)	60.3	54.3	48.44	49.56	49.48	50.75	48.4	54.02	51.90

As well as the use of space heating, we anticipate this is also because engines are less efficient in cold weather and there may be additional requirements for hot water and battery charging.

Figure 7.5: Fuel use for 3, 4 and 7-night hires respectively (2018-2020)

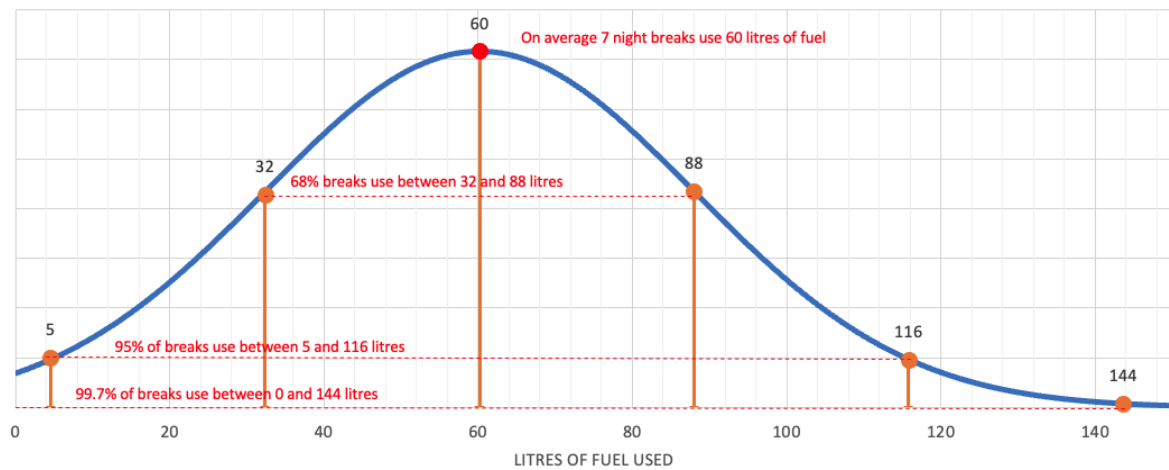
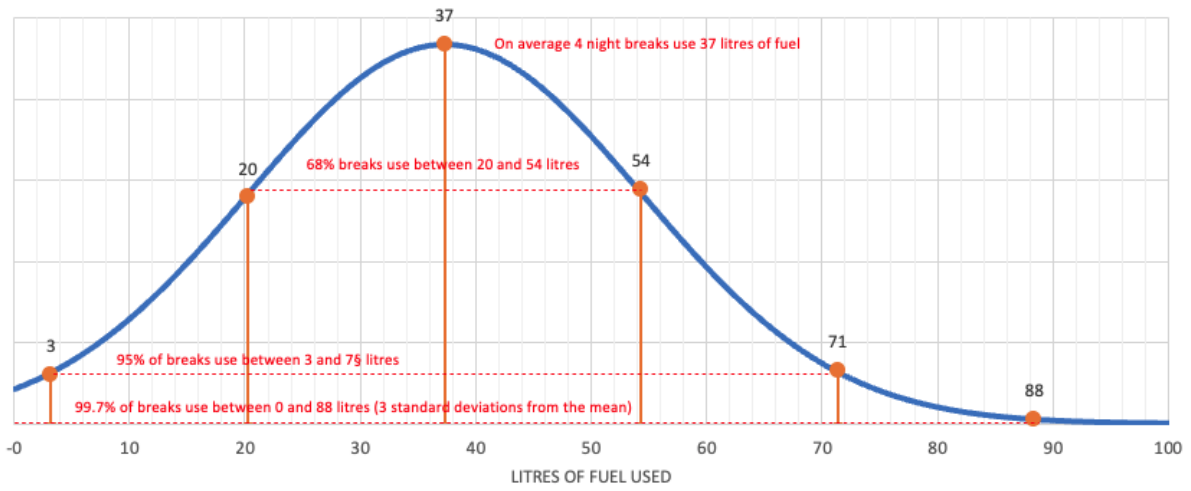
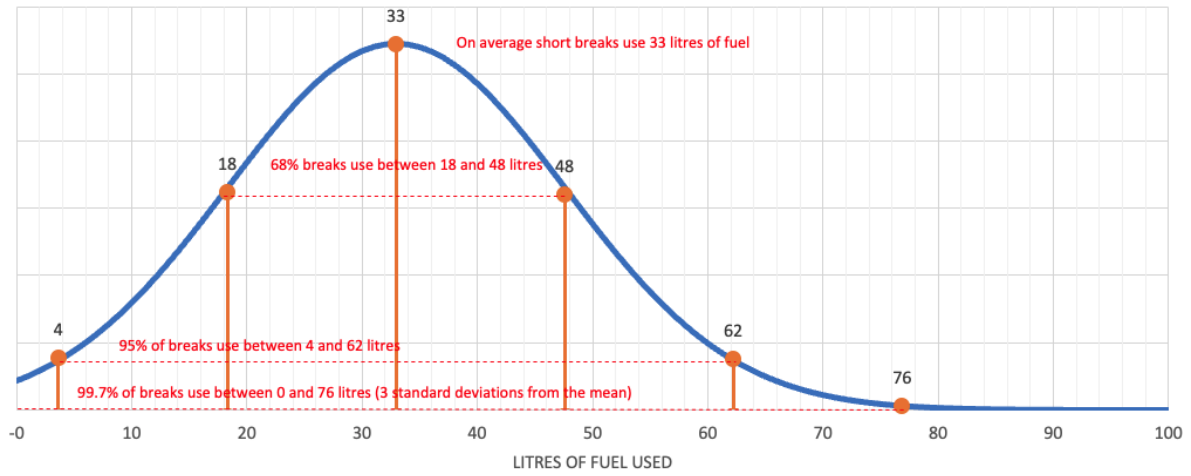

### 7.2.3 Per unit emissions from central case - fossil fuel systems

In Table 7.5 below, we present the combined operational and upstream GHG emissions associated with the recorded total fuel usage for NBD hire cruisers in seasons from 2018 to 2020. Diesel fuel type changed from gas oil (red diesel) to Gas-to-Liquid (GTL) in 2019. Conversions from fuel type to GHG emissions were made, referencing conversion factors produced for Scope 1 and 3 emissions reporting by HM Government for the given years.

NBD total emissions by year were derived according to Formula 1, below.

*Formula 1:*

*Emissions total<sub>year</sub> (operational + upstream) = Total diesel fuel consumed X (Scope 1 + Scope 3 conversion factors) + Total cooking fuel consumed X (Scope 1 + Scope 3 conversion factors)*

Year	Total fuel litres	Fuel type	kg CO <sub>2</sub> e	kg CO <sub>2</sub>	kg CH <sub>4</sub>	kg N <sub>2</sub> O
2018	86,116	Gas oil	317,420	240,931	261	20,960
2019	80,620	GTL diesel	274,247	220,173	28	2,765
2020	51,998	GTL diesel	179,444	144,260	18	1,834

Table 7.6, below, presents the per unit GHG emissions from the NBD hire cruiser fleet, which is representative of the wider Broads hire cruiser fleet. We divided the results from Table 7.5 by the bookings data presented in Table 7.3 for each respective year according to Formula 2, below.

*Formula 2:*

*Per unit emissions (kg GHG/cruise night) = (Operational + Upstream emissions) / Total annual booking nights.*

Year	kg CO <sub>2</sub> e	kg CO <sub>2</sub>	kg CH <sub>4</sub>	kg N <sub>2</sub> O
2018	31.783	24.124	0.026	2.099
2019	29.206	23.448	0.003	0.295
2020	30.383	24.426	0.003	0.311
Averages over all 3 years	30.458	23.999	0.011	0.901

We noted a previous study, in 2008,<sup>61</sup> found an approximate 20% variation in fuel use per boat between boatyards. This could be partly explained by poor data records but also potentially by the parts of the market catered to (“No Frills” vs Luxury), so this margin of error must be considered when evaluating emissions estimates.

We then turned our attention to deriving the estimates for per unit emissions from the proposed demonstration retrofit and shoreside infrastructure installations.

#### 7.2.4 Approach to electrical emissions on a per unit basis

Whatever the specification of retrofit components described in Chapter 5, it was necessary for the purpose of calculating emissions due to the electrified vessel, to estimate the likely electrical energy demand based on an analysis of the fossil fuel usage under normal hire operation. We approached emissions estimates from electrical substitution of fossil fuel systems in two ways. **Firstly**, a crude direct conversion (from the top-down) of energy demand from fossil fuel receipts with a -50% adjustment based on potential inefficiencies described below. **Secondly**, by estimating the in-service (from the bottom-up) energy demand for vessel subsystems upon an electrified vessel.

An estimate of the electrical per unit emissions can be derived by converting the known fossil fuel energy demand and presenting that as electrical energy in kWh, with its associated operational and upstream GHG components. We acknowledge that this approach is subject to error, which is why we will instrument the electrical subsystems in the proposed demonstration to acquire actual electrical energy operational demand data. The results from this approach should therefore be viewed with the following considerations in mind:

- The wasted energy in heat from the marine internal combustion engine (ICE) will be far lower in electrical counterparts (see Figure 7.6, below).
- Electrical motors are known to be more efficient than their ICE counterparts due to the absence of heat lost in exhaust gases.
- When the hot water tank has been fully heated, heat from the ICE is wasted by the engine cooling system. Our proposed instant electric water heating will virtually eliminate wasted energy from water heating.
- Our redesign of the space heating system using electrical infrared heaters will be more efficient in terms of the transfer of heat to vessel occupants, therefore requiring less energy for space heating overall. The insulation of vessel hulls and superstructure would improve efficiency in all cases, but this will be impractical (if not impossible) in a retro-fit demonstration as it would require dismantling all the interior fittings of the vessel.

---

<sup>61</sup> Helen Colyer, 2008, A Carbon Audit of the Broads Hire Boat Industry. University of East Anglia.

**Figure 7.6: Simplified distribution of marine ICE propulsion system losses**

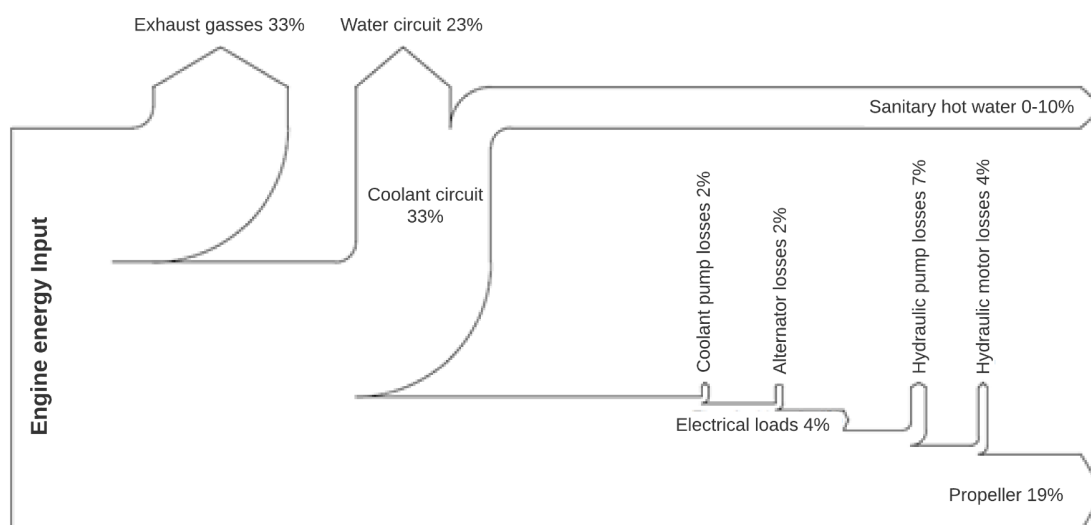

Due to the losses described above, we suggest fossil fuel based vessels may be at least 33% and perhaps, at times, as much as 66% less efficient overall than an electrified vessel.

*Emissions from direct energy demand conversion*

Values derived from UK government conversion factors for fuel properties were used to convert the annual fossil fuel consumption in Table 7.5 to kWh presented for the relevant years in Table 7.7, below.

**Table 7.7: Factors used to convert fossil fuels to kWh**

Year	Fuel type	Conversion factor kWh/litre	Fuel type	Conversion factor kWh/kg
2018	Gas oil	10.10	LPG (Propane)	12.75
2019	GTL diesel	10	LPG (Propane)	12.75
2020	GTL diesel	10	LPG (Propane)	12.75

We then converted the annual fossil fuel consumption presented in Table 7.5 with a nominal 50% deduction for heat losses from the ICE control vessel (see explanation above) and to allow for some on-going heat exchange into the hot water tank. GHG emissions (operational and upstream) from the equivalent amount of electricity consumption (based on 2021 values) are then presented according to Formulas 3 and 4. We set the lifecycle boundary to discount the environmental impact of onboard batteries as this was a like for like comparison based on energy demand. However, the inclusion of the lifecycle emissions due to the shoreside charger was valid as this would be how the electricity would be dispensed to the vessel and so formed part of the upstream emissions component (Table 7.8).

Formula 3:

$Emissions_{electricity} = 0.5 \times \text{Energy consumed} \times \text{Charger LCA operational and upstream emissions}$   
 (includes electricity generated and T&D losses + Charger LCA )

Formula 4:

$Emissions \text{ (not including charger lifecycle)} = 0.5 \times \text{Energy consumed} \times \text{Electricity emissions (electricity generated + electricity T\&D losses)}$

Results of 1:0.5 conversions are presented in Table 7.8, below.

Year	50% equivalent to fossil fuel receipts in kWh	Electrical lifecycle emissions including charger kg CO <sub>2</sub> e	Electrical lifecycle emissions not including charger			
			kg CO <sub>2</sub> e	kg CO <sub>2</sub>	kg CH <sub>4</sub>	kg N <sub>2</sub> O
2018	448,762	225,919	103,718	102,659	390	669
2019	416,870	209,864	96,347	95,363	363	621
2020	273,760	137,818	63,271	62,625	238	408

The results presented in Table 7.8 should be seen in the context (as explained above) that the equivalent electrical energy will do more work than the same quantity of fossil fuel due to the losses and inefficiencies of the fossil fuel based vessel systems.

In Table 7.9 below, we then calculated the per unit emissions for the values derived in Table 7.8 using the bookings data reported in Table 7.3.

Formula 2:

$\text{Per unit emissions (kg GHG/cruise night)} = (\text{Operational} + \text{Upstream emissions}) / \text{Total annual booking nights}$ .

Year	Electrical lifecycle emissions including charger kg CO <sub>2</sub> e	Electrical lifecycle emissions not including charger			
		kg CO <sub>2</sub> e	kg CO <sub>2</sub>	kg CH <sub>4</sub>	kg N <sub>2</sub> O
2018	22.621	10.385	10.279	0.039	0.067
2019	22.350	10.261	10.156	0.039	0.066
2020	23.335	10.713	10.604	0.040	0.069
Averages over all 3 years	22.486	10.323	10.218	0.039	0.067

As per-unit emissions are sensitive to the number of booking nights, which explains the rise in the 2020 outcome above, we have taken an average across all three years to be more representative.

#### *Emissions from estimated in-service electrical energy demand*

In the proposed demonstration we will substitute fossil fuel dependent systems for electrical systems as summarised in Figure 7.7, below.

**Figure 7.7: Schematic showing principal electrical systems replacing fossil fuel dependent systems**

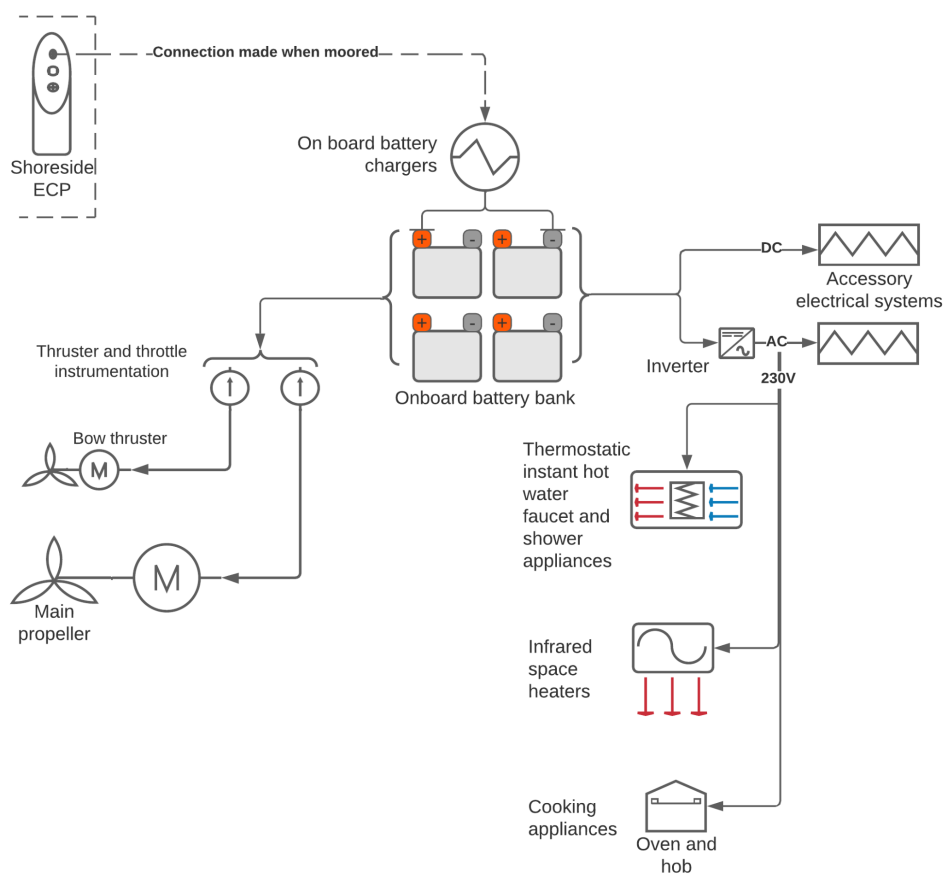

In [Appendix 3](#), the second estimation of electrical energy demand from vessel subsystems was made, accounting for energy required to deliver propulsion, water and space heating as well as cooking and ancillary appliances. We estimated a reasonable combined daily electrical energy demand for a crew of 6 people was 60kWh/day. It should be noted that booked occupancy is not always at vessel capacity and that this figure is more representative of the colder times in the hire season (shoulder periods around Easter and late autumn) than during the warmer summer months. As space heating is a major component of the total daily energy demand on the vessel, we can expect the total

demand to decline at other times of the annual booking season to perhaps as low as 40kWh/day. In Table 7.10, below, we present a range of energy demand anticipated for colder and warmer ambient conditions.

	<b>Colder ambient conditions</b>		<b>Warmer ambient conditions</b>	
<b>Subsystem</b>	<b>kWh/day</b>	<b>Proportion of Total</b>	<b>kWh/day</b>	<b>Proportion of Total</b>
Propulsion	37.3	62.17%	37.3	83.45%
Hot water	2.9	4.83%	2	4.47%
Space heating	15.4	25.67%	1	2.24%
Cooking	2.5	4.17%	2.5	5.59%
Ancillary	1.9	3.17%	1.9	4.25%
<b>Total</b>	<b>60</b>		<b>44.7</b>	

To derive the per unit emissions for the results in Table 7.10, because we are not making a direct energy comparison with fossil fuel demand we assumed the main onboard battery bank in the demonstration vessel and a shoreside 22kW AC to be an integral part of the electrified vessel systems. Therefore, in the life cycle analysis below, we include upstream emissions from the proposed Torqeedo (Boat 1) solution incorporating two BMWi3 Li-ion batteries (rated at 42.2kWh and weighing 284kg each) and a 22kV AC shoreside fast charger together with the dispensed electricity with associated generation and T&D losses.

Lifecycle emissions for the charger are scaled to kWh of electricity dispensed but the assumed life of the charger is ten years according to the LCA data source (Kabus, 2017). The BMWi3 batteries making up the onboard battery bank are warranted by Torqeedo for 9 years. We therefore amortised the upstream emissions values for the shoreside charging equipment and battery over a 10 year anticipated life expectancy before adding the emissions associated with a daily energy demand. We set the cruise nights at 127.7 because this represents a boundary reflecting the proposed demonstration vessel bookings as defined in Section 7.2.2, above.

*Formula 5:*

*Amortised 22kW AC charger upstream emissions = {Charger upstream emissions (cabinet, power electronics and infrastructure emissions) / (10 \* 127.7)} X Daily energy demand*

Amortised 22kW AC charger upstream emissions (kgCO<sub>2</sub>e/day) = 0.000213 X daily energy demand

*Formula 6:*

*Amortised battery upstream emissions (kgCO<sub>2</sub>e/day) = (13,297) / average cruise nights (demo vessel only) in ten years*

Amortised battery emissions = 4,726 / (127.7 \* 10) = 3.3 kgCO<sub>2</sub>e/day

Per unit emissions values were then calculated from the total daily energy demand estimates (colder and warmer) in Table 7.10 according to Formula 7, and the results are presented in Table 7.11, below.

*Formula 7:*

*Per unit emissions<sub>electricity</sub> = Energy consumed per day X (Amortised charger upstream emissions + electricity generation and T&D emissions) + Battery bank upstream emissions (amortised)*

**Table 7.11: Per unit emissions based on electrical demand estimations over cold and warm conditions**

Daily total demand kWh	Lifecycle emissions from charger and battery (amortised) kg CO <sub>2</sub> e/cruise night
60	17.58
44.7	14.04

### 7.2.5 Per unit lifecycle emissions savings

Table 7.12 presents the per unit emissions estimations from the three approaches addressed in the analysis above. The diesel-engined control vessel emissions (column 1) are shown to be higher than making a direct comparison in energy terms with electricity (column 2), because upstream electricity emissions are far lower than diesel fuel. The last two columns present the results of bottom-up estimates of energy demand for the demonstration vessel under cold and warm ambient conditions. The space heating demand is a large variable in this calculation (as shown in Table 7.10).

**Table 7.12: Summary of per unit emissions savings delivered by MEV demonstration kgCO<sub>2</sub>e/day**

Context	Diesel fuel consumption (control vessel)	Electricity equivalent to diesel (includes charger)	Demonstration vessel cold conditions (includes charger and battery)	Demonstration vessel warm conditions (includes battery and charger)
Per unit emissions for a Broads higher cruiser based on NBD data (kg CO <sub>2</sub> e/cruise night)	30.46	22.49	17.58	14.04
Per unit savings over control vessel (kg CO <sub>2</sub> e/cruise night)	0	7.97	12.88	16.42

Per unit emissions savings as a percentage of control vessel emissions		26%	42%	54%
--	--	-----	-----	-----

From the results presented in Table 7.12, we can conclude that the ETB demonstration will offer between 40% and 55% improvement on lifecycle emissions (as defined within the system boundaries described above) over comparable ICE powered hire cruisers (as the control vessel). The reason for the relatively lower ‘electricity only’ emissions improvement in column 3, is explained by the method of calculation, which is simply substituting diesel fuel for electricity and so ignores the inherent efficiency improvements from subsystem electrification built into the calculations in columns 4 and 5. However, these values could also be improved dramatically if the upstream emissions footprint of the battery bank were to be reduced, such as through local (UK) manufacture and sourcing of its constituents.

### 7.2.6 Estimation of emissions savings over the life of the proposed demonstration project and service life of critical components

Estimation of the CO<sub>2</sub>e emissions savings over the span of the demonstration project detailed in Chapter 5 now follows. We calculated this using the results for the contexts in columns 4 and 5 in Table 7.12 (fully electric retrofit, cold and warm ambient conditions) multiplied by the estimated number of ‘cruise nights’ sold for the demonstration vessel in a typical cruise year (127.7 cruise nights).

The results are presented in Table 7.13, but also extend for 5 and 10 years to give an impression of the impact one retrofitted vessel could make over the assumed lifespan of the battery pack and shoreside charger because these offer a guide to large component replacement. At these times we believe there will be an option to replace the electrical equipment, source a UK-made battery or potentially upgrade a retrofitted vessel by installing a hydrogen fuel cell energy source instead of batteries. It is also recognised that ICEs will need replacing in 10 to 15 year intervals and these would offer other upgrade opportunities.

The values in Table 7.13 are calculated according to Formula 8 below:

*Formula 8:*

$$Total\ emissions\ savings\ (tCO_2e) = Per\ unit\ emissions\ savings * duration\ in\ years\ (at\ 127.7\ cruise\ nights\ per\ year\ for\ one\ demonstration\ vessel)$$

**Table 7.13: Emissions savings for duration of demonstration project and equipment lifespan (tCO<sub>2</sub>e)**

Duration years	Cold conditions	Warm conditions
2022-23 (Demonstration period, 1 year)	1.6	2.1
2023-28 (5 years)	8.2	10.5
2023-33 (10 years)	16.4	21.0

### 7.2.7 Approach to estimating operational emissions savings from full technology adoption at scale

Our aim is to show how adoption of MEV technology, such as in the proposed demonstration, if it were to reach the market and be deployed at scale, could impact emissions from boating on the Broads by 2050. Most of the components in terms of the shoreside charging and powertrain already exist but there are technical challenges in scaling and integrating these to the variety of vessel types and sizes currently operating ICEs, which the learning from the approach described in Chapter 5 will alleviate. We made two projections, firstly for the holiday hire sector and secondly for the wider Broads fleet.

All vessels on the Broads are required to pay a toll to the Broads Authority. Licensing data belonging to the Broads Authority breaks down vessels by size and fuel type as shown in Table 7.14, below. As of June 2021, there were 8,056 powered vessels on the Broads, of which 6253 were classed as motor cruisers (this figure includes 'other motor boats').

Vessel type	Hire fleet	% Total hire fleet	Total number of BA registered vessels	% Total number of BA registered motor vessels
Motor Cruisers	733	71	6048	75
Auxiliary Yacht	39	4	1028	13
Day Boat	260	25	775	10
Other motor boats*			205	2
<b>Total</b>	<b>1032</b>	<b>100</b>	<b>8056</b>	<b>100</b>

\*Made up of Workboats, Safety boats, Passenger boats and Exempt vessels.

The private boats on the Broads range in size from dinghies with 5hp/3.7kW engines to large ocean-going motor boats with 600hp/447kW engines (holiday hire cruiser engines average about 54hp/40kW). Some private boats are 'continuous cruisers', moving about the network on a daily basis, whilst some may see only a few days use in any given year. The lack of licensing data on engine size, age, ICE fuel type and usage, and regularity in use of privately owned vessels means that it is difficult to estimate an average fuel use per year for that class. Data on boat movements is only

collected by the Broads Authority during the summer peak to assess the point of highest “stress” on the river and moorings network, and is not necessarily representative of use over the entire year.

It is unlikely that all the ICE motor vessels registered in Table 7.14 (above) will see conversion or replacement by clean maritime systems, as proposed in the demonstration project. This is principally due to the following constraints:

- Investment currently required to convert or purchase purpose built MEVs.
- The increasing number of options to transition using ‘clean’ alternative or synthetic hydrocarbon fuels while retaining existing onboard systems.
- Limited capacity in local or regional boatyards to convert existing vessels or manufacture new MEVs.
- Potential grid constraints for building sufficient shoreside battery charging infrastructure.

These issues are addressed in more detail in Chapter 9 but they point to the focus of the following analysis being upon the holiday hire fleet. Holiday hire cruisers represent the most heavily used vessels on the Broads and are also the sector most invested in transitioning to clean energy systems in order to remain sustainable businesses in future years. As the hire companies are therefore likely to be leaders in MEV technology adoption we will derive an estimate of the emissions displacement from an adoption trajectory described above.

In order to model the GHG emissions savings from the Broads fleet we applied an established innovation diffusion model (after Everett Rogers<sup>62</sup>), to represent adoption of MEV vessels in the transition from fossil fuel to electric marine vessels (see Figure 7.8, below).

**Figure 7.8: Everett Rogers’ diffusion of innovation model**

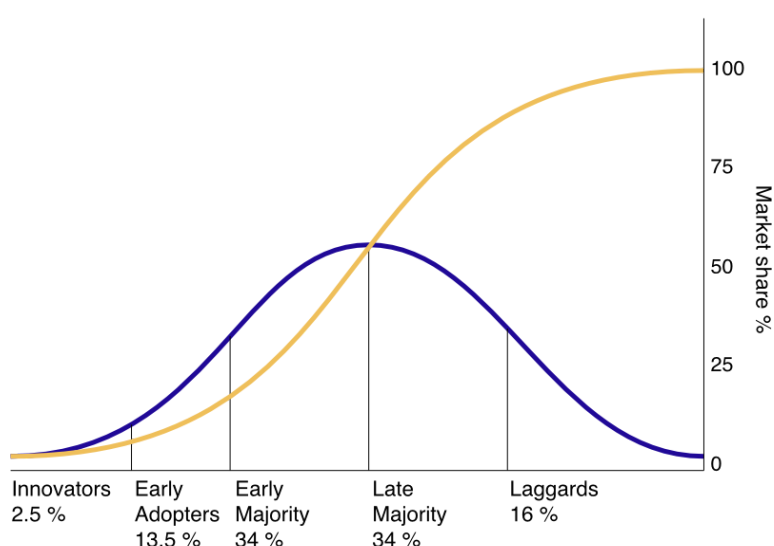

<sup>62</sup> Rogers, Everett (16 August 2003). [Diffusion of Innovations, 5th Edition](#). Simon and Schuster. ISBN 978-0-7432-5823-4.

The following assumptions were made to model operational conditions:

- The average lifespan of principal technologies (eg. ICEs, batteries and chargers) is 10 years after which they will either be replaced or substituted between 2023 and 2050.
- Beyond 10 years the projection is subject to increased error as the opportunities from lower emissions footprints for batteries (potentially manufactured in the UK) is more likely, thereby reducing our baseline for battery upstream emissions. Alternative suitable energy sources are also likely to be viable, such as hydrogen fuel cells powered by locally made hydrogen. These are discussed further at the end of [Appendix 5](#).
- We assume there will be sufficient capacity in the electrical network to support the energy demand from an increasing number of chargers. This could require the use of DERs (such as PV solar arrays, wind turbines and run-of-river micro hydro turbines) where they are required to augment or substitute for electrical network connection constraints.
- We assume there will be a need for a mix of 50kW Rapid DC chargers and 22kW and 7kW Fast AC chargers as the MEV fleet increases. Rapid chargers will mostly be located at boatyards due to the need to turn several vessels around between hires, and where grid connections are also likely to be more resilient to increased energy demand for charging. [Appendix 6](#) describes the use cases for different charger types and [Appendix 7](#) discusses the location of chargers determined to serve the proposed demonstration.
- DERs such as shoreside batteries may also play a role in helping to facilitate bi-directional charging that would also support the opportunity to deliver MEV-grid network services (see end of [Appendix 5](#)).
- Some opportunities may exist for dual function chargers where positioning is possible to serve EVs as well as MEVs.
- We start the projection from 2023 to align with the start of the operational year in the proposed demonstration.

In Table 7.15 below, we present a projection of the adoption of MEV technologies by the Broads hire fleet.

<b>Year</b>	<b>Hire fleet MEVs</b>	<b>MEV adoption by hire vessels per year</b>
2023	1	1
2024	3	2
2025	6	3
2026	10	4
2027	14	5

2028	20	5
2029	26	7
2030	35	9
2031	48	12
2032	67	20
2033	95	28
2034	136	40
2035	193	57
2036	263	70
2037	336	74
2038	409	73
2039	476	67
2040	535	59
2041	585	50
2042	628	43
2043	663	34
2044	688	26
2045	707	18
2046	718	11
2047	725	7
2048	729	4
2049	731	2
2050	733	2

Figure. 7.9 below, plots the rate of adoption and numbers of vessels adopting MEV technologies from the data in Table 7.15. The projection deliberately shows a longer tail in the early years of MEV adoption as skills and infrastructure to support recharging are developed alongside capacity to retrofit existing ICE holiday hire cruisers and/or build new MEVs in line with inventory retirement schedules. It also reflects the increased pressure upon boat owners to adapt to the wider policy environment by adopting MEV technologies. Shortages of spare parts and reduced fuel availability for diesel engines could start to appear in the early 2030's due to their phasing out in the automotive industry.

Figure 7.9: MEV adoption by Broads hire fleet

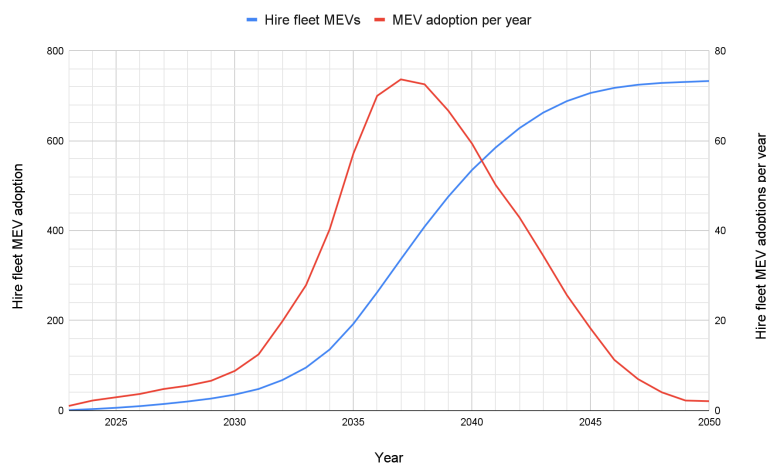

### 7.2.6 Estimation of emissions saved from holiday hire sector

MEV adoption at scale is projected to 2050, although by 2030 there is likely to not only be a change in the overall fleet size but also an increased number of clean maritime energy options to choose from, including hydrogen and synthetic fuels as mentioned above. Interventions of this kind would distort the 'full adoption' estimates of emissions savings about to be made.

Reinforcement of shoreside charger infrastructure, including a range of charger capacities, will be required to support the full adoption of hire cruiser MEV technologies. Because our estimate of emissions savings is based on the 'cruise night' functional unit (which includes a 22kW charger upstream emissions), this approach over-accounts for upstream emissions due to the functional unit being derived from the proposed demonstration with only one vessel (ie. in the estimates below we will see more charger upstream emissions due to the multiplication of the function unit). However, as the overall impact of multiple charger upstream emissions is relatively minor (and will decrease with locally made components) compared to the emissions contributions from the operational electricity dispensed in its use phase, we will ignore this error.<sup>63</sup>

While 9,980 cruise nights were sold by NBD in 2018, we adopted the same value per vessel of 127.7/year corresponding to our demonstration vessel and applied this to the number of vessels adopting MEV technologies in our projection in Table 7.15 to calculate the potential savings across hire sector emissions. We also took the per cruise night emissions savings estimates in Table 7.12, (12.9 kgCO<sub>2</sub>e/day in cold conditions and 16.4 kgCO<sub>2</sub>e/day in warm conditions) as a representative value for the Broads hire fleet as a whole.

Formula 8, below, describes the estimation of emissions savings using the above baselines, if the holiday hire sector were to fully adopt MEV technologies.

<sup>63</sup> Functional units (kgCO<sub>2</sub>e/cruise night) derived for the proposed demonstration which involved one converted vessel and one 22kW charger. Upstream emissions for the charger are estimated at 0.000213 kgCO<sub>2</sub>e/day when amortised over 10 years (the anticipated lifespan of the EVCE).

Formula 8:

*Emissions saved from the Broads hire sector (tCO<sub>2</sub>e/annum) = Number of cruise nights per annum \* per day emissions savings \* annual number of MEVs*

In Table 7.16 below, we show annual and total emissions savings for the rollout of MEVs across the Broads hire sector. Subject to the considerations described above, converting these vessels to clean energy could potentially remove about 7.5 ktCO<sub>2</sub>e to 12 ktCO<sub>2</sub>e from the ICE powered holiday hire sector by 2050.

**Table 7.16: Emissions savings from Broads hire fleet MEV adoption**

Year	ICE fleet number	Emissions savings tCO <sub>2</sub> e/year	
		Cold conditions	Warm conditions
2023	732	1	2
2024	730	5	6
2025	727	10	12
2026	723	16	20
2027	719	24	30
2028	713	33	41
2029	707	43	55
2030	698	58	74
2031	685	78	100
2032	666	111	141
2033	638	157	200
2034	597	223	284
2035	540	317	404
2036	470	432	551
2037	397	553	705
2038	324	673	857
2039	257	782	997
2040	198	880	1,122
2041	148	962	1,227
2042	105	1,033	1,317
2043	70	1,090	1,389
2044	45	1,132	1,443
2045	26	1,162	1,481

2046	15	1,180	1,505
2047	8	1,192	1,519
2048	4	1,198	1,528
2049	2	1,202	1,532
2050	0	1,205	1,537
	<b>Total</b>	<b>15,750</b>	<b>20,080</b>

### 7.2.7 Estimation of emissions displaced from the wider Broads fleet

This approach must be viewed with respect to the aforementioned caveats to adoption of MEV technologies and other clean fuels generally, including cost, varying ages, sizes, usage and boatyard capacity to convert or build new vessels. Our estimates and proposed demonstration focus on hire sector vessels and are therefore not representative of the wide cross-section of registered motor vessels on the Broads. Because of this and to eliminate the problem of estimating emissions from the bottom-up using vessel power ratings (due to the lack of detail in licensing data), we surveyed all the vendors of diesel, GTL and petrol fuel supplied from boatyards on the Broads in 2021. Using their fuel receipts we then estimated the potential CO<sub>2</sub>e emissions savings from the entire number of registered ICE vessels in the Broads fleet.

Table 7.17, below, presents the overall Scope 2 and 3 (operational and upstream) emissions picture from ICE-powered vessels on the Broads in 2021.

<b>Fuel sold (litres)</b>	<b>Quantity (litres)</b>	<b>t CO<sub>2</sub>e</b>
Diesel (Gas oil)	890,156	3,019
GTL (100% mineral diesel)	661,802	2,207
Petrol	2,200	6
<b>Total</b>	<b>1,554,158</b>	<b>5,232</b>

The results indicate that the impact of modifying the hire sector alone to clean energy technologies (from data in Table 7.16) could be equivalent to modifying up to 18% (20,080/115,098) of the entire Broads fleet of ICE vessels (8,056) by 2050. As the hire sector represents only 9% (733/8056) of the Broads fleet, this suggests prioritising this sector for conversion to clean energy systems such as MEVs is justified by at 2:1 weighting. This would be further justified from an emissions perspective if the upstream emissions footprint of the electricity source (the current electricity generation mix and

the battery bank) were reduced. Running the charging infrastructure on offshore wind energy generated in the southern North Sea, or land based wind turbines connected within the area of Broads electricity network could significantly improve the possible emissions savings. However, it is likely for battery electric systems that the GHG content of charging electricity will reduce as a greater proportion of renewable generation is connected to the wider electricity system anyway.

In Table 7.18 below, we present projections of the emissions displaced by removing the use of fossil fuels from 2023 based on apportioning fuel sales in 2021 (see Table 7.17). The savings would require the Broads fleet to be converted without discriminating between the differing vessel types or sectors, i.e. no matter what the vessel, the impact is derived from stopping the use of fossil fuels. This is a best estimate, because as we have shown above for the hire sector, there is still an emissions footprint associated with the implementation of clean energy systems on inland waterways vessels and so this will need to be deducted from the benefit of simply stopping the burning of fossil fuels.

Percentage conversion to clean energy	Number of converted vessels	Emissions saved/annum tCO <sub>2</sub> e/yr	Emissions saved by target date tCO <sub>2</sub> e				
			2025	2030	2035	2040	2050
5%	403	262	523	1,831	3,139	4,447	5,755
10%	806	523	1,046	3,662	6,278	8,894	11,510
15%	1,208	785	1,570	5,493	9,417	13,341	17,265
20%	1,611	1,046	2,093	7,324	12,556	17,788	23,020
25%	2,014	1,308	2,616	9,155	15,695	22,235	28,774
30%	2,417	1,570	3,139	10,987	18,834	26,682	34,529
35%	2,820	1,831	3,662	12,818	21,973	31,129	40,284
40%	3,222	2,093	4,185	14,649	25,112	35,576	46,039
45%	3,625	2,354	4,709	16,480	28,251	40,023	51,794
50%	4,028	2,616	5,232	18,311	31,390	44,470	57,549
55%	4,431	2,877	5,755	20,142	34,529	48,916	63,304
60%	4,834	3,139	6,278	21,973	37,668	53,363	69,059
65%	5,236	3,401	6,801	23,804	40,807	57,810	74,813
70%	5,639	3,662	7,324	25,635	43,946	62,257	80,568
75%	6,042	3,924	7,848	27,466	47,085	66,704	86,323
80%	6,445	4,185	8,371	29,298	50,224	71,151	92,078
85%	6,848	4,447	8,894	31,129	53,363	75,598	97,833
90%	7,250	4,709	9,417	32,960	56,502	80,045	103,588
95%	7,653	4,970	9,940	34,791	59,641	84,492	109,343
100%	8,056	5,232	10,463	36,622	62,780	88,939	115,098



## 8. ECONOMIC IMPACTS

In this section we address the economy of the Broads marine sector and its impacts on the wider economy both present and in future MEV rollout, following the pathfinding anticipated as a result of this feasibility study and the proposed demonstration.

### 8.1 Overview of economic context for the Broads

Approximately 6,000 people live within the executive area of the Broads, and the local economy is heavily dependent upon tourism. Pubs, restaurants, cafés, museums, shops and art galleries all depend upon a thriving Broads tourism offering to make a living and to provide employment. Nature reserves within the Broads rely on visitors for their income, and there are numerous attractions, some of which receive over 100,000 visitors a year.

Tourism is the largest sector industry in Norfolk, supporting 69,266 jobs (19.5% of all employment) and contributing £3.423 billion to the local economy.<sup>64</sup>

The relationship is in many ways symbiotic - not only do riverside and village facilities require tourists to keep them sustainable, but the hire boat industry in particular relies upon the existence of those facilities as part of the holiday experience. Boating visitors need places to stop and eat, to replenish supplies, and to entertain themselves.

Likewise, hire boat operators (and indeed the wider private boating network) rely on the presence of competing boatyards and servicing centres throughout the Broads to provide moorings and facilities for their customers, in order for the Broads to function as a holiday destination.

Due to the nature of providing hire vessels, the boat hire industry also supports other industry sectors, including; marine engineering, tow/tug boat services, diving and recovery services and boat builders. Alongside these services are several micro and SMEs businesses that provide bespoke components for hire cruisers such as upholsterers, cover makers, window manufacturers and chandlers. Without the boat hire industry, many of the SMEs above could become unviable.

### 8.2 Potential impact on jobs

We do not comment here on the potential to generate additional jobs in the Broads area, but rather restrict our estimates to impacts on jobs across boat yards directly relating to the transition of boats to new technology. The baseline assumes the same number of cruisers (circa 720) will be active in the Broads overall.

The job impact resulting from the demonstrator project is minimal as the project has been designed to simulate “business as usual” activities as closely as possible; that is to say undertaking retrofit work in the winter months and trialling the boat with live customers during the peak holiday season.

---

<sup>64</sup> <https://www.visitnorfolk.co.uk/wp-content/uploads/2021/11/Economic-Impact-of-Tourism-Norfolk-Report-2019.pdf>

In the longer term, the impact on jobs corresponds with the impacts on the boat yards. There are around 20 boat yards offering holiday hires, although only 5 have fleet sizes over 40 boats. There is an established network of boat builders (some independent, some in-house at the larger boat yards) that maintain these hire cruisers and bring between 2 and 8 new boats to the fleet in a given year.

Once in service, boats will be brought in for maintenance and cosmetic repairs as required. A programme of regular retrofitting over the winter months ensures that the older, but still serviceable, vessels are repaired and refreshed ahead of the next hire season. An engineer and assistant can undertake a complete overhaul of 3 boats in the winter months, so given typical staffing levels, the larger boat yards can retrofit 5 or 6 boats in the offseason.

If the speed of electric boat conversion were to mirror these retrofitting schedules, the net change in jobs would be negligible. Only in a scenario whereby the electrification of hire cruisers is accelerated (either through financial incentives or legislation) would the overall number of jobs change. For example, if we assume a static cruiser fleet of 720 boats and up to 25 are retrofitted each winter, a complete conversion would occur in 2046, just ahead of the Net Zero target.

We can speculate on three potential alternative scenarios:

- If a target date of 2035 is desired (and policy in place to support that), 55 boats would need to be retrofitted each winter, resulting in at least 24 new high-skill jobs between 2022 and 2035, with some retained beyond this timeframe
- If we assume the non-linear conversion rates as presented in Table 7.15, the window for additional jobs is 2034 to 2043, and at peak (2037-38) an additional 49 jobs are created
- Based on our understanding that retrofit conversions are currently cost prohibitive without UKRI funding, we have to assume that the conversion of boats will only begin in earnest when there are appropriate funding streams, battery cost curves come down, and/or legislation is in place. If we suppose in a worst case scenario that these conditions only align from 2040 onwards, an additional 58 jobs could be required to ensure complete conversion before 2050. Given that this leaves a compressed time frame, it also introduces a significant risk that some retrofitting activity will be outsourced to non-local boat yards, as only so many can be out of the water at one time.

Equally, the impact on jobs could be more complex than simply employment figures alone. The boating industry is reliant on skills from long standing local specialists. The sector is not currently attracting new talent, but the introduction of new technology and development opportunities could attract a new wave of apprentice and junior boat builders that would ensure the relevant skills are retained locally. Nearby colleges are focused on offering skills relevant to the Net Zero transition and electric vessel maintenance could be proposed as a module / work experience opportunity.

Given the high dependency on tourism, the boat hire companies generate a disproportionately higher level of employment - with a greater skill-base - than typical holiday accommodation such as self-catering accommodation or hotels. In addition to the usual job roles of cleaning, reception, booking, maintenance, and management required by accommodation providers, boat hire operators also provide jobs in marine engineering, manufacturing and servicing. Due to the in-depth

knowledge required at the booking and management stages it is also more common for full time positions and long-term employment to be found in the industry when compared with more traditional accommodation providers.

### **JOBS SUMMARY**

**Demonstrator Impacts:** The jobs growth attributable to the demonstrator is negligible as existing staff will be utilised, perhaps with supervision from component providers in the first instance.

**Longer-Term:** Job growth at boat yards depends on the funding and policy mechanisms to support widespread boat conversion. If there are early interventions to support a transition, 20-30 new high-skill jobs could be created. If conditions mean action is limited until 2040, there could be significantly more jobs (50-60) created, but the chances of these jobs remaining with local companies are significantly reduced.

## 8.3 Potential impact on Gross Value Added to the local economy

### 8.3.1 Tourism

The *Economic Impact of Tourism 2019* report by Visit Norfolk estimates staying visitors accounted for £878.2m income into the local economy in Norfolk. As 2% of visitors are staying at “Boating moorings”, it is expected that boating would also account for circa 2% of the income generated by overnight visitors to the local economy, or around £17.6m.<sup>65</sup>

<b>Sector</b>	<b>Revenue</b>
Accommodation	£246.4m
Retail	£96.6m
Catering	£209.2m
Attractions	£73.8m
Transport	£80.0m
Other 'non-trip' spend	£172.2m
<b>TOTAL</b>	<b>£878.2m</b>
<i>Deduced share of Broads cruiser hire fleet (2%)</i>	<i>£17.6mn</i>

Since 2019, demand for boating holidays has increased due to the burgeoning demand for staycations during the Covid-19 pandemic. Assuming that the experience of Norfolk Broads Direct is representative of the wider market, bookings are up 19.4% (2021 vs 2019) in occupancy, with total occupancy for the available season at 91% in 2021, compared to 71% in 2019. There is opportunity

<sup>65</sup> <https://www.visitnorfolk.co.uk/wp-content/uploads/2021/11/Economic-Impact-of-Tourism-Norfolk-Report-2019.pdf>

for growth and expansion to meet this demand, which has the potential to bring further income to the local economy and more jobs. 2022 is also set to be a record year, with advance bookings far ahead of previous years.

Evaluating the economic benefit of electrification on the tourism sector is a two-prong consideration; firstly protecting existing tourism revenues and secondly, growing revenues in the sector.

The priority focus is to ensure that any activities to electrify the hire cruiser fleet are carried out in a way that **safeguards current levels of tourism and the circa £17.6mn of associated revenue generation**. There are two drivers at play: ensuring that the fleet stays ahead of legislation to decarbonise the sector to ensure that maximum tourist capacity can be maintained, and that the visitor experience is maintained so that high levels of loyal repeat business are preserved.

Surveys conducted by Norfolk Broads Direct and the Broads Authority (see Appendices 1 and 2) revealed that 93% of respondents answered 'yes' or 'maybe' when asked if they would hire an electric boat, with 10% citing quieter travel as the main motivator, but there were significant concerns around the reliability and convenience of electric boats and whether adequate charging infrastructure would be available.

While the majority supported the transition to battery-electric vessels, only 9% of respondents to the Norfolk Broads Direct customer survey responded that they would be willing to pay more for an electric boat. If this were reflective of all consumer attitudes, we would have to assume no net increase in GVA for the hire companies as price-parity with conventional boats would have to be maintained (in the near-term at least.)

For a view of true GVA above the current tourism baseline, we need to estimate how an improved offering with quieter journeys and improved sustainability credentials will attract new tourist demand for hire cruiser holidays. While the Norfolk Broads Direct survey revealed only 9% of respondents would be willing to pay more for an electric boat, this survey was conducted among existing holiday makers and may therefore not capture the views of all future holiday makers.

Various research articles around price elasticity of demand for sustainable products and services have noted a recent surge in willingness to pay more for environmentally-conscious offerings. Values vary significantly by source and sector, but positive responses over 60% are becoming common. There is also a strong trend for younger age groups and more affluent households being prepared to pay a premium. With this in mind, we would recommend a future survey which seeks to capture these demographic indicators in some form.

It is highly speculative to estimate an impact on GVA on this anecdotal trend basis, and there will naturally be a cap on the additional value. Without the confidence around the price elasticity, we would have to be highly conservative and suggest an uplift in prices of between 1-5% above diesel equivalents, equivalent to £300,000/year at the upper bound of that range. (Based on 2% market share of the hire fleet in the accommodation and transport spend in Table 8.1)

The GVA potential for the wider tourism sector can only be based on anecdotal examples. For example, if a boat was unable to recharge overnight, holidaymakers may need to set aside time

during the day (potentially 2 hours or more), in which time they could visit or extend time spent at attractions, shops and hospitality venues. This extra time is unlikely to increase spending on big-ticket items such as admission tickets and evening meals, as these will occur either way. The additional value could come from small discretionary spends on snacks, drinks and souvenirs. If we conservatively assume on average an additional £10/week/boat (all boats out in peak season, 40% out in shoulder seasons), over £213,000/year could be added to the local economy.

#### **TOURISM SUMMARY**

**Demonstrator Impacts:** The impacts on tourism GVA from the demonstrator are negligible. The project is intended to operate within business as usual conditions. There is an opportunity to use the trial as a PR or advertising opportunity, particularly if the trial is successful in demonstrating a quieter, cleaner but comparably convenient experience.

**Longer-Term:** The priority in the longer term is to safeguard the existing tourism revenue. It is unclear to what extent consumers will be willing to pay more for the electric holiday option. Initial surveys suggest this is almost nil, but wider market research is more upbeat and, if true, could translate to £300,000/year for the holiday hire sector.

For the wider community GVA, a survey during the demonstrator phase would be valuable. Based on high-level assumptions, £213,000/year in GVA could be generated locally.

### 8.3.2 Supply chains

The impact on local supply chains is limited. The vast majority of components identified in the retrofit demonstration design will be sourced from overseas, including motor drive train components from Europe (Germany). We have specified batteries from a European company, but it is likely that within their supply chain, components will be sourced from a range of global companies, with batteries likely to be produced in Asia (predominantly China).

Unless equivalent manufacturers establish facilities in the UK, the value-add remains negligible from component spend in the longer term. We are aware that investment into so-called gigafactories (such as the BritishVolt plant in Sunderland) will stimulate some level of home-grown supply chain opportunities, but this cannot be quantified until comparative product types and price points are understood compared to the imported equivalents.

UK GVA could instead lie in compiling different components into pre-configured systems ready for fast and efficient retrofit procedures and precalibrated to UK electrical standards. In the demonstrator phase this does not apply, as the retrofit would be a first-of-its-kind procedure and there could be a number of minor component tweaks and layout changes that would make a pre-configured system redundant. Only once a successful demonstration has taken place can a view on streamlining be taken.

Quantifying this potential without engaging with local businesses means that only highly speculative values can be determined. If we assume that a full electrical 'harness' or 'loom' could be produced

with 4 hours labour at a cost of £76 (£15.80 hourly wage plus 20% overheads), the additional GVA is just under £55,000 across full fleet conversion.

If we posit that there are equivalent pre-assembly opportunities for heating systems or vessel monitoring systems, we could raise this estimate to £115,000 over the period 2023-2050. If annualised to compare against our other GVA estimates, this equates to just over £6000/year.

#### **SUPPLY CHAIN SUMMARY**

**Demonstrator Impacts:** The impacts on UK supply chain GVA from the demonstrator are negligible given the reliance on imported products for the most costly components.

**Longer-Term:** Until there is greater clarity on the supply chain alternatives from UK manufacturers, the UK GVA has to be recorded as negligible. The battery costs are the most significant cost element of the retrofit design, so identifying UK-produced alternatives would unlock millions of pounds of GVA over the period 2023-2050 (notwithstanding the international raw materials required to build the battery packs.)

There is potential to secure UK supply-chain GVA through pre-assembled systems. Without the results of the demonstration project, we cannot properly quantify the opportunity. As a bare minimum we can include a ballpark £6,000/year.

## 8.4 Non-tangible benefits

There are a number of non-tangible benefits that can be unlocked by our proposed demonstration project and wider electrification of the hire cruiser fleet. The most profound benefit is the reduction in carbon dioxide emissions, as discussed in Section 7. There are also opportunities to enhance user experience (which in turn could provide justification for passing on additional costs), and to achieve other environmental improvements in a sensitive and nationally-important ecosystem.

### 8.4.1 Charging infrastructure as a public good

This project has been focused on the conversion pathway for the hire cruiser fleet, but there are a wider range of vessels, both private and hired, that will also need access to recharging facilities in the longer term. The issue is that the cost of the charging pillars and connections to the grid are cost prohibitive on an individual basis and only make financial sense (without grant funding) when a large number of boats convert and the costs can be socialised.

Following on from this study and the proposed demonstration project, conversations with the local authorities and the wider boating community on the Broads are needed to discuss charging needs and willingness to act collectively to establish and fund a wide-reaching charging network. The work undertaken in this study gives essential grounding for these discussions, including indicative locations, capacities and costs.

### 8.4.2 Improved water quality

Most of the oil and fuel pollution in our waterways is caused by everyday oil leaks, refuelling spillages and engine exhaust emissions. Electric boats do not require any liquid fuel and very little oil, so they are far less likely to cause harm to wildlife, which is particularly pertinent given the unique characteristics of the Broads and its ability to support endangered and rare species.

Conversion of the vessels to electric propulsion could be combined with other retrofit activities (if not already in place), that would also support improved water quality. This could include closed-loop waste water recycling to reduce the incidence of cleaning chemicals (including phosphates) from entering the water, non-toxic anti-foul paint for hulls and speed limiters to reduce wash. These ideas, and more, form part of the Green Boat Mark programme<sup>66</sup>. In future, fuel type could be included as a credential for awarding this designation to hire companies.

### 8.4.3 Reduced noise pollution

Given that the battery will replace diesel combustion engines, the noise pollution from each vessel can be drastically reduced, both when travelling and when moored up. The World Health Organisation defines noise above 65 decibels (dB) as noise pollution, and less than 30dB is required for good quality sleep. The newer vessels in the fleet, and those with layouts that distance the engine from the living quarters, will likely already fall within this window. However, some boats may be above 65dB, as commercial automotive diesel engines can generate between 70-100dB.

The reduction in noise pollution has two important outcomes – firstly, reducing the negative impact on local wildlife, particularly fish and waterfowl. Studies from around the world have shown that noise pollution can impact both breeding cycles and behaviours.

Secondly, improving the experience of passengers. Prolonged exposure to loud noises can induce stress, irritability and headaches in humans, and many holidaymakers will be using the trip as an opportunity for rest and relaxation. The benefit from noise reduction was considered an attractive reason in favour of electrification by respondents to the Norfolk Broads Direct customer survey (Appendix 2). A perception that an electric vessel offers an improved user experience is key to being able to charge an uplift on sustainable holidays to offset the vessel conversion costs.

### 8.4.4 Improved air quality

The reduction in emissions is discussed in detail in Section 7. Here we refer to air quality from a health and safety perspective. At present, holiday makers may need to run the internal combustion engine when moored up if no electrical hook-up is available. The engine is required to provide power for the domestic appliances, or additional heat in the evenings. With a battery alternative, the exposure to exhaust fumes offers a cleaner and more enjoyable overnight stay.

Removing the combustion engine also removes the risk of carbon monoxide poisoning. Incidents have been known to occur when wind blows exhaust fumes into the cabin of a vessel, or from poorly

---

<sup>66</sup> <https://www.broads-authority.gov.uk/boating/owning-a-boat/environmentally-friendly-boating>

ventilated gas cooking equipment. Whilst the Boat Safety Scheme mandates Carbon Monoxide Detectors, it would be preferable to eliminate the risk at source.

### 8.5 Distribution of benefits by location

In trying to establish the distribution of the additional jobs and GVA discussed in sections 8.2 and 8.3, we can create a baseline distribution for the demonstrator and for the longer-term conversion of the hire fleet. This latter option is highly contingent on market developments outside of our control, ranging from emerging supply chains, timing of funding support and clarity from policy makers. There is therefore considerable margin of error in these distribution breakdowns.

Table 8.2: Summary on distribution of benefits				
		Local or UK	Europe	Global
Demonstrator phase	Jobs	>95%, with majority local	<5%	0%
	Tourism GVA	100%, local	0%	0%
	Supply chain GVA	<5%	>95%	
Longer term	Jobs	100% - local/UK split dependent on timings	0%	0%
	Tourism GVA	100%	0%	0%
	Supply chain GVA	<5%, unless alternative providers identified	>95%	

### 8.6 Economic impacts over time

The economic impact of the demonstrator is recorded in Table 8.3. It shows limited overall impact over the three-year period. We expect to use in-house labour for the conversion, with minor consulting support from component suppliers. We will also conduct the live trials on a cost-neutral basis to ensure that the boats will be hired. It may also be necessary to offer a discount if there is consumer reluctance at the booking stage. As discussed, there will be minor spend with local supply chain providers for components, but the bulk of the equipment spend will be with European companies.

Table 8.3: Economic impacts over time (demonstrator)				
		2022	2023	2024
Demonstrator phase	Jobs	0	0	0

	Tourism GVA	0	0	0
	UK supply chain GVA	<£10,000	<£10,000	0

Undertaking the demonstration will help to solidify equipment, labour and fuel costs to convert cruisers to battery electric, as well as the optimal patterns of charging and off-season maintenance programmes. Equally, it will provide an opportunity for market testing with real consumers. Their views on the comparable holiday experience and post-trip survey will enable us to establish the extent to which an uplift can be charged for a sustainable holiday without jeopardising current tourist numbers and revenues. As such, we would be best placed to comment on the long term impacts following the demonstrator phase.

Furthermore, this study has so far established that at current prices, the retrofitting of vessels is cost-prohibitive without grant support, meaning a wider roll-out is unlikely to immediately follow the demonstration project, unless there were considerable shifts in policy, regulation and/or market costs. As we cannot assume ongoing financial support, the timing and scale of economic impacts being felt will be reliant on a number of factors, including:

- **The extent to which battery costs fall** (both nationally and globally). New processes and economies of scale in production have seen costs fall 89% since 2010<sup>67</sup>, but due to the use of rare earth metals and heavy demand from other sectors, further cost reduction potential may be starting to plateau.
- **The extent to which legislation or local regulations change.** At present there are no formal cut-off dates for new or existing vessels to become zero-emission. Were these to be introduced prior to 2050, the hire companies would be forced to take action. The economic impacts would depend on the timetables given. For example, a far-off date could enable owners to delay conversions, but a date too near could mean having to reduce the number of vessels on the water, jeopardising their revenue and the local tourism GVA.
- **The incentives used to encourage conversion.** Whether incentives are local (toll changes, registration fees, local carbon taxes) or national (grants, tax breaks, low-interest loans), they have potential to rebalance the cost profiles between electric and fossil-fuel vessels. Some measures may not be enough to justify conversion on their own, but taken in the round with other factors, could spur earlier action.
- **The potential change in consumer attitudes and behaviours.** As awareness and messaging around sustainable travel become more embedded, we can expect increased interest in low-carbon 'staycations'. As discussed earlier in this chapter, there is currently limited willingness to pay more for sustainability, but this could change in the longer term.

Given the considerable uncertainties, the economic impacts are included below as high-level ranges only, based on the variations discussed in sections 8.2 and 8.3. We have assumed boats are converted in line with the rates given in Table 7.15 for consistency. The tourism upper bound allows for 5% price elasticity on sustainable holidays and supply chain upper bound assumes that the full

<sup>67</sup><https://about.bnef.com/blog/battery-pack-prices-fall-to-an-average-of-132-kwh-but-rising-commodity-prices-start-to-bite/>

powertrain and battery components can be sourced in the UK from 2023 (irrespective of the probability of this happening). Cost values are rounded to three significant figures.

<b>Table 8.4: Economic impacts over time (longer term)</b>				
		2030	2040	2050
Cumulative economic impact by date milestones	Jobs (additional FTE)	7.2	47.2 Peaks at 59.2 FTE in 2037	1.6 Over 20 FTE additional jobs until 2044, when conversion activities near completion and MEV are BAU
	Tourism GVA (£)	£10,500 - £25,200	£156,000 - £375,000	£213,000 - £513,000
	Supply chain GVA (£)	£8,200 - £3,530,000	£120,000 - £52,500,000	£167,000 - £71,800,000

## 9. BARRIERS TO COMMERCIAL ADOPTION

This Section presents a summary of the barriers to commercial adoption that we have identified in preparing this feasibility study. We have inserted an additional column to the prescribed guidance (from UKRI) in order to display why we believe the proposed demonstration project is justified. The colour-coded column on the left hand side defines the barrier rating as follows:

- Green – adoption would proceed without this but could increase the pace of adoption if addressed
- Yellow – may slow the adoption of the technology
- Red – further projects could not succeed without addressing this barrier

The numbers in the left hand column refer to notes below Table 9.1, expanding on the detail for a particular barrier.

<b>N o t e s</b>	<b>Barrier</b>	<b>Type of barrier</b>	<b>Challenge posed by barrier</b>	<b>How will the proposed demonstration project overcome this barrier?</b>	<b>How will a further demonstration project overcome this barrier?</b>
<b>1</b>	Supply chain	Commercial	Geopolitical and environmental events result in supply chain disruption - for example lead times on some integrated circuits are very advanced	Develop trusted partnerships early and innovate with mutual benefit to project and partner/supplier to secure procurement of essential components	Opportunity to develop more local component solutions through better understanding of technical needs
<b>2</b>	Battery capacity	Technical and commercial	On-board battery capacity limited by high cost and lower energy density than diesel fuel	Monitoring of energy consumption of demonstration vessel will help optimise on-board systems to reduce drain	Refine understanding of operational battery requirements and develop knowledge of flexibility service benefits to DNO
<b>3</b>	Lack of shoreside charging locations at moorings	Geographic and commercial	The transition will fail without the correct balance of charging infrastructure and on-board energy capacity	Develop knowledge of MEV usage patterns and moorings to locate sufficient charger capacity	Add confidence to scale-up of shoreside charging infrastructure with better targeting of ECP locations
<b>4</b>	Insufficient electricity network capacity to support shoreside	Geographical and commercial	The transition will fail if insufficient energy capacity is available to support the	A trial mix of fast (AC) chargers will allow a demonstration vessel to be	Understand where shoreside charging infrastructure needs RET integration to

	charging energy demand		required amount of shoreside charging systems	operated and charging pattern to be understood	augment grid capacity
5	Return on investment unproven	Commercial	Operators will need to be confident of a viable ROI before upgrading hundreds of boats, rather than just diversifying into some other business	Demonstrating that the technology is mature and reliable will help change operator and investor concerns about ROI	Further develop confidence in ROI as more understanding of relationships between costs, MEVs and shoreside charging infrastructure are evidenced
6	High capital cost of retrofit	Commercial	Further projects could not succeed without addressing this barrier	Develop knowledge of potential cost reductions and reduction in design risk	Increase knowledge of the cost reductions that can be realised by scale and reduction in design risk
7	Conservative traditions and reluctance to adopt new technology	Psychological	Operators and private owners must be convinced of the benefits of replacing multiple systems which still work	A successful trial will demonstrate whether there is adequate customer demand for silent and eco-friendly boating holidays	Reinforce visibility of Government lead transition objectives to net zero marine emissions and encourage adoption of MEVs as the new normal
8	Range anxiety	Psychological and commercial	Hire customers and private owners must have confidence that they will not be stranded without power	A demonstration vessel will reveal adequate shoreside charging opportunities that will show that the technology is mature and ready for market	Refine and expand the technology mix to provide further evidence to reduce range anxiety
9	Local skills and facilities shortages to implement the retrofitting of MEVs	Economic and practical	Without new skills development in marine electrical system integration vessel retrofits could be delayed	Develop understanding of the skills required to resolve retrofit issues as well as establish design templates	Build the range of skills required by understanding the retrofit design challenges posed by a wider range of vessels and shoreside infrastructure
10	Physical space to retrofit a vessel designed for with fossil fuel powered systems	Practical and economic	Space, access, insulation and alignment of components must all be reconsidered	Pilot ways to overcome design issues with sourcing of new componentry	Refine and expand solutions to a wider range of vessels

## 9.1 Explanation of barriers to commercial adoption

The following notes are oriented towards the current barriers we believe face the proposed demonstration following-on in Phase 2 from this feasibility study. In many cases, a further demonstration would be appropriate to increase knowledge and design confidence in making this whole-systems transition confidently felt for, not only the Broads, but other inland waterways as well.

1. The current disruption to global supply chains from a succession of significant events impacting on UK trade (including Brexit, climate change impacts upon Chinese parts manufacturers, the Covid pandemic and now the war in Ukraine) potentially present a barrier to project progress without timely delivery of essential components. The proposed demonstration project must therefore be clear in terms of grant approval and start date in order to develop trusted partnerships to enable confident planning and delivery of projects on time until matters beyond our control are resolved.
2. The cost of marine battery systems is high and could increase as the competition for raw materials to make EV batteries increases. Striking a careful balance between the anticipated energy demand and the availability of recharging facilities is therefore critical to optimal price control of the marine transition to clean energy systems. These are two sides of the trilemma described in [Section 5.2](#). The current lack of precise energy consumption data for inland waterways vessels presents a specification challenge which will be addressed by instrumenting and data logging on the demonstration vessel. It will be a data collection test bed to monitor not just total daily energy consumption, but different types of consumption at different times of the year, in order to optimise electrical systems over time.
3. Moorings need to be strategically selected for shoreside chargers to be efficiently located with respect to demand for charger access, and have the capacity to replenish capacity carried in onboard battery banks within a reasonable waiting time. We anticipate the highest demand for charging facilities will be in hire vessel termini where multiple vessels will need to be recharged as part of the turn-around process. However, competition already exists on the waterways for limited moorings with electrical facilities. We will gain insights into the usage patterns of the selected charging locations in the demonstration project, enabling scale-up to proceed with greater confidence.
4. Although electrical infrastructure is already installed in marinas (which tend to be in built-up tourist locations with street lighting, hospitality venues and hire boat operators), the electricity network infrastructure cannot always accommodate higher rated chargers (circa 50kW to 100kW) and sufficient charging options. New installations can be hampered by limited local network capacity for new connections, and the cost of remedial upgrade work to the network being prohibitive. This is even more true of inland waterways which include a high proportion of remote locations, such as in the geography of the Broads. For the demonstration project we will therefore consider the need for network capacity augmentation using renewable energy technologies (RETs) to generate on-site energy, as well as sharing grid connections with existing users. Trialling new funding options to address the expense of installing a scalable shoreside charging infrastructure will also be a key feature of the demonstration project.

5. This barrier is the subject of a 'chicken-and-egg' challenge, as the absence of a proven comparable scenario (apart from road-based EV adoption) makes the ETB demonstration of viability and attractiveness to investment in the transition to net zero, critical. In turn, this attractiveness is based on return on investment that depends on customer behaviour in the hire sector and possibly a prevailing ecological psychology in both hire and private sectors. A single hire cruiser demonstration project cannot also be expected to answer this question across the board, but in addition to the demand for electric day boats, it will help to inform and potentially pathfind solutions to a scale-up that creates a healthy return on investment.

6. Given that the expected lifespan of a typical Broads motor boat is 30-40 years, the biggest single commercial challenge for vessel retro-fit electrification is the fact that the diesel-powered engine is the hub for numerous interconnected on-board systems. Removing the engine and fuel tank necessitates the replacement of almost every other system on board, making the challenge of keeping costs low proportionately greater than purpose-building vessels to run on electrical energy. For example, existing systems take advantage of low engine efficiency by capturing some of the waste heat for use in the domestic hot water system. Replacing water and space heating equipment with electrical services to deliver similar performance drives up costs in proportion to the need for sufficient battery capacity.

7. The Broads boating industry remains largely traditional in its approach to development. Tried and tested ways are favoured over cutting edge technology, as systems must be easy for all customers to understand and readily fixable on the river bank when something goes wrong. Operationally, it is considered desirable to maintain consistency across a hire fleet, with all boats sharing similar components where possible, to simplify servicing and repairs. This further stifles development, as compelling reasons are needed to introduce non-standard systems when building a new vessel. The demonstration will therefore offer valuable insights into what works and what doesn't and add confidence to making the investments required to convert serviceable vessels to clean energy systems before the end-of-life replacement of existing vessels is required. By which time it is anticipated the availability of purpose built MEV holiday cruiser vessels will have expanded.

8. We anticipate a similar evolution in range anxiety to the EV market, once MEVs are proven to be a viable alternative to fossil fueled craft. However this places an emphasis on the integration of marine and shoreside systems such that they can remain complementary and capable of scale-up as the demand for services grows from an increasing number of MEV operators and owners in line with an increased technology diffusion and adoption rate.

9. This barrier is also an opportunity to increase the sustainability of parts of the local economy dependent on boating. The proposed demonstration project will inevitably hit technical challenges and some barriers for which new solutions must be found. These in turn will help to generate new skills that could form the foundations for an exciting new era affecting the inland waterways marine economy more widely. As the retrofit of other vessel types progresses, a second demonstration project would help to prove whether developments from the first demonstration can successfully be deployed on a wider range of vessels and supporting infrastructure.

10. In a retrofit scenario the physical characteristics of the vessel must be carefully considered to accommodate systems it was not originally designed to carry, without a complete strip down to the hull and a total rebuild. The latter is to be avoided in the proposed demonstration to reduce costs by minimising the amount of strip-out and refit required. Ideally, the replacement systems (electric motor, batteries, onboard battery charger(s), hot water cylinder) will fit into the space vacated by removing the old ones (engine, fuel tank, hydraulic drive, smaller hot water cylinder). However, since

the batteries will weigh 2.5 times more than the fully-laden fuel tank, the positioning within the boat is a key consideration. It is anticipated, with time and investment, this barrier will be overcome, and avoided as new holiday cruiser MEVs are launched – but demonstration of retrofit solutions is critical at the early stages of technology diffusion.

## 10. PROJECT CONCLUSIONS AND RECOMMENDATIONS

In this section we will present our final conclusions relating to this project and make recommendations for future programmes supporting clean maritime innovation.

### 10.1 Summary conclusions

Based on our feasibility study, we have concluded that it should be possible to operate a fully electric hire cruiser on the Broads, provided adequate shoreside infrastructure is in place. We recommend proving this with a demonstration project.

In conducting this feasibility study we have responded to the broad body of policy that is driving the transition to net zero in the maritime sector in the UK. We have also identified where discrete regulatory frameworks overlap with, and are pertinent to, the proposed demonstration in Phase 2 (Chapters 5.6 and 6). We have found implementing clean inland waterways vessels to be a challenge, due to their 'whole systems' nature, and there are a disparate number of marine and shoreside regulatory constraints. Within these the possible solutions require a balance to be found in the following ways:

- Scalable technical solutions to displace dominant fossil-fuelled propulsion, heating and cooking systems for holiday vessels. These will initially depend upon battery systems for energy but could, in the future, develop to include hydrogen fuel cells.
- A sufficient number of shoreside battery charging facilities that are amenable to vessel operators, and positioned where they are needed to perform a mix of rapid and fast charging, utilising both AC and DC connections. This will depend on developing understanding of typical operational energy demand profiles in order to target locations for ECPs, which in turn depend upon sufficient capacity in the electricity system to facilitate connection - otherwise there will be a requirement for RET augmentation at locations where conventional connections are not possible without grid reinforcement.
- Overall affordability of both marine and shoreside requirements should present an attractive business case to vessel operators and in turn, be a trusted and reliable product for wider adoption. Reliability is also directly related to customer perceptions and mitigates 'range anxiety'. As with road EVs, it is anticipated that with affordability derived from proven designs and service reliability, which is a primary justification for the proposed demonstration and beyond, adoption of inland MEVs will become increasingly attractive. Our feasibility study currently rates the affordability issue as a redline to adoption of inland MEVs (see Chapter 9).

The above conclusions are represented by the interconnection of challenges facing MEV adoption described in Figure 4.1.

In terms of the business case for the ETB demonstration proposal, we describe in Chapter 5.4 how implementing electric vessels on the Broads is justified not only from an emissions and environmental perspective, but because it could stimulate MEV adoption from the learning entailed. In turn, with sufficient coordination and engagement by the local electricity network operator

(UKPN) this could enable benefit stacking by hire cruiser operators, improving the business case overall. However, we recognise that due to the high front-loaded investment in converting and building new MEVs, none of this is likely without central government support until an affordable market is established for essential components – such as batteries, power conversion electronics and grid connections to chargers. The project will benefit however from the use of shoreside charging equipment which is derived from automotive EV technology.

Anticipated costs of £783,010 have been derived in [Appendix 8](#) to deliver the detailed plan of the proposed demonstration (See Gantt\_10008242.pdf) which spans September 2022 to March 2024. These include not only the final designs and retrofit of the demonstration vessel but also the implementation of the shoreside infrastructure supporting charging, operational and data management. This lays out what we called the Minimum Viable Infrastructure for the demonstration and provides a foundation for scale up with the rollout of more MEVs.

In Chapter 8, we described the need for such innovation in terms of ‘saving’ a valuable contribution of at least £18mn<sup>68</sup> from boating holidays to the local economy as part of the income from 100,000 visitors (and increasing) to the Broads each year. While the proposed demonstrator presents a negligible impact on jobs, if the results and further financial support are favourable, we estimate it will sow the seeds for as many as 58 new highly-skilled technical jobs in the Broads hire sector by 2050. This will be dependent to some extent on the pace of fossil fuel displacement from hire vessels and how the boatyard capacity is managed.

We estimate the longer term economic impacts, should electrification follow the pathways described in Chapter 7 (Table 7.15) and Chapter 8 (Table 8.4), to potentially contribute as much as an additional £0.5mn per annum (once all the hire fleet are electrified) to the local tourist industry and up to £72mn to supply chain industries cumulatively to 2050. However it is recognised that due to the supply chain for the most significant electric retrofit components originating overseas, much of this GVA will be lost to UK Plc. Battery systems, which also contribute a large upstream emissions impact, may be an exception to this loss of revenue however, should the British EV battery manufacturing facility currently under construction near Sunderland be able to provide solutions for the demand from MEVs.

In addition to contributing to the net zero maritime objective outlined in the Clean Maritime Plan, there will be environmental benefits from the removal of noise and GHG emissions, electrified vessels being quieter and less polluting than conventional ones.

Without pathfinding ways to decarbonise the Broads hire cruiser sector in particular, a cascade of negative local economic impacts is likely to occur in the next 10 to 15 years as progress towards net zero gathers pace. We must start to prepare now for the loss of automotive diesel engines, to avoid the outcomes to marine vessels described in Chapter 8. Targeted policy drivers have already started to pursue clean inland waterways transport in other places, as [Appendix 11](#) illustrates.

The good news is that our feasibility study tells us that technical solutions can be found and so the next step is to bring these together in the proposed demonstration. Our study has found the most

---

<sup>68</sup> This figure is just the income directly related to boating in 2019.

viable partner is Torqeedo – to supply the powertrain, and assist in its integration to the Broads hire cruiser we have selected for demonstration. We look forward to working with them to adapt their technology to the unusual requirement of a large onboard energy store combined with a small propulsion power requirement. Due to the limited availability of resources, it will be necessary however, to confirm our partnership at the earliest possible opportunity to secure the required expertise. We have also identified a shoreside charging supplier (EO) who offer suitable shoreside chargers, which RenEnergy have the competence to install.

As Chapter 5.5 shows, the current costs likely to be incurred in demonstrating solutions would be prohibitive to an unfunded private operator and so pose a barrier (as described in Chapter 9) to adoption and scale-up without central government support to stimulate rollout. We believe this is another compelling reason to run the proposed demonstration, so that with greater understanding we can have more confidence in solution design – and therefore cost solutions for wider rollout more accurately.

There are risks of delays to project execution through the unusually long time it takes for essential information to be gathered from the key agencies we must work with in order to deliver a demonstration and rollout after that. Not only is the distribution network serving the Broads weak and constrained, but our experience of working with UK Power Networks has also been curtailed through delays in providing information on substation headroom capacity - necessary for planning shoreside charging infrastructure. Adding to this, was disappointment with UKPN on the identification of MEV2grid connection opportunities, which should be encouraged due to the market for flexibility services to the weak network serving the Broads. While we have dropped this element from the objectives of the proposed demonstration (see Chapter 5.2) we hope that this impedance can be overcome in future as it will open up opportunities to improve the business case in favour of investment in battery driven MEVs, as described in Chapter 5.4.

## 10.2 Emissions conclusions

In Chapter 7, we found that the proposed demonstration is justified in terms of focussing on the conversion of the holiday hire sector to clean energy. Emissions savings could be up to 20.8 ktCO<sub>2</sub>e by 2050 by converting the hire cruiser sector, representing 9% of Broads registered motor vessels. This is equivalent to about 18% of emissions from the entire Broads fleet.

In a hire sector vessel-for-vessel comparison, the proposed electrification was shown to save approximately 13 kgCO<sub>2</sub>e/day in cold conditions and 16 kgCO<sub>2</sub>e/day in warm conditions, representing a 42% to 54% improvement compared to an equivalent ICE powered (control) vessel (see Table 7.12).

Lifecycle savings included the emissions impacts from both the shoreside charging equipment and onboard battery bank upstream emissions, as well as electricity generation and T&D losses. The biggest single known upstream emissions footprint currently comes from the battery bank system at approximately 4.7 tCO<sub>2</sub>e for the 84.4kWh battery in the proposed demonstration. This value could reduce significantly if batteries were built in the UK and utilised renewable electricity in the construction.

While the upstream emissions associated with the MEV shoreside charger were relatively small when amortised over a 10 year service life, the use-phase electricity to charge the batteries makes a significant impact on lifecycle emissions (although on a kWh for kWh basis it is preferential to fossil fuels<sup>69</sup>) and would benefit by about 0.2 kgCO<sub>2</sub>e/kWh from direct use of locally generated renewable energy.

No account, for life cycle comparisons, was taken of the incumbent ICE 'control' vessel upstream emissions, apart from the Well-to-Tank emissions in providing the fossil fuel consumed. The emissions saving from conducting the proposed demonstration in Phase 2 and over the remaining service life (up to 10 years), before key components (batteries and chargers for example) require replacing, are reproduced below from Table 7.13.

<b>Duration years</b>	<b>Cold conditions</b>	<b>Warm conditions</b>
2022-23 (Demonstration period, 1 year)	1.6	2.1
2023-28 (5 years)	8.2	10.5
2023-33 (10 years)	16.4	21.0

A benefit of around 5,232 tCO<sub>2</sub>e/year (by 2025), accumulating to 115ktCO<sub>2</sub>e by the year 2050, could be realised if the entire Broads fleet emissions were saved (using 2021 baseline data) but this was considered unlikely for a number of reasons – principally connected to the cost and the capacity to convert over 8,000 vessels in the 27 years from 2023. Even clean energy systems present an emissions footprint due to life cycle considerations under current conditions, which mitigate against some of the benefit from displacing all fossil fuels. However, looking beyond the demonstration, upstream emissions from new clean technologies will change and electrification may not remain the only means of saving emissions, as conversion to other carbon neutral fuels, such as hydrogen, becomes possible.

### 10.3 Recommendations

Our experience of carrying out this feasibility study led us to making the following recommendations for future programmes to support clean maritime innovation:

- The proposed demonstration will provide essential data to model the needs of inland waterways vessel electrification going forward. However, it will be limited by the presence of only one retrofitted vessel and AC type of shoreside chargers. This study also identified a range of shoreside technology combinations that would be necessary to evaluate under operational conditions when there are a greater number of electrified vessels under trial. We therefore recommend that the learning from the proposed demonstration be applied to a follow-on demonstration with a larger number of vessels and a wider range of shoreside infrastructure, such as 'Phase 2 Plus' described in Table 5.2.

<sup>69</sup> At current UK Government values (2021), electricity saves about 0.11kgCO<sub>2</sub>e/kWh from use of gas oil.

- Clean maritime challenges are often part of an intersection of governance frameworks and related systems - not all maritime in nature. For example, land-based energy systems are essential to supporting maritime decarbonisation. We recommend that multi-agency coordination and funding should be considered to demonstrate solutions involving interconnected system challenges. We concur with recently published research published by UKRI, reflecting the benefits of place-based solutions in achieving Net Zero.<sup>70</sup>
- The acceleration of bidirectional charging is considered a desirable element to maximise the utility of electrified vehicles including marine vessels. We recommend more engagement by the DNOs in accelerating this aspect of electricity network innovation.
- Data is lacking in the inland waterways sector to understand many aspects of the challenges in achieving clean maritime objectives. We recommend Licensing Authorities seek to obtain more detailed information about vessel systems and usage, although it is recognised that owners may be reluctant to engage beyond the minimum legal requirements. Support for projects where data acquisition is built-in (such as the proposed demonstration project) will be critical. This will help in modelling the changes and innovations necessary to achieve a clean maritime future.
- If funding calls were prepared together with a clear reporting framework for project proposals to be structured accordingly, this would save valuable time and effort for competition participants. We commend the use of a standardised reporting framework but its publication as a requirement for funding is recommended at the earliest opportunity to increase the efficiency of project delivery.
- We recommend Government support aligned with the need for policy driven changes so there is sufficient time for projects to deliver solutions commensurate with net zero and clean maritime ambitions, and reduce risk to transition economies. In the case of the Broads, the CMDC, because it is forward looking, is well timed to support the local economy in the transition to zero emission vessels.
- Business cases for approving essential government investment to prime a low carbon transition may not always look very positive. However, government funding is essential to pathfind and seed suitable technical, behavioural and economic changes required for net zero. We recommend the Government continue to support such projects that are instrumental in pathfinding the way to clean maritime solutions.
- We recommend aligning and developing the production of UK-made EV batteries with the inevitable demand from the MEV sector while also satisfying road based EV demand.
- We recommend sponsors ensure timely commencement of approved projects, as delays in planned initiation can result in snowballing impacts upon consecutive tasks required to deliver the project. This is especially important in current times of supply chain disruption.

---

70

<https://www.ukri.org/wp-content/uploads/2022/03/IUK-090322-AcceleratingNetZeroDelivery-UnlockingBenefitsClimateActionUKCityRegions.pdf>

## APPENDICES

## Appendix 1 - Broads Authority survey and census

The Broads Authority conducted a survey over a 3-week period during June/July 2021. To comply with GDPR the survey could not be distributed through the Broads Authority registration and toll charge database. It was instead distributed by social media through the Broads Authority Facebook page, shared on the Broads Forum, and through the assistance of boatyards passing it on to their customers. The purpose of the survey was to collect data from owners and users of powerboats to inform the Broads Authority positions and policies on green boating.

The survey collected data on the type of boat, length of voyage, type of propulsion and fuel, interest in transition to low carbon/ alternative fuels, perceived barriers to the use of low carbon/alternative fuels and the use of subsidies to encourage the uptake of low carbon/alternative fuels.

Whilst the data provides a useful insight into the opinions of boat users on the Broads, as with many public surveys there are limitations in the data. The survey was a 'self-selecting' sample of respondents and although the communities it reached is fairly broad, it excludes those not active online or taking part in the various Broads social media or online forum groups. The demographics of the people surveyed are also unknown, as is their location and whether they are local to the Broads and therefore have a better understanding of its navigational routes or a vested interest in the Broads.

Key findings from the surveys are as follows;

- Private motorboats with an average length of 8.7m (without a sleeping berth) and 10.69m (with a sleeping berth) are the most popular type of private boat using the Broads.
- Diesel propulsion is the most common type of fuel (72%) followed by petrol (23%). Only around 5% of responses reported current use of a renewable fuel source (electric, biofuel).
- 64% of private boats operate with a single inboard engine.
- 87% of respondents use their boat for overnight stays
- 44% of private boats use diesel for onboard heating and air conditioning. Other fuels cited include gas oil (red diesel), bottled gas, electric, paraffin and petrol.
- 81% of respondents replied that they would like to use green fuels but the cost is too high (converting current boating/purchasing electric boats). Other barriers cited included inconvenience around access to alternative fuels and electric charging infrastructure.
- 81% either agree or strongly agree with the statement 'I would like to use greener fuels, but convenience of greener fuels is too low (e.g., lack of electric charging infrastructure, lack of biofuel availability)'

Of the positive written responses received, many respondents with older vessels raised concerns over transitioning to electric propulsion favouring biofuels as an alternative approach. Cost, the contribution recreational craft can make towards climate change targets, impracticalities and disadvantages of alternative fuels and lack of mooring and charge points were all cited as reasons against transitioning to electric propulsion. The following written response provides a user's insight into the potential challenges for shoreside infrastructure and the transition to electric propulsion.

“It is completely impossible for there to be sufficient charging points at all the miles of formal and informal moorings along the broads and rivers. During busy periods every available mooring spot is occupied overnight. Given the lack of infrastructure and the limited range of an electrically propelled vessel, electric propulsion, other than for day boats, is impossible.” (Anonymous responder to Broads Authority Survey)

In addition to the online survey, the Broads Authority also carried out a face-to-face survey during the same period at Ranworth, a popular tourist destination. A total of 10 groups of boat users were asked to share their opinions on electric boating. All groups had hired diesel-powered motor cruisers with an average length of hire of 1 week, within a range of 5 days to 3 weeks. Of those surveyed most had visited the Broads at least once before, although first-time visitors to the Broads were also included.

Participants were asked to share their thoughts on electric boating and whether they would be interested in hiring an electric boat, if available. Six out of the ten groups surveyed raised access to charging and moorings being a potential barrier, whilst five out of the ten groups raised cost being a prohibitive factor. Despite raising concerns over insufficient infrastructure and cost, four of the ten groups would like to hire an electric alternative if it were available citing reasons of conservation of the environment, nature and quiet.

Figure A1.1: Boat census locations

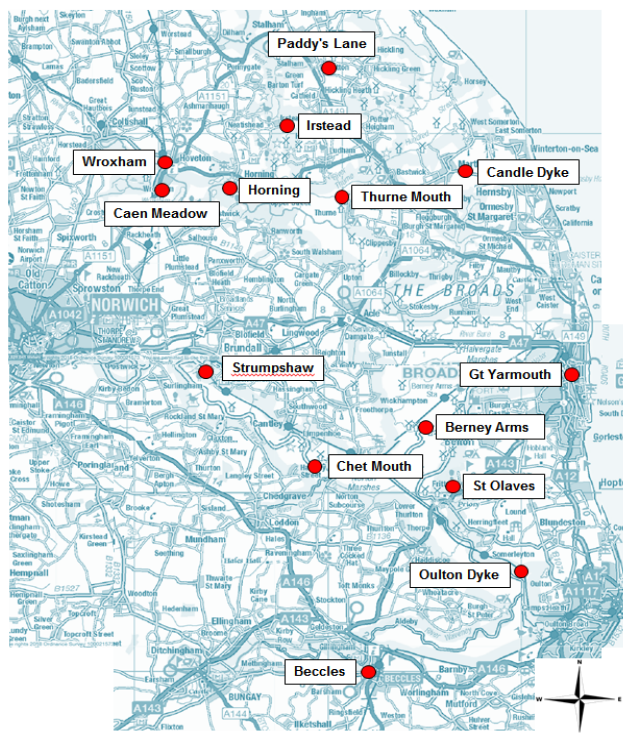

## Boat Census - movements by vessel type

Every four years the Broads Authority carries out a “Boat Census” on the Broads. This is an assessment of usage patterns on the rivers and used to plan infrastructure needs such as mooring points. The census is carried out during August over 3 days by BA Officers and Volunteers, and consists of a count of boats passing at the points shown in Figure A1.1.

The last census was carried out in 2018, and the next one is due in 2022. 11,715 boat transits were recorded during the census, although it should be noted that the count is of transits, rather than vessels, so there is some degree of double-counting where vessels pass more than one location.

As Figure A1.2 shows, for motor cruisers, there were 4,401 hire vessel movements recorded, and 2,061 for private vessels. This implies that in August, hire cruisers as a group are doing approximately twice the distance of private vessels, despite being only 12% of cruisers on the river. It is not possible to determine from the data if the August snapshot is typical over the year - indeed some private vessel owners may avoid peak season and prefer to cruise during the “shoulder” seasons when the waterways are less crowded.

There were also 2,757 hire day boats/outboard dinghies and 637 private day boats/outboard dinghies recorded. Day hire boats may be more likely to be double counted as they will need to return to base after the hire period expires.

**Figure A1.2: Boat census data**

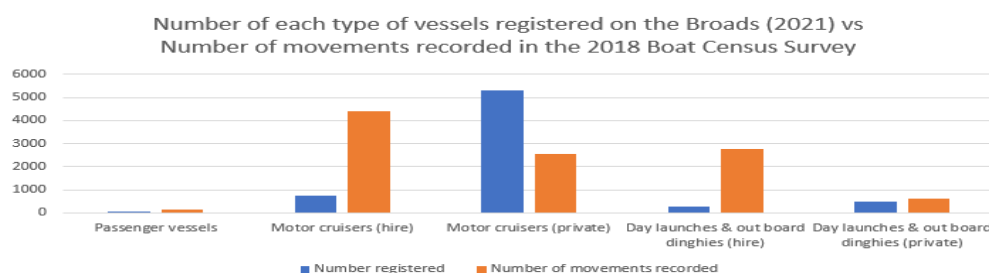

## Boat Census - moorings

Due to the local conditions and high prevalence of reed edging to the waterways in the Broads, users generally have to moor at designated mooring places. The Broads Authority operates a number of 24-hour moorings around the network, complemented by the Environment Agency and other third-party mooring places, including pubs, boatyards and marinas. Some of these locations already provide electrical hook-ups, but these are typically low power and would likely need upgrading to provide vessel charging (see Figure A1.3, below).

The majority of moorings are Broads Authority owned (85), with the remaining operated by third parties (60). Of the 85 Broads Authority moorings, 18 have at least one electrical hook-up, and some, such as Ranworth Staithe, have 4.

Alternatively, all boats come equipped with a mud weight, a form of anchor that can be used on the soft sediment of the Broads. This can be used to rest at anchor in the Broads. Other “wild mooring” can sometimes take place at other points in the network, but is less easy than on a canal.

The high density of vessels on the Broads means that users often refer to a shortage of convenient mooring points. This congestion will need to be carefully considered as we evaluate where to establish charging infrastructure.

**Figure A1.3: Map of current official moorings**

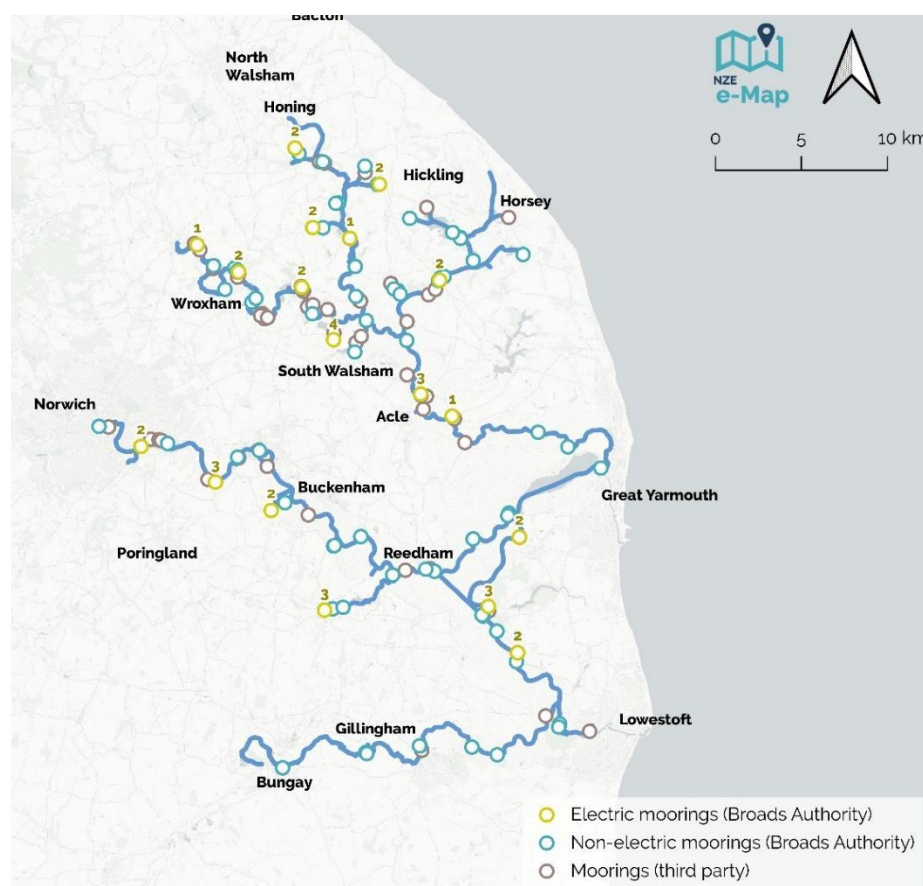

In preparation for this study, the Broads Authority reviewed a stretch of the Bure known as a particular hotspot for this issue, running from Wroxham & Hoveton to South Walsham (see Figure A1.4, below). This sits at the centre of three major hire boat areas - Stalham on the Ant, Wroxham on the Bure, and Potter Heigham and Ludham on the Thurne<sup>71</sup>.

The survey was carried out using two methods; firstly, a review of aerial photography held by the Broads Authority, taken in 2017 and 2020 and secondly, an in-person count of boats performed by Broads Authority rangers and volunteers in August 2021, on a Friday and Saturday evening.

<sup>71</sup> The green line is the Broads Executive Area Boundary, the blue lines show the centre of the navigations. The three black arrows show the start and end points of the survey, and the red arrow shows Ranworth Staithe. Blue stars indicate major boat hire yards in the area. Red stars show locations with mooring pressure. Green stars show locations without mooring pressure. All locations are approximate

Figure A1.4: Map showing the area of the 2021 BA mooring review.



In Figure A1.4 above, green stars show moorings surveyed with spaces available, Red Stars show moorings surveyed with no or limited spaces, green those with spaces. Black arrows mark the end points of the mooring survey.

Moorings with limited or no spaces included;

- Ludham Bridge - adjacent to the Ludham Bridge Stores and the Dog Inn at Ludham
- St Benet's Abbey - adjacent to the Abbey, although no other facilities in easy reach
- Ranworth Staithe - adjacent to the Maltsters pub, and a short walk to the Broadland Conservation Centre. Ranworth Staithe (on Malthouse Broad) is a known hot spot for tourism
- Horning Staithe, Swan Inn and Swan Green - all in Horning with access to the village shops, pubs and restaurants. There remain spaces at the Ferry Inn in both surveys. Percy's Island, on the opposite side of the river to the village, also has spaces.

Wild mooring is defined for these purposes as mooring outside of a designated mooring point, either third-party or Broads Authority. The 2021 survey counted 12 boats wild moored, largely by anchoring with a mud weight, but with some mooring on the reeds at the edge of the river.

In total there are approximately 300 mooring spaces on this section of river. This is not an exact number, as it depends on the length of the boat mooring, and how “efficiently” they are moored. There are also some moorings that allow for “double” moorings, where a boat moors up alongside one already attached to the bank.

The aerial photograph count showed 177 boats at moorings, and the in-person count showed 186 boats at moorings, showing about 60% of mooring capacity has been used with a high degree of confidence in the measurements (5% error). It is important to note, however, that this is just the headline figure, and does not consider the desirability of moorings. In the August survey, of the 28 individual mooring sites, 8 (29%) had zero spaces. These are generally the moorings adjacent to pubs or visitor attractions.

Overall, collecting the data for the project posed the following challenges that should be considered in assessing the results:

- The Boat Census only captures when a boat passes a specific point. It does not record how far a specific boat has travelled
- The difference between a hire boat and a private boat is determined by the person counting boat passages identifying the Hire Boat Company logos on the vessel - it is not guaranteed that this is always reliable
- Gathering mooring data is challenging as it requires significant person hours to cover the waterways, and relies either on a ranger being on patrol at a convenient time, or specific journeys being made
- The most recent aerial photographs of the Broads were taken in April 2020 when the full national lockdown was in effect. This prohibited private use of vessels, and apart from a handful of continuous cruisers, all private and hire boats would have been at their base marinas or moorings. This means we have used older 2017 photos.
- Gathering face-to-face data from tourists has been challenging during Covid - small scale surveys on attitudes have been carried out, but are of limited value due to sample sizes.

## Appendix 2 - Norfolk Broads Direct survey

Hire boat operator Norfolk Broads Direct also carried out their own online customer survey on 29th September 2021 entitled 'The Future of Broads Boating'. The purpose of the survey was to help shape the future of the Broads holiday offered with a strong focus on greening future operations. The survey was sent out to 7,336 existing customers and is reproduced below.

Of the 624 responses to the surveys, 79% plan to holiday on the Broads in the future with 67% preferring to holiday on a boat for 7 days. Under half of respondents would choose an electric powered hire cruiser if available with a higher proportion (49%) of respondents answering "maybe", citing reasons of range, availability of charging points and cost.

In answer to the question "Would you be prepared to pay more for an electric powered cruiser?" over 53% said 'no', 37% answered 'maybe' and only 8% answered 'yes'. The availability of electric charging points was cited as the main factor that would deter respondents from choosing an electric-powered cruiser over a diesel-powered cruiser. Despite this hesitancy, when asked whether they would continue to holiday on the Broads if only electric powered cruisers were available 61% responded positively with only 8% answering no.

In analysing the responses from both sets of data from owners and users of hire cruisers two common themes emerged:

1. accessibility to charging points (both in number and location); and
2. concerns about prohibitive costs of retrofitting electric propulsion for private owners and perceived additional cost of hiring an electric powered cruiser for holiday makers.

## The Future of Broads Boating Survey

**624**  
Responses

**09:02**  
Average time to complete

**Active**  
Status

1. Do you plan on taking a Broads boating holiday in the future?

<span style="color: blue;">●</span> Yes	494
<span style="color: orange;">●</span> No	19
<span style="color: green;">●</span> Maybe	111

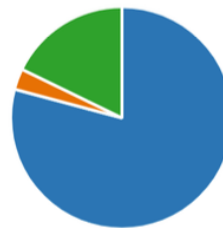

2. What is your preferred Broads Boating holiday duration?

<span style="color: blue;">●</span> 3 nights	17
<span style="color: orange;">●</span> 4 nights	93
<span style="color: green;">●</span> 7 nights	422
<span style="color: red;">●</span> 14 nights	51
<span style="color: purple;">●</span> Other	41



3. When choosing a boating holiday which of the following is most important to you?

■ Not considered  
 ■ Not Very Important  
 ■ Slightly Important  
 ■ Very Important

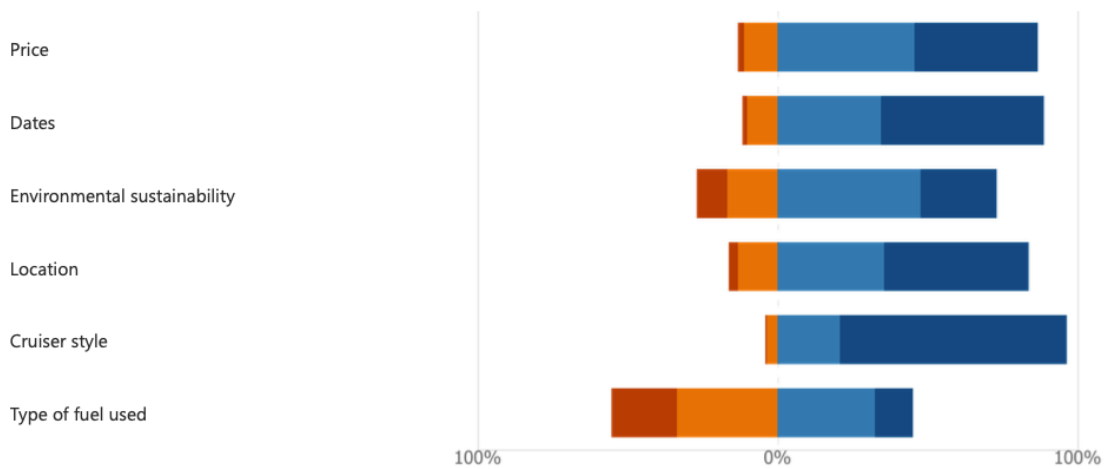

4. Would you chose an electric powered hire cruiser if one was available?

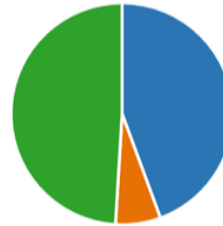

5. Why did you give the answer you gave to question 4?



Latest Responses  
"Depends on layout."

"There are so few boats available, I would consider only if there was..."  
"Reliability unproven but I realise there is ongoing pressure to reduc..."

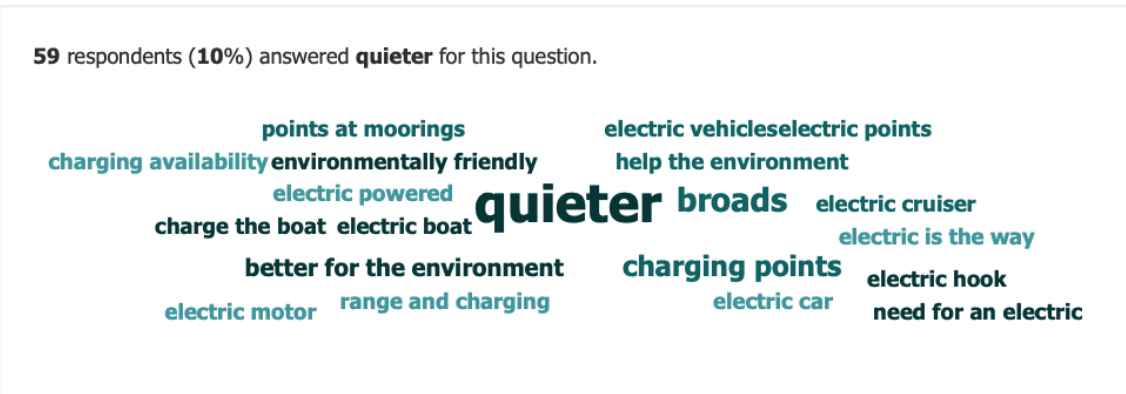

6. Would you pay more for an electric powered cruiser?



7. Would any of the following make you more likely to choose and electric powered holiday cruiser over a diesel powered cruiser?

■ Maybe ■ No ■ Yes

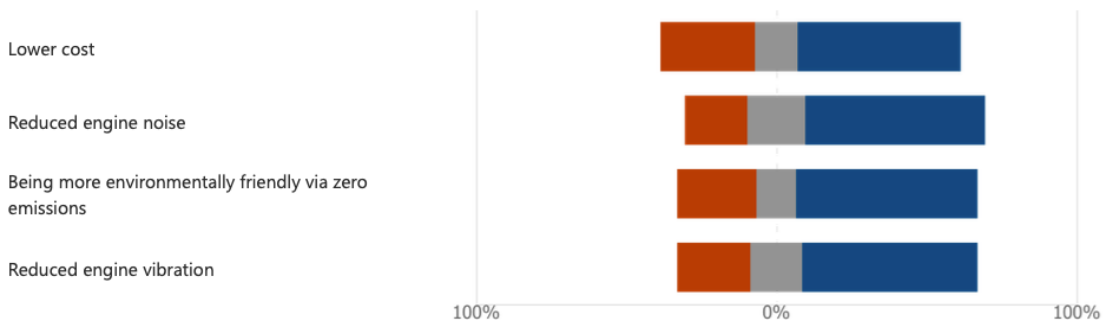

8. Would any of the following make you less likely to choose an electric powered holiday cruiser over a diesel powered cruiser?

■ Maybe ■ No ■ Yes

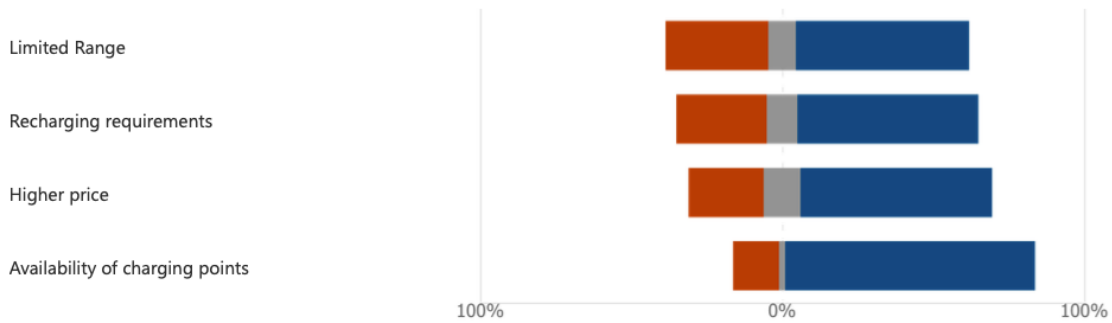

9. Would you have any other concerns about hiring an electric cruiser if one was available?

404 Insights Responses

Latest Responses  
 "No"  
 "probably reluctant at present"

40 respondents (10%) answered **charging points** for this question.

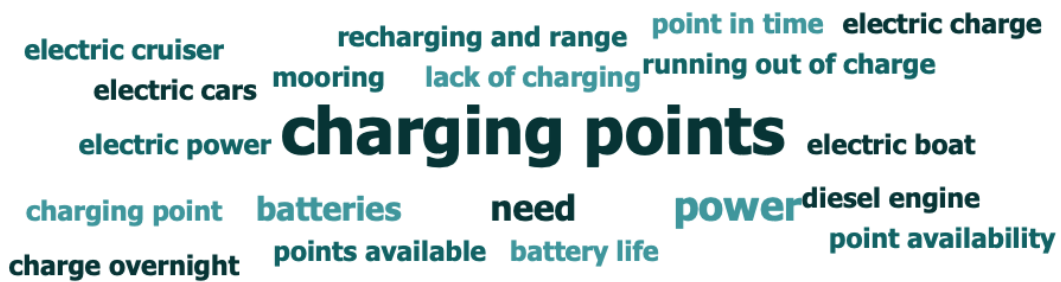

10. Would you continue to holiday on the Broads if only electric cruisers were available?

Insights

Yes	382
No	53
Maybe	189

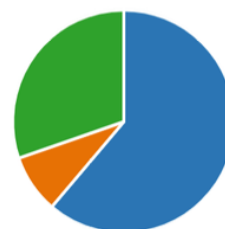

11. What would you like to see in the future of hire boats?

451 Insights Responses

Latest Responses  
 ""

Responses

"More luxury, en suites etc Better and more availability of moorings."  
 "Less boats on the river as there are now too many which has reduc..."

146 respondents (32%) answered **boats** for this question.

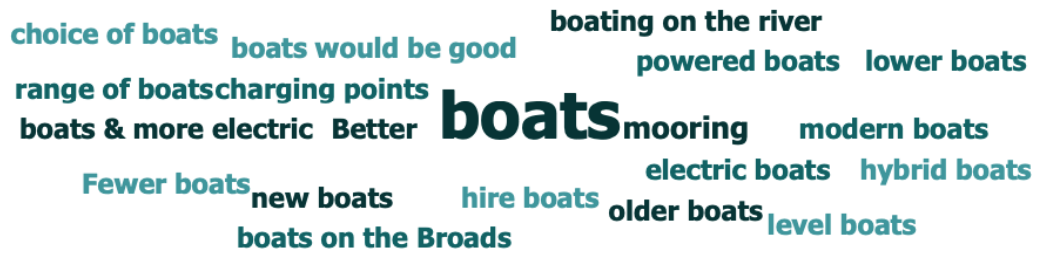

### Appendix 3 - Estimation of demonstration vessel sub-system electrical energy demands

In almost all current hire fleet vessels the main propulsion unit is a marinised version of a diesel automotive water-cooled piston engine, with a rated power of 17kW in smaller vessels, up to 62kW in larger vessels. The engine provides drive either directly to a propeller, or more commonly through a hydraulic drive system. Hydraulics also provide power to the bow thruster in the study vessel class. (See Figure 7.4, below.)

Figure A3.1: Subsystems from a typical Broads holiday cruiser

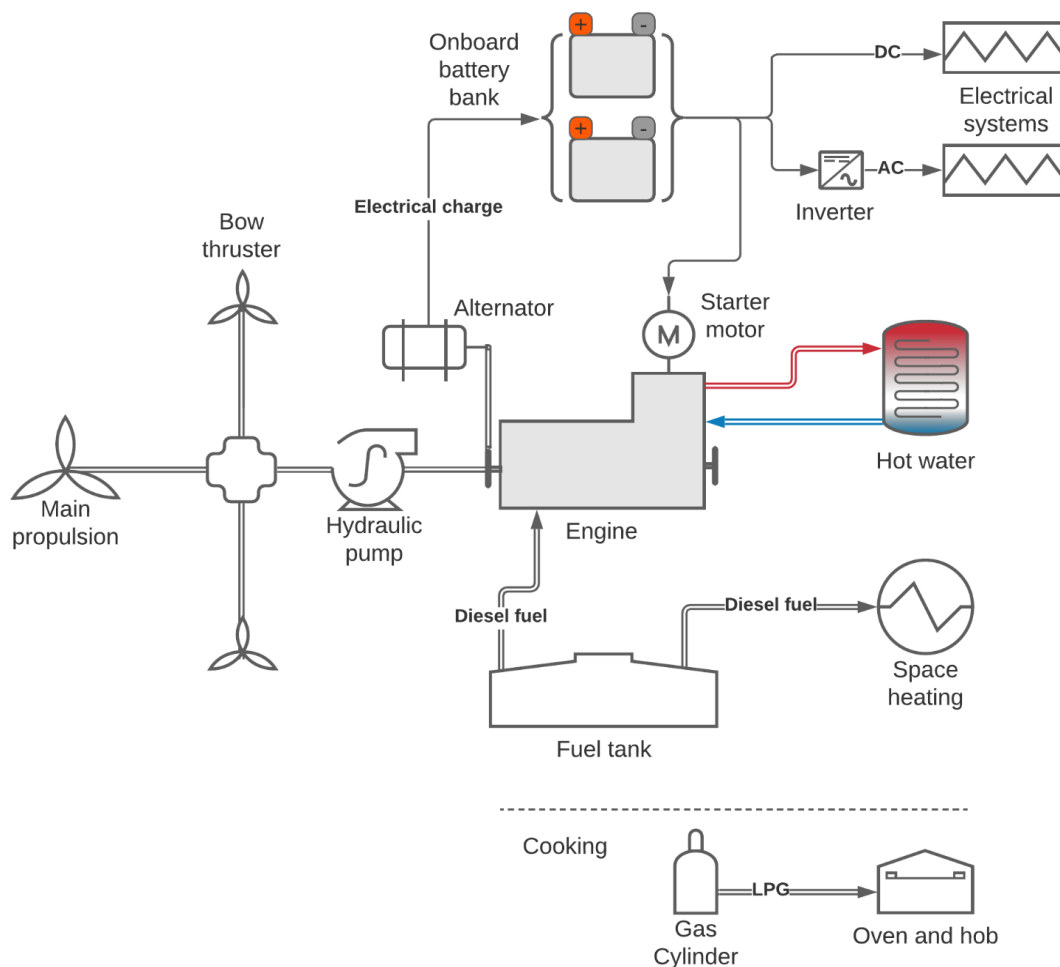

A belt-driven alternator charges a starting battery and a set of leisure batteries in the normal way. These are connected to the AC (via an inverter) and DC loads, including the engine starter motor.

Domestic hot water is provided via a pumped system. A hot water tank (calorifier) is used to transfer heat from the engine's closed coolant circuit to the domestic water ready for use. The engine's coolant system typically operates at ~80°C and the calorifier will equilibrate with the circuit. For this reason the delivered hot water is mixed with cold water to ensure outlets are supplied with water at a safe temperature, typically 45°C.

Physical data relating to the vessel identified for study above, are presented in Table A3.1, below.

System	Dimension	Notes
Engine	Type BETA (or Perkins) 55hp (41kW)	Weighs 260kg
Fuel tank capacity	230 litres	Weighs approx 240kg when full
Heater system weight	20kg	Runs off main fuel tank
HW calorifier tank capacity	Surecal, 55 litres	55l tank weighs 70kg when full
Potable cold water tank capacity	450 litres	
Existing battery bank (12V)	7 x 115Ah AGM batteries; or 7 x 115Ah wet cell batteries	Weighs 231kg Weighs 168kg run 230V inverter
LPG bottles and gas cooking appliances	2 x 13.2 kg LPG cylinders	31x31x56cm per cylinder

### Propulsion energy demand

If we consider the histogram (Figure A3.2, below) of daily fuel consumption across all NBD holiday hire cruiser types and cruise durations from 2018-2020, we can see the most common daily fuel consumption is between 10.9 to 11.7 litres/day.

Diesel fuel usage per day (litres) for all cruise durations in years 2018-20

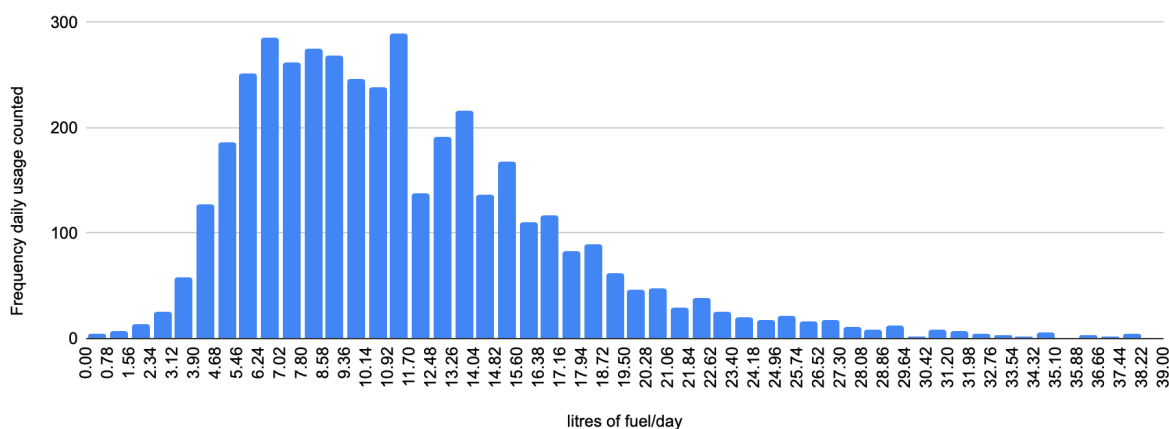

Figure A3.2: Histogram of average daily fuel consumption (Note. outliers above 39l/day have been excluded).

The above baseline daily fuel consumption can be qualified by the following considerations:

- Average daily fuel consumption varies across hire seasons and will be affected by ambient temperatures in relation to additional energy demand for space heating.
- On average, the longer the holiday, the more fuel in total for the cruise will be used. However, short breaks use slightly more fuel per day than those cruising for a full week.

- We cannot determine the most fuel ever used in a single day during the target cruise duration from this data but our approach addresses the most frequent sample.
- Typical propulsion efficiency for a hire cruiser marine diesel engine is about 33%.

From the above analysis, we will estimate daily propulsion energy according to Formula A3.1

*Formula A3.1:*

*Propulsion energy<sub>electrical</sub> = Average of most common daily fuel consumption \* Engine efficiency \* conversion factor (diesel to kWh)*

$$\text{Propulsion energy}_{\text{electrical}} = 11.3 * 0.33 * 10 = 37.3 \text{ kWh/day}$$

### Ancillary energy demands

Ancillary energy demands that will have to be taken into consideration include DHW, cabin heating (seasonal), lighting, refrigerator, television, water pump, bow thruster, windlass and minor plugin devices such as mobile phones and laptops. Cooking energy is normally provided by an autonomous bottled LPG system, but we will make equivalent electrical demand estimates.

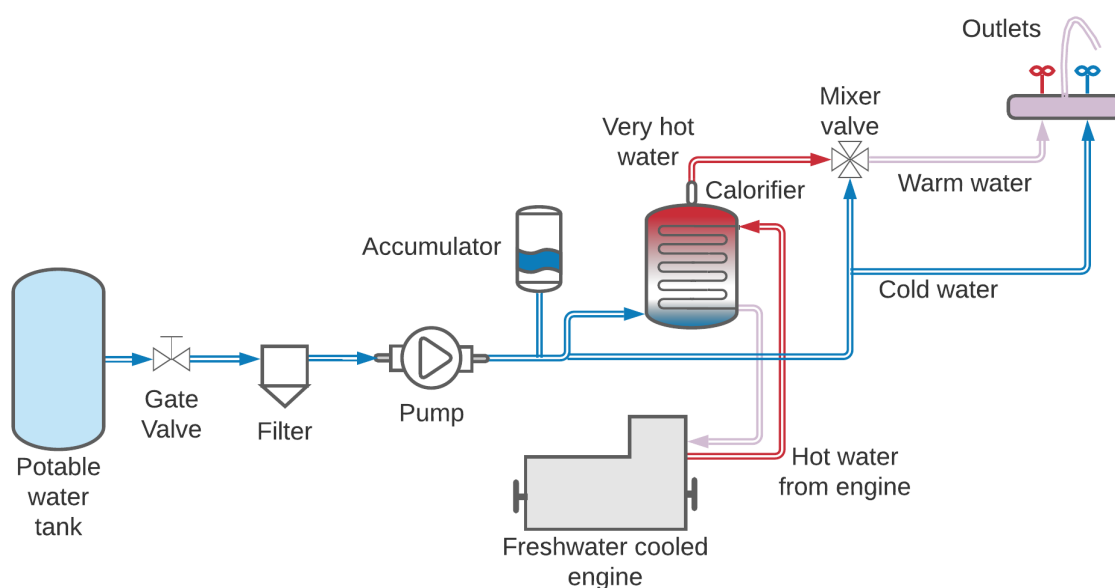

**Figure A3.2: Schematic overview of existing hire cruiser water heating system**

#### Hot water

There are no data available to identify how much hot water is used by hire boat customers whilst holidaying on the Broads. An estimate, based on figures for UK households, is that 10 litres per person per day is used for showering and a further 10 litres per person per day for other washing and

cooking. This does not include cold water used for any other purpose. Based on 6 persons on board, the amount of hot water used per day is approximately 120 litres. This figure is likely to be less in practice as conditions are not the same as domestic usage when cruising, so we will use a figure of 100 litres as the basis for our estimates. To save energy losses from storing and mixing hot water, we opted for instant hot water devices in the demonstration vessel as these are likely to offer the highest energy efficiencies.

The planned instant hot water outlets in the retrofit vessel are rated at 2.8kW (230V AC) and are specified to heat water to 60°C, depending on the inlet water temperature and desired flow rate. With an inlet water temperature of 11°C and a flow rate of 1.5 litres/minute, the outlet water temperature is circa 35°C.

To heat 100 litres of water per day with a delta of 25°C (such as from 10°C to 35°C) for washing and showering requires the following amount of energy:  $100 \times 4200 \times 25 = 10.5 \text{ MJ} = 2.9 \text{ kWh/day}$ .

With a temperature target of 50°C in the retrofit, we would expect the instant hot water appliances to run periodic heating cycles to avoid the risk of Legionella contamination.

#### *Space heating*

In specifying the case study boat, there is no information available to identify how much diesel fuel is used by hire boat customers heating the cabin space during their holidays. However, we do know that compared to the summer months, about 10 litres more diesel fuel (100kWh) is consumed over a 7 night cruise in the winter months, some of which can be attributed to extra space heating demand (see Chapter 7). The diesel heaters are rated at between 0.14 and 0.25 litres per hour, which equates to approximately 1.4 to 2.5 kW. If used for 7 to 8 hours in every 24, then they would emit between 10 and 20 kWh of heat energy. If we take diesel fuel use as the basis and apply the entire differential between warm and cold months (100kWh) to space heating, the upper value would come to 16.7kWh/day over a 6 day cruise period.

If used more frugally, and with the addition of insulation to the vessel hull and superstructure at time of manufacture, and double-glazing of windows, then that consumption would obviously diminish to a figure approaching zero in the warmer months of the season.

As a comparison, an alternative way to estimate space heating demand is to take the energy required to raise a volume of air by a given number of degrees Celcius. To raise the temperature of air requires  $0.0067\text{kWh/m}^3$ . If we assume in the course of a day,  $400\text{m}^3$  of air is heated (this is more than the volume inside the vessel but it will be cooled by mixing with ambient air from opening of windows and doors admitting cooler air inside) by 20C, this would require 2.68kWh/day of energy.

This wide range of estimates are possibly indicative of winter and summer cases. We then researched the use of infrared heating systems which offer a more efficient delivery of comfort to vessel occupants. Consultation with a provider of these systems resulted in specification of three heaters (one for each cabin space in the demonstration vessel). The two smaller heaters are for the berths and the larger heater for the social area. We believe the results presented in Table A3.2 below offer a reasonable estimate of space heating demand under relatively cold conditions.

Type	Quantity	Nominal power kW	Operating time hours	Energy demand kWh/day
60/120	1	1.4	7	9.8
60/60	2	0.7	4	5.6
			Total	15.4

### *Cooking*

Cooking is another seasonally variable practice. Use of onboard cooking facilities in a survey of Broads boat users was analysed in a study by Colyer, 2008 and concluded “cooking [as reported by survey respondents] at about 40 minutes per day probably reflects a predisposition to eat out when on holiday”.<sup>72</sup> Preparing a roast dinner whilst on a Broads holiday would commonly be carried out when moored, using LPG cooking facilities, but could make use of a shoreside power supply to run the galley and other equipment in an all-electric vessel.

A second source of data came from The Food Refrigeration and Process Engineering Research Centre (FRPERC), which is a research centre at the Grimsby Institute of Further and Higher Education.<sup>73</sup> This source estimated energy to cook unfrozen roast dinners (chicken, roast vegetables, frozen vegetables and gravy) in three different ways presented in Table A3.3, below. In the example given, a ‘real’ roast dinner indicates the roast vegetables are included with the chicken at the same time in the cooker.

Cooking method	Chicken	Roast vegetables	Frozen vegetables	Gravy	Total kWh
Oven/hob	1.32	0.1	0.4	0.19	2.02
Microwave	1.02	0.8	0.14	0.19	2.15
Oven/microwave	1.32	0.1	0.14	0.19	1.75

The third source of data comes from NBD receipts for Propane LPG, which is used in hire cruisers for various forms of cooking. In 2018, 2,160 kg of LPG were consumed which, if divided by the number of booking nights, results in 2.76kWh/day energy demand. As this is in line with the estimates given above for more efficient electrical cooking methods, we will adopt a value of 2.5kWh/day for cooking energy.

<sup>72</sup> Helen Colyer, 2008, A Carbon Audit of the Broads Hire Boat Industry. University of East Anglia.

<sup>73</sup>

[http://www.frperc.com/FRPERC.com/Articles/Entries/2009/4/17\\_What\\_is\\_the\\_most\\_energy\\_efficient\\_method\\_of\\_cooking\\_a\\_British\\_roast\\_dinner.html](http://www.frperc.com/FRPERC.com/Articles/Entries/2009/4/17_What_is_the_most_energy_efficient_method_of_cooking_a_British_roast_dinner.html)

*The estimated daily cold weather electrical energy demand for the demonstration vessel*

Based on the above analysis, we derive an estimated daily energy demand for an electrified vessel from the following components:

Daily energy demand (kWh) = Propulsion energy + Hot water energy + Space heating energy +  
Cooking energy

Daily energy demand (kWh) = 37.3 + 2.9 + 15.4 + 2.5 = 58.1

We will round this upwards to accommodate small electrical devices to **60 kWh/day**.

## Appendix 4 - Demonstration vessel technical design details

In our analysis of technical solutions for the demonstration vessel, we pursued two approaches with different suppliers (Boat 1 and Boat 2). We selected the most mature technical solution to the powertrain from these to propose for the demonstration. This solution (Boat 1) utilises Torqeedo 'Deep Blue' technologies which provide a 50kW propulsion motor that is adjustable by the manufacturer down to 12kW. We will aim for a 15kW nominal power, according to our calculations above, and will test and measure this in the demonstration. This approach also resolves the wide DC voltage stepdown from the battery to the motor as we will be running at the original motor voltage of 96V DC but using only around 25% of its full capacity.

We include details below this of the lesser developed 'Boat 2' approach which we also researched, for reference.

### Demonstration vessel design highlights (Boat 1)

- 400V nominal drive train system including custom power motor, 10 - 20kW.
- 2 x batteries 42.2kWh each liquid cooled.
- System can be charged on a 22kW charger in approximately 3.5 hrs.
- System can be charged on a 7 kW charger in approximately 11 hrs.
- Future charging rates of 80kW AC could be achieved along with DC (CCS) charging.
- System charging rate can be controlled and customisable via onboard controller.
- Battery Maintenance and conditioning
  - Recharge batteries after every trip.
  - If batteries are discharged to below 20% recharging must occur within 48 hours.
  - In extended storage of battery, check battery levels before storing and once a month onwards.
  - Battery can be stored for one year between -40C to 30C. The irreversible capacity loss in this case does not exceed 5%.
- Compatible with auxiliary AC and DC distribution within the boat.
- Bi-directional charging is not compatible with this system as it stands, however could be reviewed if the business case was there to justify expense.
- Electrical connections tests and power up done by a qualified technician.

### Principal electrical system layout

The principal electrical systems are presented in Figure A4.1, below. Main system loads providing propulsion and bow thrust are at 400V DC. Sensor locations have been added to indicate where the points of data collection are anticipated. Figure A4.2 describes the AC distribution board wiring and loads which are taken from DCB1 ('Extra DC Load') at 24V in Figure A4.1.

Figure A4.1: Schematic of principal electrical systems

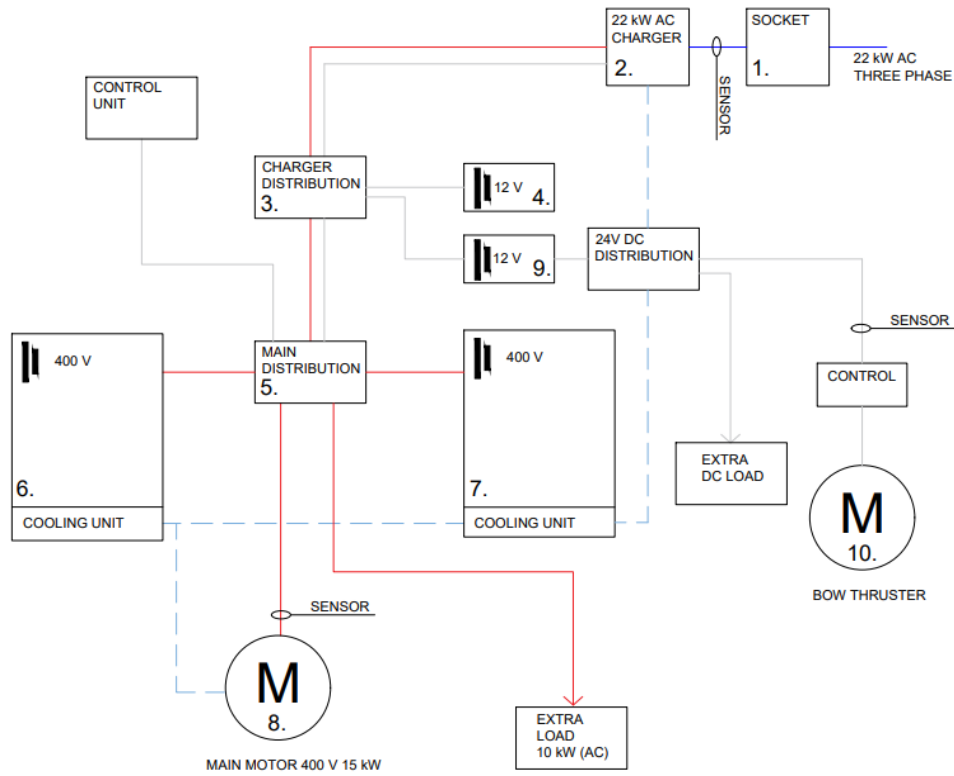
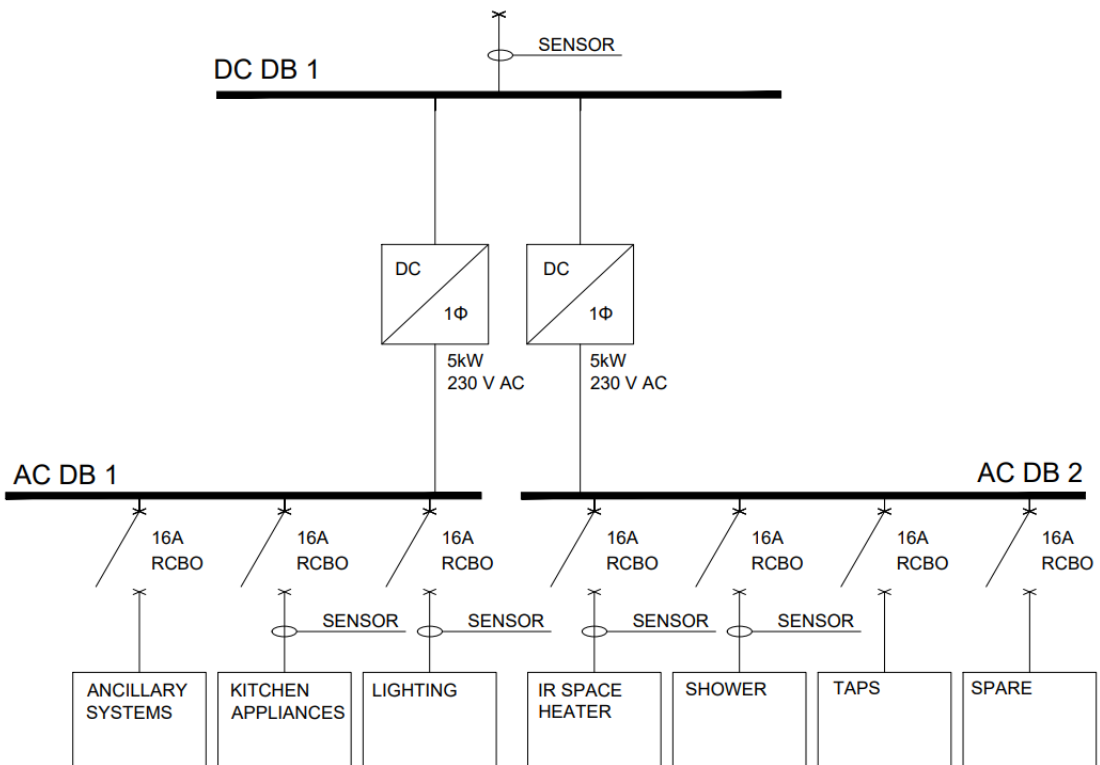

Figure A4.2: AC distribution system and loads



## Principal component list

Components are identified by item number in Table A4.1 below, which include the numbering of components in Figure A4.1, above and Figure A4.3. below.

<b>Table A4.1: Principal component list for proposed demonstration vessel retrofit (Boat 1)</b>				
<b>Item Number</b>	<b>Item description</b>	<b>QTY</b>	<b>Supplier</b>	<b>Lead time</b>
1	Socket	1	Mennekes	1 week
2	Onboard charger 22kW	1	Torqueedo	6-8 weeks
3	Charger distribution Box	1	Torqueedo	6-8 weeks
4	12V Starter Battery	1	Various	1-2 weeks
5	Main distribution box/system management unit	1	Torqueedo	6-8 weeks
6	Battery System 40 kWh with cooling and venting kit	1	Torqueedo	6-8 weeks
7	Battery System 40 kWh with cooling and venting kit	1	Torqueedo	6-8 weeks
8	Main Propulsion Motor	1	Torqueedo	6-8 weeks
9	12V Battery System	1	Various	1-2 weeks
10	Sleipner SE 80 Bow Thruster Motor System	1	Ar Peachment	3 weeks
<b>Additional electrical items</b>				
N/A	Extra load AC Distribution, Inverters and distribution boards	1	Various	2-3 weeks
N/A	Cabling	1	Various	1-2 weeks
N/A	Cooling systems	1	Various	2-3 weeks
N/A	Infrared comfort heaters & thermostats	3	Infra Sols	2-3 weeks
N/A	Controls for principal electrical systems (propulsion, bow thruster, IR heaters etc)	3+	As per manufacturer	2-3 weeks
N/A	Instant hot water taps	4	Sagittarius	1 week
N/A	Instant hot water shower assembly	3	TBD	2-3 weeks
N/A	Data logger, sensors and cabling to facilitate data collection	10+	TBD	2-3 weeks
<b>Additional mechanical items</b>				
N/A	Propeller and propeller shaft assembly	1	Michigan/Torqueedo	4 weeks
<b>Additional labour items</b>				
N/A	Installation labour	1	NBD	-

N/A	Installation labour/commissioning and further design	1	Torqueedo	-
-----	--	---	-----------	---

Figure A4.3: Layout of powertrain DC components

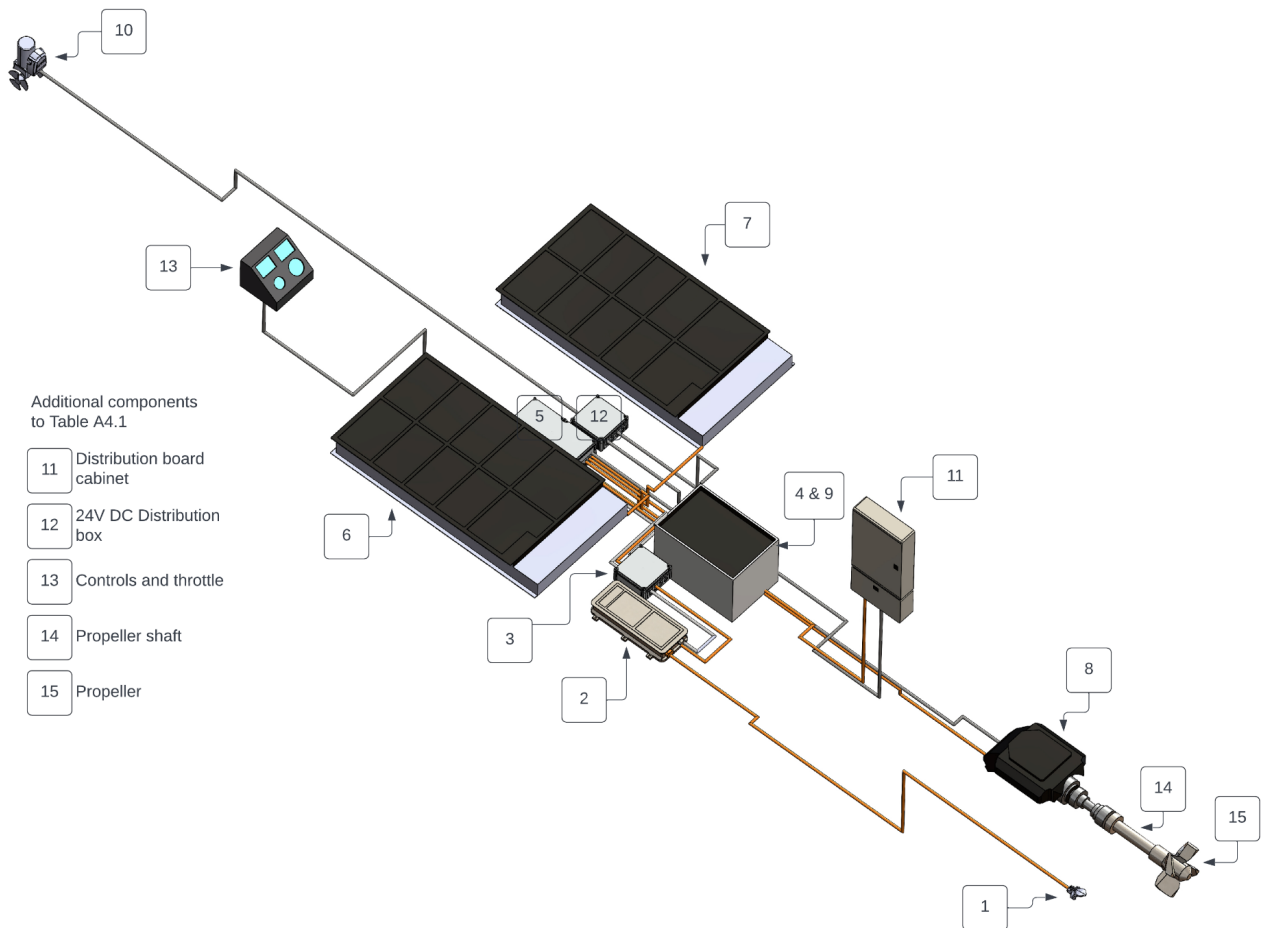

### 3D impressions of proposed retrofit design

In Figure A4.4 and A4.5 we present how we envisage the powertrain integrating within the retrofit President class vessel.

Figure A4.4: Plan view of retrofit vessel with powertrain components

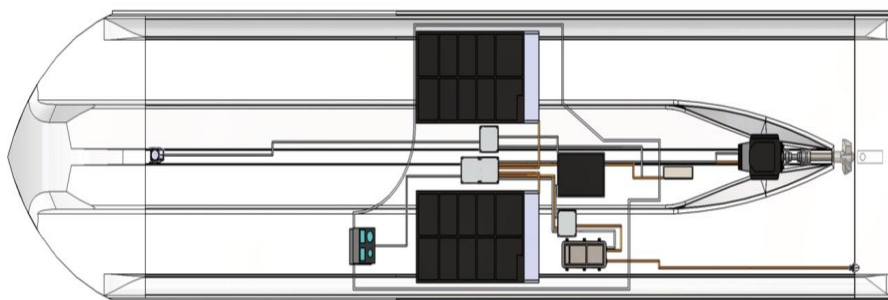
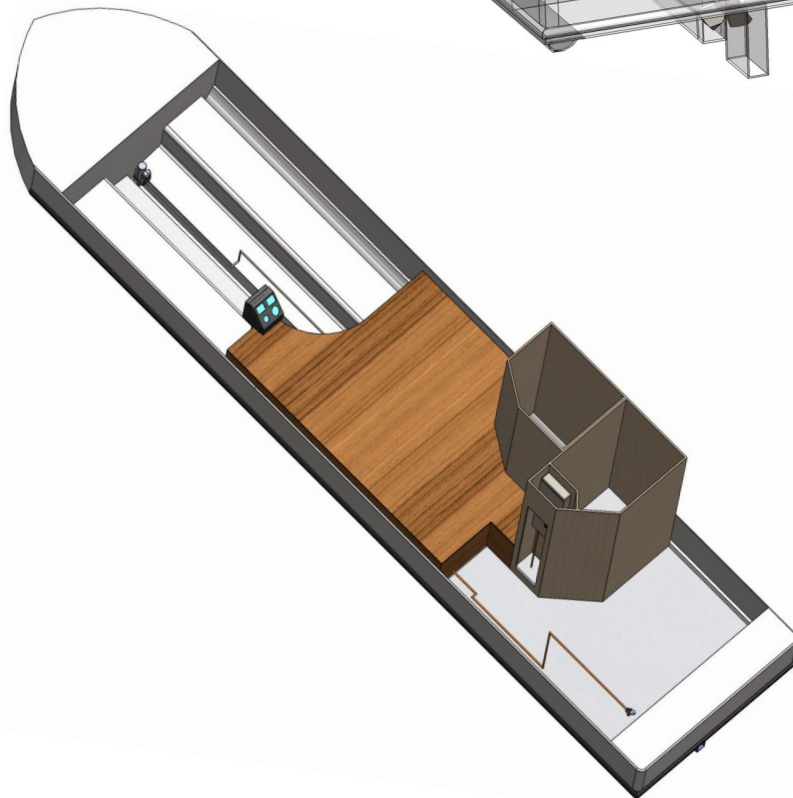
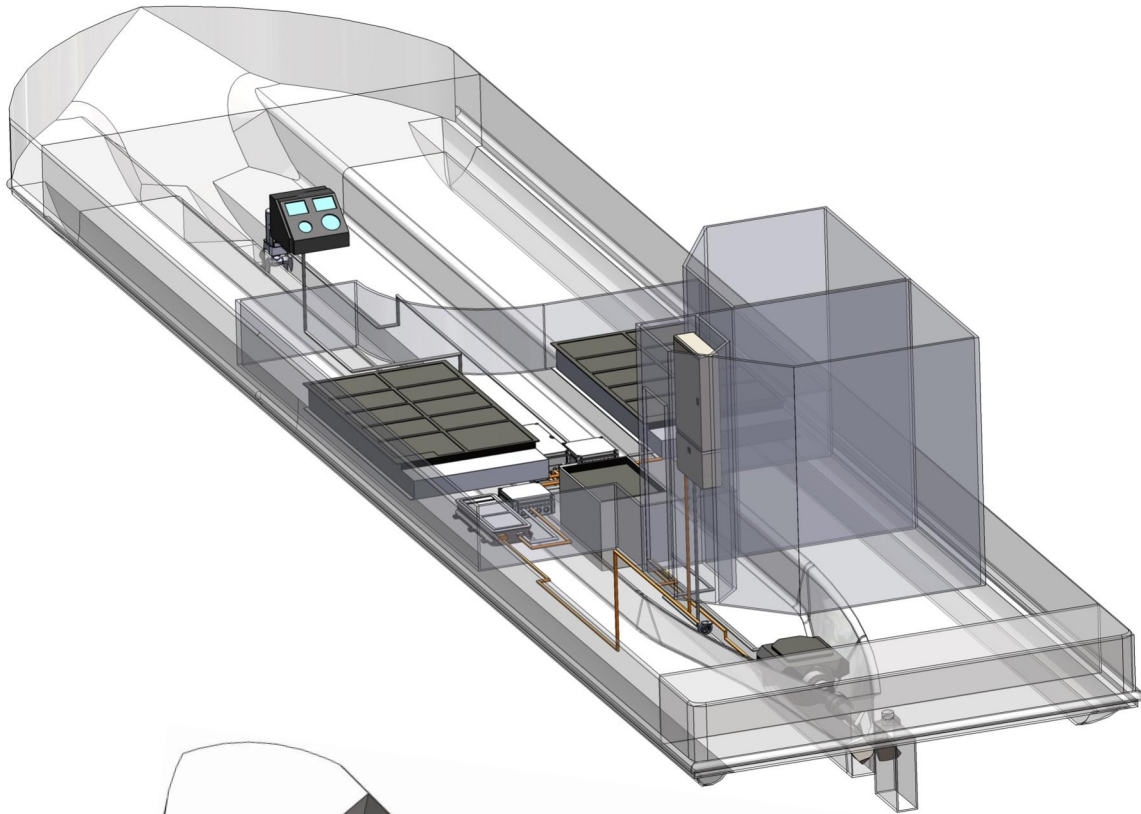

Figure A4.5: Powertrain layout within retrofit vessel and enclosing superstructure



### Boat 2 design approach

The powertrain of the second approach we researched involved the use of a different range of off-the-shelf components based around a single Kreisel 63kWh battery system and Bellmarine propulsion equipment. However the detail of the DC-DC voltage management was yet to be confirmed as it would require a bespoke solution to step down from the battery voltage (nominally 400V) to the motor voltage (96V). The critical issue in this challenge is the capacity of the power electronics to handle full throttle power demand from a 10-15kW motor. The detail of the design is presented below for reference and is not our choice for the demonstration vessel at the time of writing. Other components relating to provision of space heating and hot water are common with the Boat 1 design.

Figure A4.3 'Boat 2' powertrain electrical schematic

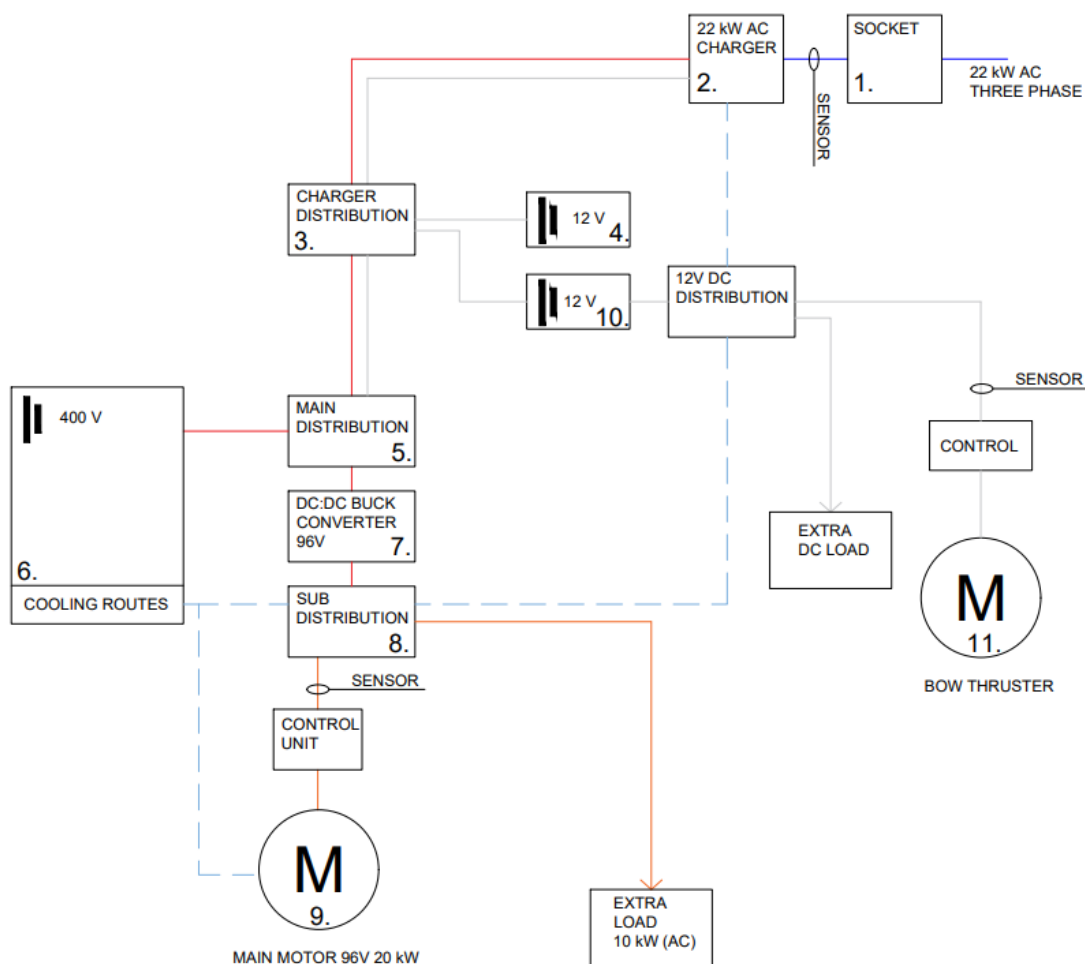

## Boat 2 principal component list

The numbered components from the design approach in Figure A4.3 are listed below in Table A4.2.

<b>Table A4.2: Principal component list for secondary solution to demonstration vessel (Boat 2)</b>				
<b>Item Number</b>	<b>Item description</b>	<b>QTY</b>	<b>Supplier</b>	<b>Lead time</b>
1	Socket	1	Mennekes	1 week
2	Onboard charger 22kW	1	Kreisel	8-10 weeks
3	Charger distribution Box	1	Kreisel	8-10 weeks
4	12V Starter Battery	1	Various	1-2 weeks
5	Main distribution box	1	Kreisel	8-10 weeks
6	Battery System 63 kWh with cooling and venting kit	1	Kreisel	8-10 weeks
7	30kW Buck Converter 400V – 96V DC	1	Tame Power	12 weeks
8	Sub distribution box	1	Bellmarine/ Fisher Panda	6-8 weeks
9	Main Propulsion Motor 20kW	1	Bellmarine/ Fisher Panda	6-8 weeks
10	12V Battery System	1	Various	1-2 weeks
11	Bow Thruster Motor System	1	Ar Peachment	3 weeks
<b>Additional items</b>				
N/A	Extra load AC Distribution, Inverters and distribution boards	1	Various	2-3 weeks
N/A	Cabling	1	Various	1-2 weeks
N/A	Cooling systems	1	Various	2-3 weeks
N/A	Infrared comfort heaters & thermostats	3	Infra Sols	2-3 weeks
N/A	Installation labour	1	Nbd	-
N/A	Installation labour/commissioning and further design	1	Kreisel	-

## Appendix 5 - The electricity distribution network serving the Broads

### The electricity distribution network serving the Broads

When considering a programme of electrification, it is essential to understand the opportunities and challenges presented by the local electricity network. In the Eastern region, the Distribution Network Operator (DNO) is UK Power Networks (UKPN) - see Figure A5.1, below.

**Figure A5.1: The Broads segmented for analysis**

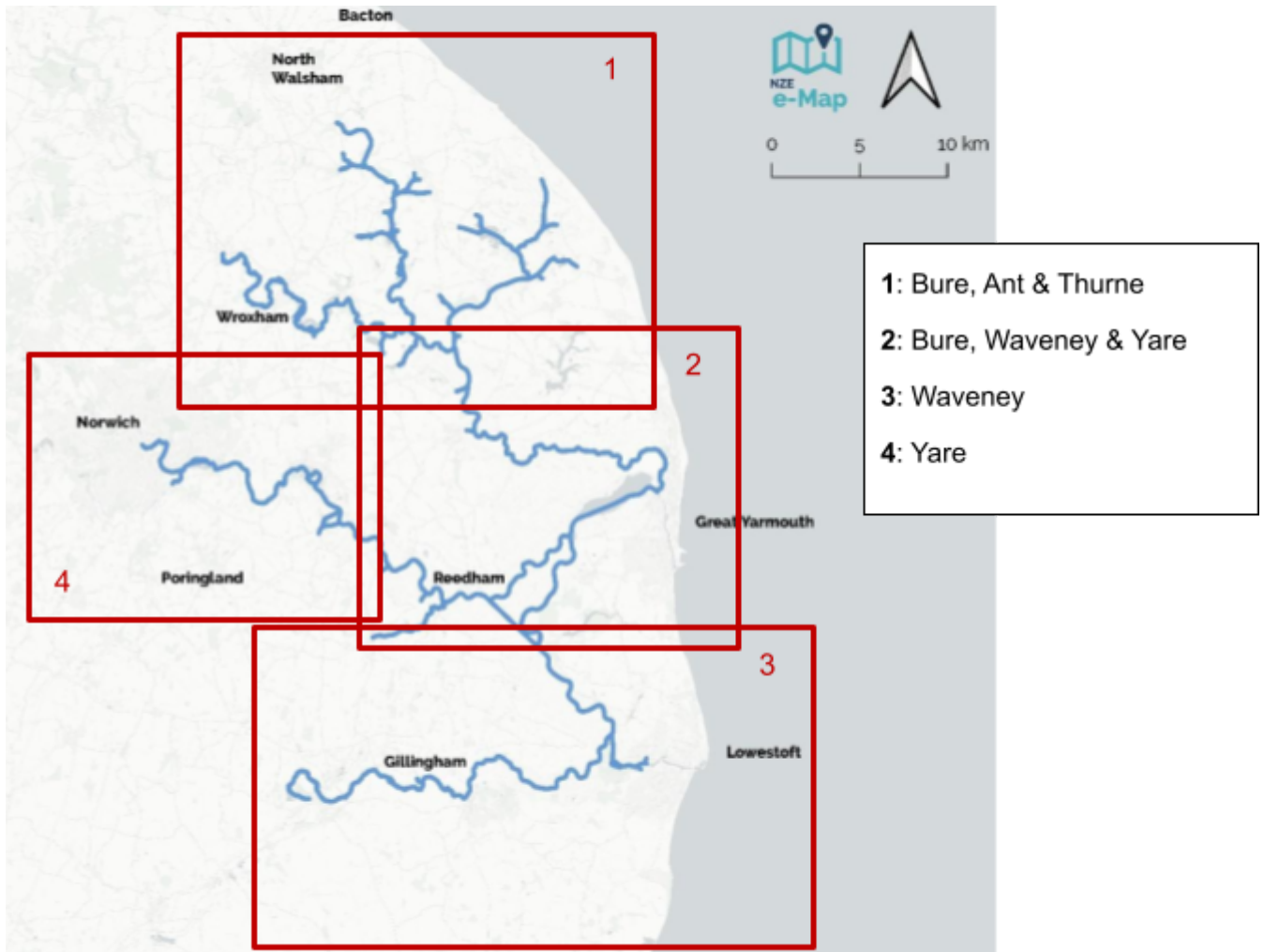

## Electricity distribution cables

The electricity distribution network is present at varying voltages across the Broads up to 132kV. The majority of infrastructure is at 11kV or below, but there are some key higher voltage cables (largely at 33kV) crossing at key points. Figures A5.1 and A5.2, and Table A5.1 show the distribution of the physical electricity network across the Broads, split into four segments for ease of analysis.

There are also lines below the 6.6kV level connecting into local homes and businesses, but visibility of this infrastructure for the entire Broads project area is not currently readily available. Priority sites for implementing charging infrastructure should therefore be examined through direct engagement with UKPN to achieve a further level of granularity.

**Table A5.1: Summary of notable electricity network cables**

Section 1	<ul style="list-style-type: none"> <li>● There is no presence of 132kV cables in Section 1</li> <li>● North Walsham is a key connection point for the some of the region’s extra-high voltage 33kV cables</li> <li>● There is presence of extra-high voltage 33kV cables crossing at, and adjacent to, key sections of the Broads including:               <ul style="list-style-type: none"> <li>○ <b>North Walsham &amp; Dilham Canal:</b> south of Honing and north of Wayford</li> <li>○ <b>River Ant:</b> east of river through to Bure confluence</li> <li>○ <b>River Bure:</b> At Hoveton adjacent to railway bridge, south of Ludham and north-east of South Walsham</li> <li>○ <b>River Thurne:</b> There is a nearby 33kV cable south-east of Martham</li> </ul> </li> </ul>
Section 2	<ul style="list-style-type: none"> <li>● There are 132kV cables present in Section 2, linking Great Yarmouth with Norwich, including:               <ul style="list-style-type: none"> <li>○ <b>River Waveney and New Cut Dyke:</b> crossing just north-west of St Olaves</li> <li>○ <b>River Chet:</b> north-west of Heckingham</li> </ul> </li> <li>● The 33kV cables present here are those West of Acle and crossing at the River Bure (see section 1)</li> </ul>
Section 3	<ul style="list-style-type: none"> <li>● There are 132kV electricity cables present in Section 3, including:               <ul style="list-style-type: none"> <li>○ <b>River Waveney:</b> east of the Broads with a major 132kV cable linking Great Yarmouth with Lowestoft and, crossing the river south-west of Gillingham</li> </ul> </li> <li>● There are 33kV lines present in the region including at:               <ul style="list-style-type: none"> <li>○ <b>River Waveney:</b> east of the Broads, parallel to the Great Yarmouth-Lowestoft 132kV link</li> <li>○ <b>River Yare:</b> Along the south of the river, stretching from Lowestoft to Bungay</li> </ul> </li> </ul>
Section 4	<ul style="list-style-type: none"> <li>● There are major 132kV cables present in Section 4 given the proximity of this part of the Broads to the city of Norwich, including at:               <ul style="list-style-type: none"> <li>○ <b>River Yare:</b> Along the south of the river linking through to Bungay and Lowestoft, and crossing the river east of the Trowse Bridge in the East of Norwich</li> </ul> </li> <li>● There is an abundance of 33kV electricity cables in the region, including:               <ul style="list-style-type: none"> <li>○ <b>River Yare:</b> north of the river linking Norwich with Postwick and further afield to Lingwood, south of the river connecting Norwich with Yelverton and, crossing the river parallel to the 132kV link</li> </ul> </li> </ul>

Figure A5.2: The electricity network across the Broads

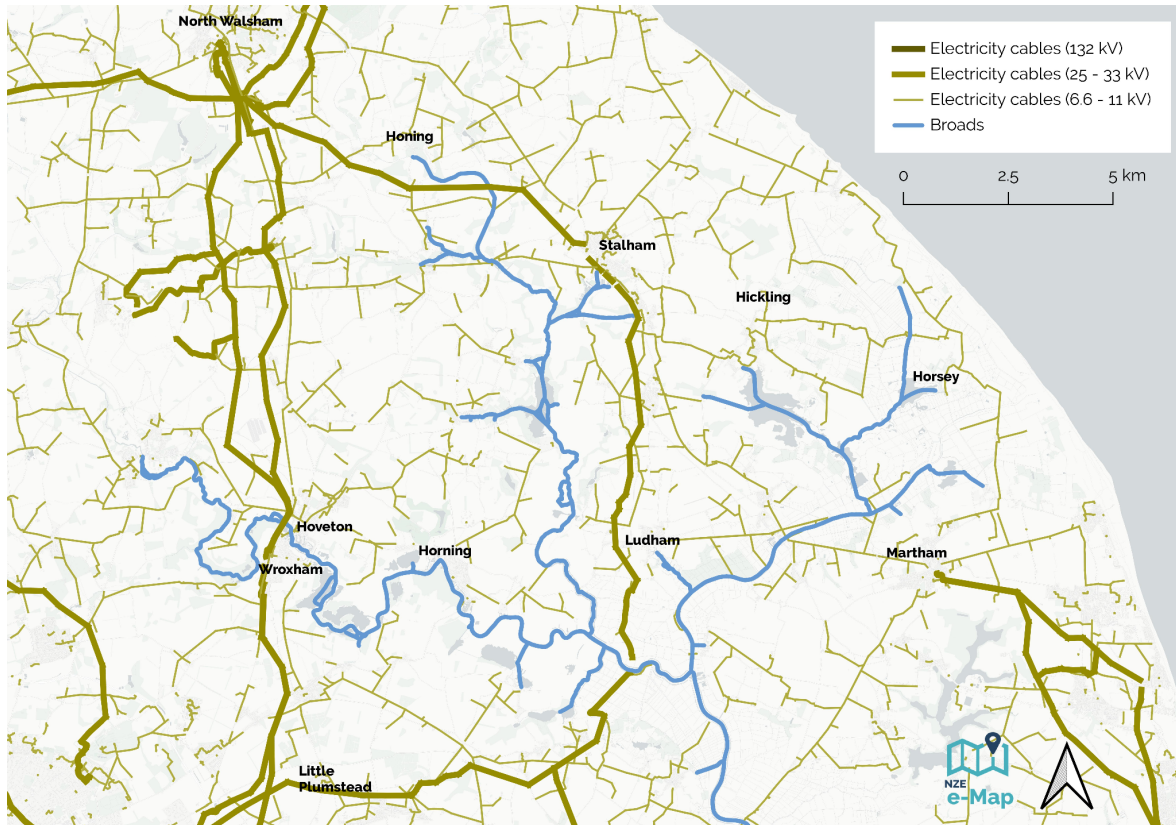

1

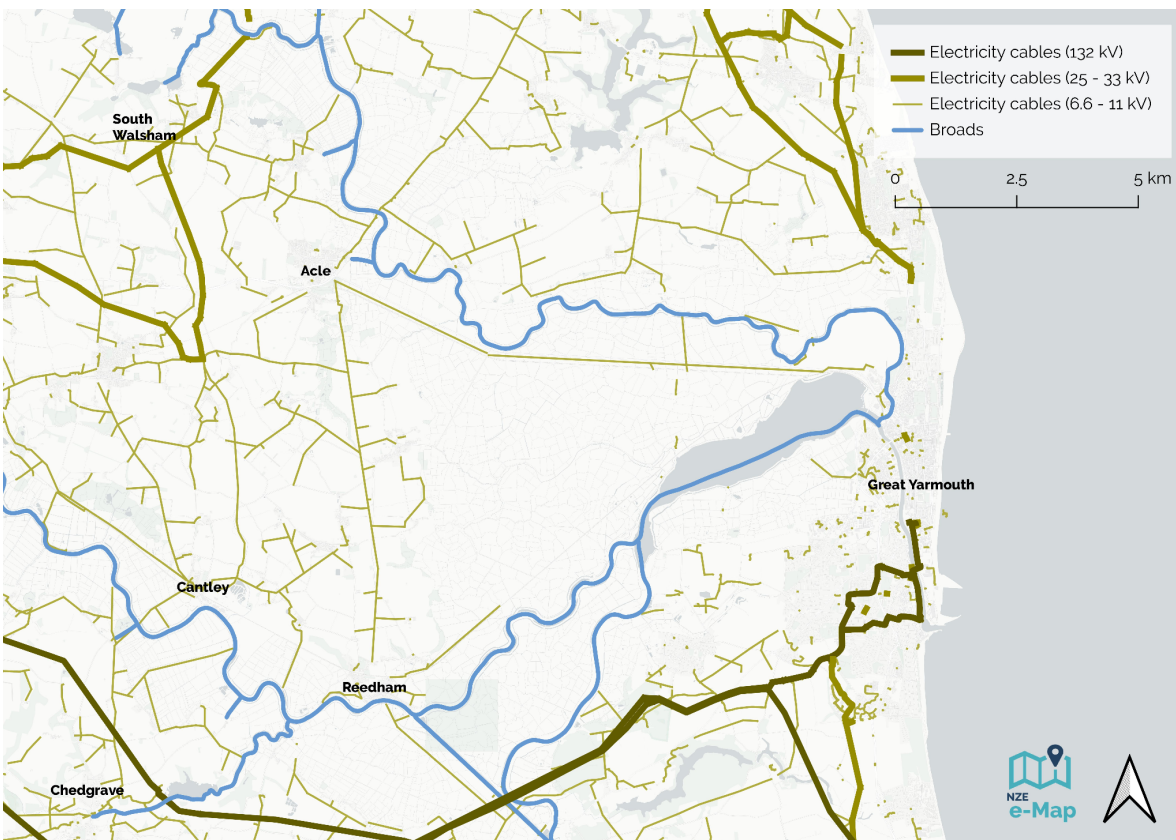

2

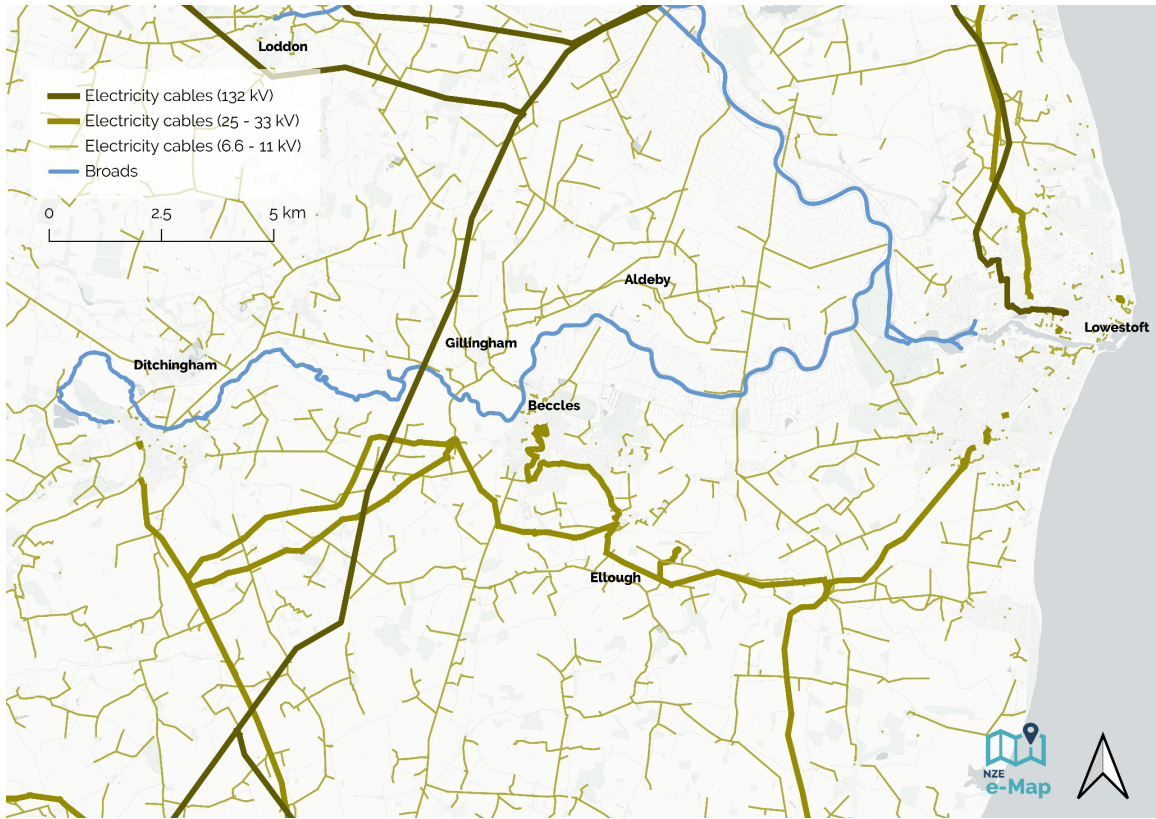

3

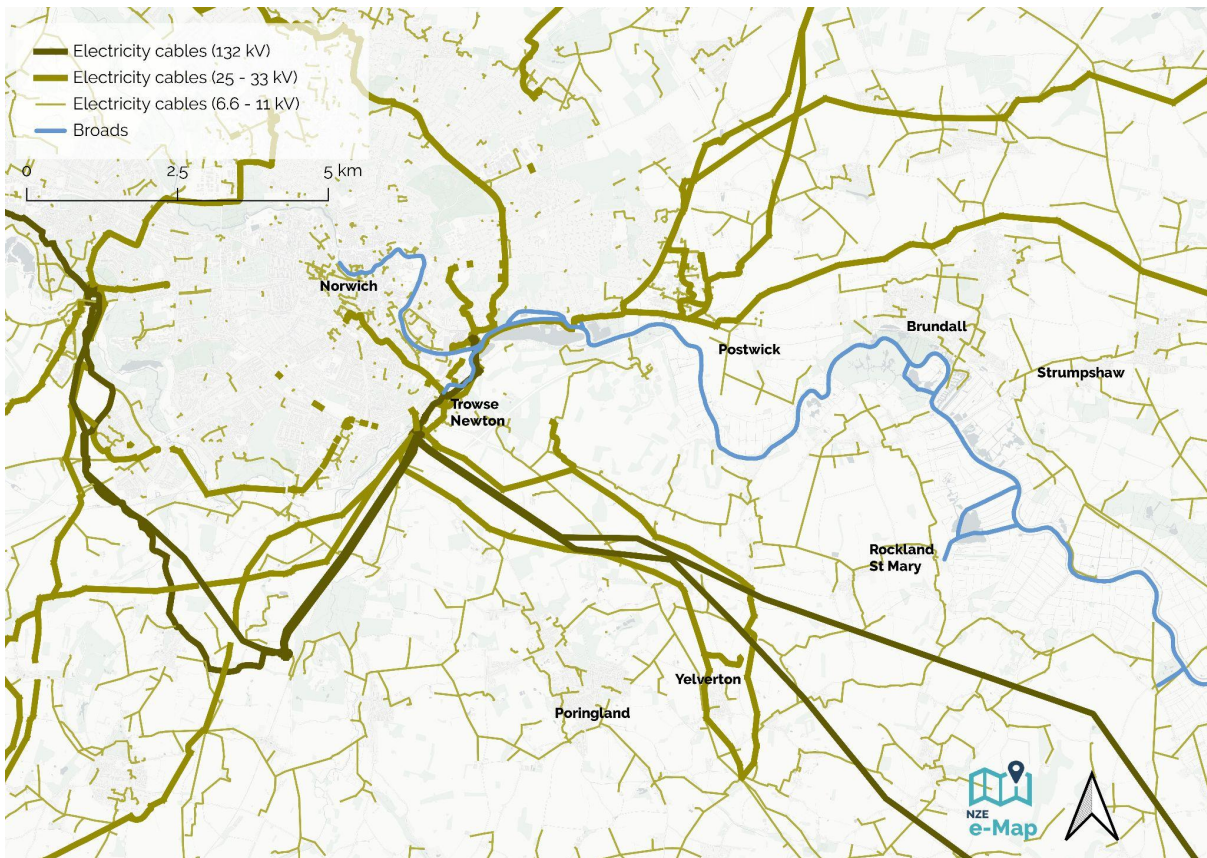

4

### Electricity network constraints

The electricity network across the entire New Anglia (Norfolk and Suffolk) region is significantly constrained, meaning that it can be difficult to secure new connections, or there may be restrictions on terms of connection. The majority of the Broads region falls within a flexible distributed generation zone. In practice, this allows UKPN to accept new generation connections on to the grid above unconstrained connection limits. Generators can be connected faster and often at lower costs but, through Active Network Management (ANM), they can be curtailed or ‘turned down’ during sporadic constraint events. Generators most recently connected will be first to be curtailed in application of ANM.

In addition, southern sections of the Broads, largely around the River Waveney, see the higher voltage 132kV distribution and 400kV transmission networks highly utilised. This is largely a result of significant renewable generation connecting from offshore, with 3.4GW of offshore wind currently connecting into Norfolk and Suffolk networks. With an additional 10GW in planning and expected to come online by 2030, infrastructure constraints across the New Anglia region are likely to persist.

In order to obtain visibility of constraints at the local level along the Broads network, indicative substation headroom can be examined. Substation headroom provides a signal for the amount of new generation (generation headroom) or demand (demand headroom) that can be connected into the local substation area without requiring significant grid reinforcement. See Figure A5.3, below.

**Figure A5.3: 132kV substations within two miles of the Broads, with indicative headroom (MW)**

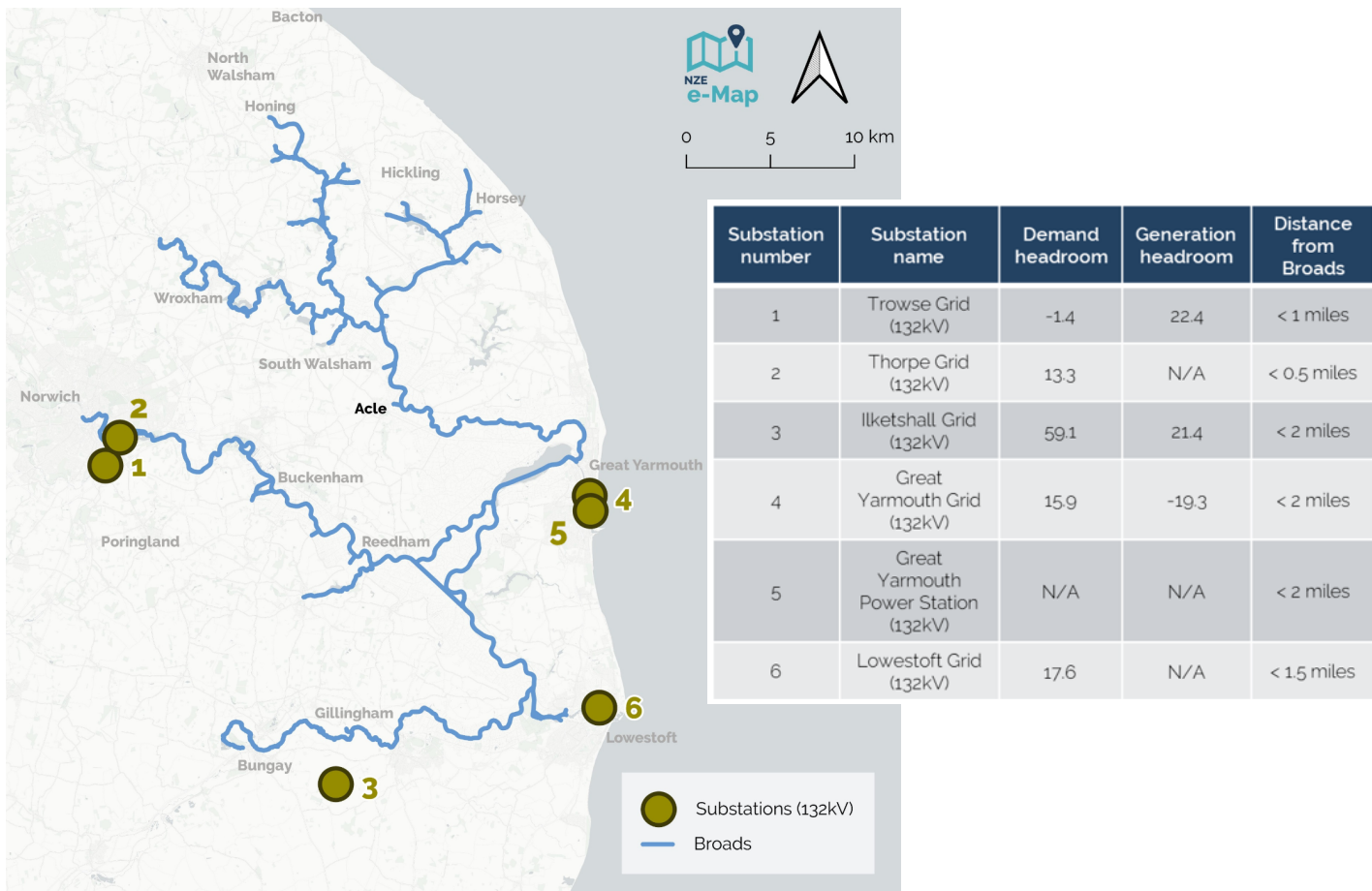

In the Broads region, there are a number of substations with available demand and generation headroom. Figure A5.3 shows the 132kV substations within two miles of the Broads network and indicative headroom values. Of these, substations 2-4 and 5 have indicative demand headroom of more than 13MW. This suggests that there may be capacity to connect new charging points at sections along the Broads in close proximity to these substations, namely east of Norwich along the River Yare, west of Lowestoft at Oulton Broad and along the River Waveney, south of Gillingham.

Substations with estimated generation headroom include 1 and 3, each with more than 20MW potentially available. In the case that there is a suitable site nearby, connecting in new solar PV here could also be used to power electric charging points along the Broads on the east of Norwich and south of Gillingham. Generation data on other substations in the region is not available. This may be due to the absence of generation currently connected in, and so does not necessarily mean that new generation developments would be inhibited.

It should be noted that there is an absence of larger capacity substations in the northern sections of the Broads, and centrally in the vicinity of Reedham. The electricity network in these parts is typically lower voltage and therefore less able to take significant new charging infrastructure or generation.

In order to obtain a more local visibility of these parts of the network, it is possible to examine headroom at the 33kV substation level. This can give an indication of what capacity can potentially physically connect into the 33kV substations but also a broad sense for general constraints in that substation supply area. Figure A5.4 shows the substations at this level along the four allocated sections of the Broads. A summary of substation headroom at each of the four sections along the Broads is as follows in Table A5.2.

Demand and generation data on 11kV substations is not made available by UKPN across its entire network, but expected headroom may be inferred based on the area’s higher voltage substations (i.e., at 33kV). This should be taken to be purely indicative. In Section 5.3.1 of this study, priority sites will be identified which can then be taken to UKPN to obtain more granular information at the lower voltage level at relevant locations.

**Table A5.2: Summary of notable electricity substations at 33kV**

<p><b>Section 1</b></p>	<ul style="list-style-type: none"> <li>● There are four 33kV substations in this region</li> <li>● The substations are distributed across Section 1 with two along the River Bure and one along the River Ant and River Thurne respectively</li> <li>● There is expected demand headroom at substations 2 (4.0MW), 3 (11.1MW) and 4 (3.9MW) with values not available for substation 1</li> <li>● Visibility of generation headroom is only available at substation 4, and expected to be up to 5.0MW</li> </ul>
<p><b>Section 2</b></p>	<ul style="list-style-type: none"> <li>● There are three 33kV substations in Section 2</li> <li>● The substations all serve the town of Great Yarmouth and surrounding regions</li> <li>● Demand headroom is only available at substation 3 here which has up to 14.6MW available</li> <li>● In respect of generation headroom, substation 1 is expected to have up to 9.6MW available. Data is not available for substations 2 and 3.</li> </ul>
<p><b>Section 3</b></p>	<ul style="list-style-type: none"> <li>● There are six 33kV substations in Section 3</li> <li>● The substations are all in relatively close proximity to the Broads system (within 0.5-1 mile) and so should give a good reflection of capacity locally</li> <li>● There is up to 5.0MW of demand headroom at substations 2 (1.8MW), 3 (3.6MW) and 5 (4.9MW)</li> <li>● There is up to 10.0MW of demand headroom at substations 1 (6.7MW) and 6 (9.0MW)</li> <li>● In respect of generation headroom, there is anticipated headroom at substations 2 (4.6MW) and 3 (8.0MW) which sit in close proximity to each other at Beccles, south of the River Waveney.</li> </ul>

<b>Section 4</b>	<ul style="list-style-type: none"><li>● There are eleven substations in the Section 4 region which serve the City of Norwich and surrounding suburbs</li><li>● Two substations have up to 5.0MW of demand headroom. These are substation 5 (4.0MW) and 10 (2.5MW) which largely serve local residential demands</li><li>● An additional five substations have between 5.0MW and 10.0MW of demand headroom. These are substations 1 (6.1MW), 2 (5.7MW), 3 (7.0MW), 4 (9.3MW) and 6 (9.7MW)</li><li>● There are a further two substations which have greater than 10.0MW of demand headroom. These are substations 9 (34.3MW) and 11 (11.7MW).</li><li>● Significant demand headroom in this region is likely to make it a feasible location for installing electric charging points</li><li>● In respect of generation headroom, visibility is only available at substation 2 which is expected to have up to 15.0MW.</li></ul>
------------------	--

Figure A5.4: 33kV substations and headroom estimates

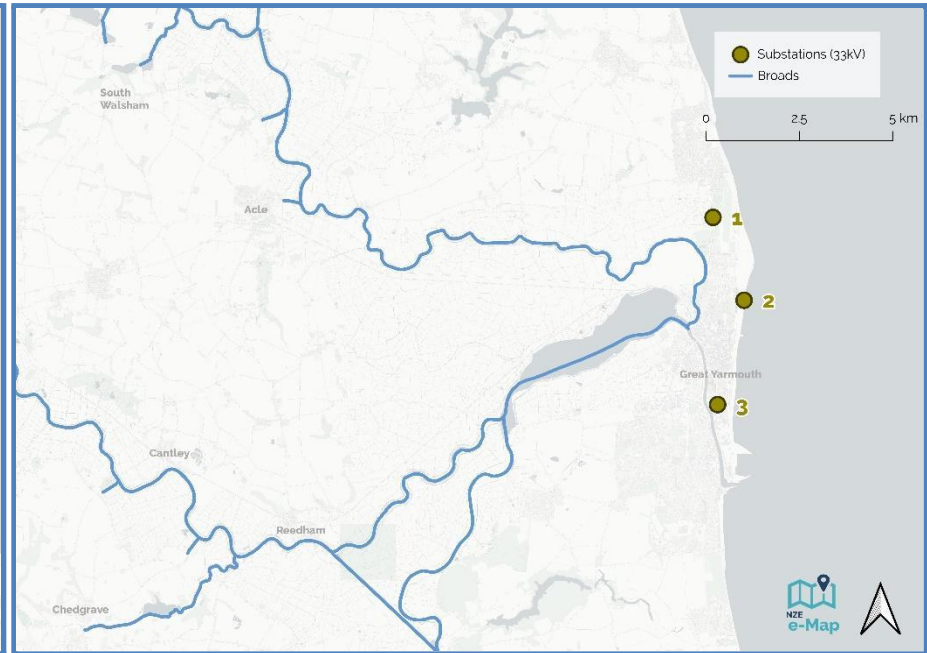
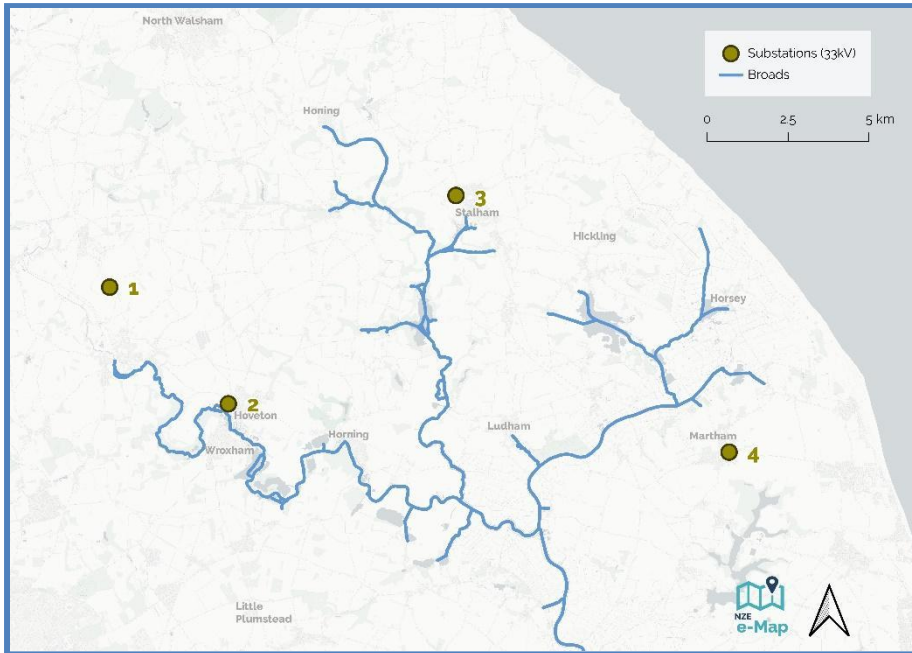

Substation number	Substation name	Demand headroom	Generation headroom	Distance from Broads
1	Scottow Est Solar Farm (33kV)	N/A	N/A	< 1.5 miles
2	Wroxham Primary (33kV)	4.0 MW	N/A	< 0.5 miles
3	Stalham Primary (33kV)	11.1 MW	N/A	< 0.5 miles
4	Martham Primary (33kV)	3.9 MW	5.0 MW	< 1.5 miles

Substation number	Substation name	Demand headroom	Generation headroom	Distance from Broads
1	Caister Primary (33kV)	-0.1 MW	9.6 MW	< 1 miles
2	Scroby Sands Wind Farm (33kV)	N/A	N/A	< 1 miles
3	Great Yarmouth Grid (33kV)	14.6 MW	N/A	< 1.5 miles

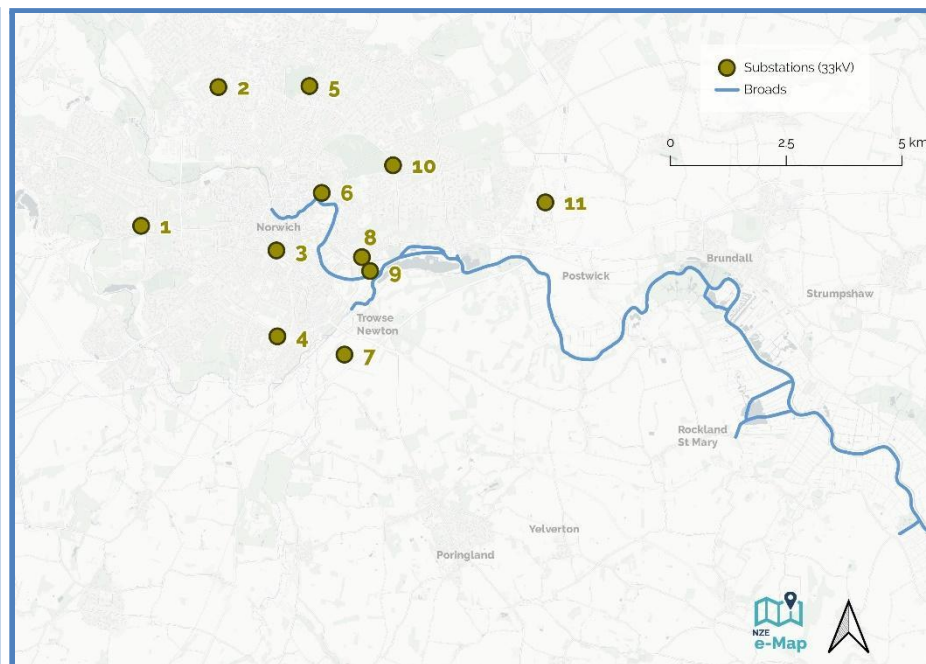

Substation number	Substation name	Demand headroom	Generation headroom	Distance from Broads
1	Bungay Primary (33kV)	6.7 MW	N/A	< 0.5 miles
2	Barsham Primary (33kV)	1.8 MW	4.6 MW	< 1 miles
3	Beccles Primary (33kV)	3.6 MW	8.0 MW	< 0.5 miles
4	Beccles Primary Playter DNO (33kV)	N/A	N/A	< 0.5 miles
5	Long Road Primary (33kV)	4.9 MW	N/A	< 0.5 miles
6	Lowestoft Grid (33kV)	9.0 MW	N/A	< 0.5 miles

Substation number	Substation name	Demand headroom	Generation headroom	Distance from Broads
1	Earham West Primary (33kV)	6.1	0	< 2 miles
2	Boundary Park Primary (33kV)	5.7	15	< 2 miles
3	St Stephens Primary (33kV)	7	N/A	< 0.5 miles
4	Tuckswood Primary (33kV)	9.3	N/A	< 1.5 miles
5	George Hill Primary (33kV)	4	N/A	< 2 miles
6	Barrack St Primary (33kV)	9.7	N/A	< 0.5 miles
7	Trowse Solar Farm (33kV)	N/A	N/A	< 1 miles
8	Lse Primary (33kV)	N/A	N/A	< 0.5 miles
9	Thorpe Local Switching Station (33kV)	34.3	0	< 0.5 miles
10	Mousehold Primary (33kV)	2.5	N/A	< 1.5 miles
11	Peachman Way Primary (33kV)	11.7	0	< 1 miles

## Alternatives to grid-connected charge points considered for future demonstration

It is the starting assertion of this project that the provision of shoreside charging points is the most logical pathway to providing infrastructure for electric vessels. Given the constraints on the electricity network, as well as sensitivities around the natural environment of the Broads, alternatives to grid-connected charges will be evaluated where needed. We provisionally list these below:

### Off-grid renewables

In order for this to be viable, due to the intermittent nature of renewables, energy would need to be stored – most likely through a co-located battery. Multi-use chargers servicing cars and boats will also improve the sustainability of the system. Energy would then be discharged to vessels via ECPs when required.

As the number of boats increases, the need for additional grid support will become important in sustaining a serviceable fleet. There are two main approaches to supporting a local grid.

- Support with renewable generation (Solar PV)
- Support with energy storage (Battery)

This would avoid the need for spare network capacity, and avoid the associated costs of securing a network connection. An indicative design provided by Freqcon on how a future solution may look is presented in Figure A5.5, below. The current development of battery storage and DC:DC charging means that commercial viability of this aspect of this design would only make sense as the demand is required or grid support is no longer practical. However, renewable energy generation solutions are now available which are both commercially viable and attractive.

Figure A5.5: Boatyard solar augmented dual purpose EV/MEV charging station



Technical specifications of the above example provided by Freqcon<sup>74</sup> are presented in Table A5.3, below.

<sup>74</sup> <https://www.freqcon.com>

**Table A5.3: Range of dual purpose charging stations offered by Freqcon.**

Technical Data	Standard Sizes			
	FRQ-FCS-800-20HC	FRQ-FCS-1250-20HC	FRQ-FCS-1500-30HC	FRQ-FCS-2830-40HC
<b>DC Charging Station Specification</b>				
Maximum combined DC Power Output	800 kW (DC)	1250 kW (DC)	1500 kW (DC)	2830 kW (DC)
Number of DC chargers per Station	6	5	8	10
Maximum DC Output Power each Charger	150 kW	300 kW	2 x 300 kW & 6 x 150 kW	300 kW
Maximum DC Output Current each Charger	250 A	500 A	500 A / 250 A	500 A
Output DC Voltage Range	150 V <sub>DC</sub> to 1000 V <sub>DC</sub>	150 V <sub>DC</sub> to 1000 V <sub>DC</sub>	150 V <sub>DC</sub> to 1000 V <sub>DC</sub>	150 V <sub>DC</sub> to 1000 V <sub>DC</sub>
DC-connection standard	CCS-2 up to 250 A CHAdeMO up to 200 A (optional)	CCS-2 up to 500 A CHAdeMO up to 200 A (optional)	CCS-2 up to 500 A CHAdeMO up to 200 A (optional)	CCS-2 up to 500 A CHAdeMO up to 200 A (optional)
Battery Storage Type	BESS FQ 500 (LFP)	BESS FQ 1000 (LFP)	BESS FQ 2000 (LFP)	BESS FQ 2500 (LFP)
Battery Capacity (installed)	500 kWh	1000 kWh	2000 kWh	2500 kWh
Battery Capacity (useable)	450 kWh	900 kWh	1800 kWh	2250 kWh
Battery Cells	EVE LF280K	EVE LF280K	EVE LF280K	EVE LF280K
Battery Cycles at 0.5 C / 1 C	≥ 6000 / 4500 cycles at 80% EoL			
Battery Converter DC Output Power	450 kW	900 kW	1500 kW	2200 kW
<b>Grid</b>				
FREQCON Power Converter	MSC 380-400-X	MSC 380-400-X	MSC 380-400-X	MSC 750-400-X
AC Input Power (from PowerGrid)	350 kVA (at 800 kW DC Output Power)	350 kVA (at 1250 kW DC Output Power)	350 kVA (at 1500 kW DC Output Power)	630 kVA (at 2830 kW DC Output Power)
AC Input Voltages	400 V <sub>AC</sub> 620 V <sub>AC</sub> (optional)			
Max. AC Input Current	525 A			1050 A
Number of DC Outputs	8 (2 x 500 A <sub>DC</sub> + 6 x 250 A <sub>DC</sub> )	9 (9 x 500 A <sub>DC</sub> )	11 (5 x 500 A <sub>DC</sub> + 6 x 250 A <sub>DC</sub> )	13 (10 x 500 A <sub>DC</sub> + 3 x 1000 A <sub>DC</sub> )
AC Power Frequency (range)	50 Hz (47 Hz to 53 Hz)			
IGBT Switching Frequency	2 to 4 kHz			
Power Factor at Rated Power / Adjustable	1 / 0.03 overexcited to 0.00 underexcited			
Grounding System Type	IT system			

A similar solution (with non-grid tied optionality) would comprise a solar carport and static battery that could be connected to a range of ECPs (see Figure A5.6, below). Indicative statistics for this solution are presented in Table A5.4.

**Table A5.4: Indicative statistics for a renewable energy solution powering ECPs**

<b>PV System</b>	
PV Generator Output	53.82 kWp
Spec. Annual Yield	982.24 kWh/kWp
Performance Ratio (PR)	92.05 %
Yield Reduction due to Shading	0.7 %/Year
<b>Grid Feed-in</b>	
Grid Feed-in	52,886 kWh/Year
Grid Feed-in in the first year (incl. module degradation)	52,144 kWh/Year
Standby Consumption (Inverter)	22 kWh/Year
CO <sub>2</sub> Emissions avoided	14,802 kg / year

Figure A5.6: Solar canopy and static battery offering a renewable energy solution to ECP electricity supply.



Indicative costs of a hybrid charging solution from the above approaches are presented in Table A5.5, below.

<b>Table A5.5: Indicative costs of hybrid renewable energy charging solution</b>					
<b>Item Number</b>	<b>Item description</b>	<b>QTY</b>	<b>Supplier</b>	<b>Approximate cost</b>	<b>Lead time</b>
1	Solar Canopy and Installation (50kWp)	1	RenEnergy	£76,000	6-8 weeks
2	FRQ-FCS-800 6 x 150kW DC chargers and 800kW - 500kWh Battery system	1	Freqcon	£400,000	9 months
<b>SUB TOTAL</b>				<b>£476,450</b>	<b>9 months</b>
<b>OPTIONAL COSTS</b>					
N/A	E-STOR 300kW – 360kWh	1	Connected Energy	£70,000	6 months

*Charging barges*

An alternative proposition is to see boats mooring at barges hosting batteries which can allow for remote charging across the region. Barges could recharge at areas of the network under less constraint, and move through sections of the Broads where network-connected electric chargers are more restricted.

*Land-based fuel cells*

This option would see hydrogen or methanol storage tanks on land, linked to a fuel cell which would convert the fuel into electricity for charging. The solution would be free-standing and not require a grid connection but would require the input fuel to be periodically refilled by road or by water depending on storage capacity and charging utilisation.

A number of suppliers such as TCP ECO and Fuel Cell Systems have developed off-grid solutions for fuel cells and could be approached if conventional electric charge points are deemed unviable in certain locations along the Broads.

*Fuel cell electric boats*

This option would see boats refuelling with hydrogen (or ammonia) rather than electricity. The advantages of this include fast refuelling times, avoidance of electricity grid constraints for electric chargers, the ability to travel longer distances on a single re-fuel and lighter on-board fuel storage in comparison with batteries. There are still a number of ‘unknowns’ around hydrogen, with consultations on revenue support and policy frameworks expected to report in early 2022. We will watch for any pertinent announcements on this that could influence hydrogen vessel uptake in the Broads.

During the project, alternative forms of energy storage were considered – especially hydrogen based technologies. In summary, this technology is progressing and is likely to make a significant impact on the transport industry at some point. Currently, commercial viability and availability prohibit the adoption of such technology with the specified demonstrator.

There are elements of the proposed drive system that could be used in the future with a hydrogen fuel cell. As an example an enquiry was made to specify a hydrogen fuel cell to potentially power a future demonstrator vessel as presented in Figure A5.7, below.

**Figure A5.7 Design for a hydrogen fuel cell powered main propulsion system (inset Hydrogen Power Module)<sup>75</sup>**

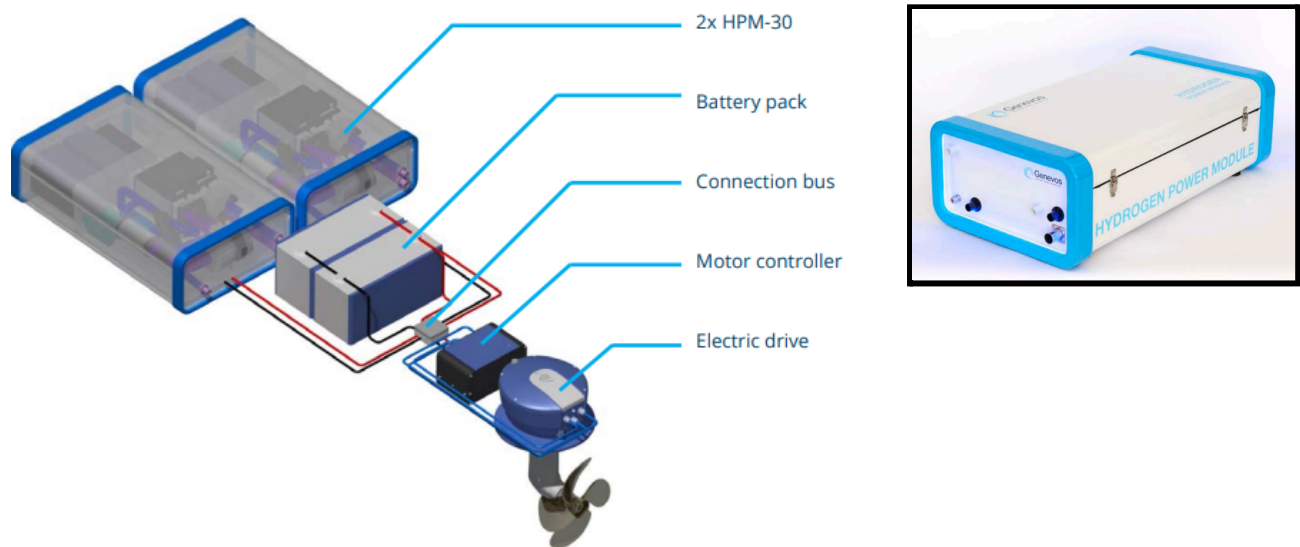

Example: Vessel powertrain with 56 kW HPM propulsion

Some considerations for the design of the fuel cell powertrain include:

<sup>75</sup> Image courtesy of Genevos Ltd.

- The fuel cell will consume a certain amount of H<sub>2</sub> per hour of operations. In order to have maximum efficiency it's better to run the units at 50% or less of their peak. 15KW of output will consume about 1KG of H<sub>2</sub> per hour. It has a relatively linear energy demand.
- Battery Pack: These batteries are there to run in parallel to the fuel cell and to provide a buffer for the unit as it starts and stops. It is important to size the system in order to optimise the operation of the vessel, leveraging the battery storage to cover peaks and smooth the operation of the fuel cell.
- In terms of storage, a 350l tank at 350 bar will store about 7.5kg so you would have about 14 hrs autonomy with 1 tank. The consumption running at 7-8kW would be 0.5kg H<sub>2</sub>/hour.
- A 15kW HPM-15 fuel cell made by Genevos costs approximately £60,000 with a 6 months lead time at the time of writing this report.

This is a design that could be incorporated in an electrically fitted MEV as a substitute for the requirement of batteries and possibly shoreside ECPs. It also signposts the need to resolve the current lack of skills and protocols listed below:

- Installer certification
- Refuelling technique
- Refuelling availability
- Safety aspects

## Appendix 6 - Use cases for charging infrastructure equipment

The objective of the demonstration project will be to confirm that shoreside chargers are suitable for roll-out across the Broads. There are two main factors to be tested;

- Technical viability - that they work correctly with the proposed demonstration described in 5.3
- Operational viability - that they allow people to enjoy the Broads in a way that will be satisfactory to customers, and that they work with the logistical needs of a boatyard.

For the proposed demonstration, the considerations listed in Table A6.1, below, were made to identify the desired charger type and suitable source for a minimum viable charging network.

<b>Table A6.1: Shoreside charging solutions matrix</b>				
<b>Charging Solutions</b>	<b>Characteristics</b>	<b>Constraints</b>	<b>Installation</b>	<b>Issues</b>
E.g. <a href="#">EO Genius chargers</a>	22kW and 7kW AC	Low power grid connection. Use at existing moorings.	1 month	Depends on mooring supply capacity
Charger management system e.g. EO Cloud	Monitors charger status and reports usage etc	Will rely on a communications network. Not specified yet	1 month	May require 3rd party
User management system	Identifies available chargers for mooring and reservation ahead of arrival	Not yet specified. May not be required for demonstration.	1 month	Requires third party system. Operates on mobile phone networks or IoT?
<b>Other charging infrastructure options considered in feasibility study</b>				
<a href="#">Aqua Superpower</a> Ultra-rapid DC-DC MEV chargers	50kW to 350kW DC chargers	High power grid connection	6-9mths	Limited to 3 installations per substation. Not economically attractive for a single vessel demonstration.
<a href="#">Fregcon</a> DER and grid connected multi vehicle charging station	Static battery & 150kW/300kW charger station. MEV to battery possible.	No grid constraints under 350kVA	6-9mths	Too expensive and unnecessary for a single vessel demonstration
<a href="#">Virta</a> Bi-directional charging	Enables two way power flows between the supply side and the vehicle.	Currently emerging solution with few opportunities for grid connection	6-9 months	More planning permissions required for DERs

'Piggy back' network connection to IDB pumping stations	Utilises 100kW IDB connection capacity outside of scheduled pumping requirements	Could facilitate electrical network connection where other options are uneconomical	3 months	Would only work where pumping station is close to mooring ECP and limits to charge availability
---	--	---	----------	---

On the basis of a vessel with a 84.4kWh battery bank, the following two use cases have been identified for charging infrastructure that will be tested in the demonstration project.

#### *Use case 1 - 22kW AC charger*

In order for a boatyard to maximise the potential use/profit from a vessel, it needs to spend as little time as possible in the hire yard. A typical hire pattern is for the boat to be available for departure by the new hirer in the afternoon, after being returned to the yard by the previous hirer in the morning. This will typically leave a 4 hour window to turn the vessel around, and will include any recharging required, alongside cleaning, minor repairs, pumping out the toilets and refilling the water tank.

We have specified a 22kW AC fast charger as sufficient for the Minimum Viable Infrastructure (MVI) as this will be suitable to recharge the 84.4kWh battery bank in 3 to 4 hours.

However, we acknowledge – as the adoption of MEVs develops in future and boatyards will be hiring many MEVs – this means effectively turning around 20-30 boats in a morning. Therefore we anticipate the need to install multiple Rapid DC chargers to recharge all their batteries. Due to the charging characteristics of the batteries, a 50kW DC charger will take about 2 hours to fully charge the 84.4kWh battery bank, as the rate of charge will slow down the closer the battery gets to full with a DC charger.

#### *Use case 2 - 7kW AC Chargers*

As hire cruisers are not allowed to operate at night, they will spend long periods moored at one of the 24 hour moorings dotted around the Broads, generally mooring up by 7pm at night and not departing until around 9am in the morning. This gives a 14 hour window in which to recharge the vessel. A 7kW single phase AC Fast charger should be able to achieve this within 14 hours. As 84kWh is estimated to be more than sufficient energy for a day's cruising in most circumstances, even if the customer is not moored for 14 hours, they should still have enough energy to continue their journey to reach the next mooring charger.

#### *Charger Locations*

For full details of the process of selecting the locations, see the analysis in Appendix 7. In order for there to be a full demonstration of an electric holiday cruiser, there needs to be a network of 7kW chargers creating 'electrical corridors' able to support its progress around the Broads. This would also act as the minimum viable network for other boatyards to start to implement electric boats.

*Future rollout of chargers*

Growth in the adoption of MEVs on the Broads and other inland waterways is very difficult to predict, and will be subject to a range of factors, including:

- Rate of adoption of automotive EVs in the UK
- Legislation or Regulations from authorities
- Availability and relative cost of fuels
- Cost of retrofitting and any government incentives
- Pressure from tourists seeking 'climate-friendly' options
- Visibility of MEVs and infrastructure
- Availability of suitable grid connections

Using the adoption of MEVs estimated in Table 7.15 from section 7.2.7, we estimate the requirement for 7kW fast AC chargers below.

<b>Table A6.2 Projection of hire fleet MEV technology adoption and forecast rollout of charging infrastructure</b>		
<b>Year</b>	<b>Hire fleet MEVs</b>	<b>Number of 7kW MEV Supply Sockets dedicated to the hire fleet</b>
2023	1	8
2024	3	9
2025	6	12
2026	10	20
2027	14	30
2028	20	40
2029	26	60
2030	35	80
2031	48	110
2032	67	140
2033	95	190
2034	136	250
2035	193	310
2036	263	390
2037	336	470
2038	409	550
2039	476	630
2040	535	690
2041	585	750
2042	628	810

2043	663	850
2044	688	860
2045	707	870
2046	718	875
2047	725	880
2048	729	885
2049	731	890
2050	733	895

## Appendix 7 - Broads moorings ECP analysis &amp; Proposed locations

<b>Table A7.1: Proposed locations for 22kW and 7kW chargers in the demonstration network</b>					
Serial Number	Name	River	Co-ordinates		Existing ground infrastructure
			Easting	Northing	
1	Norfolk Broads Direct boatyard	Bure	630304	318024	3 Phase 100 Amps
2	Berney Arms	Yare	646790.5	305197.4	None – but adjacent to Internal Drainage Board pump with 100kW power supply
3	Great Yarmouth Yacht Station	Bure	652052.9	308677.6	3 Phase 100 Amps
4	Norwich Yacht Station	Yare (Wensum)	623839.7	308508.9	3 Phase 100 Amps
5	Beccles Yacht Station	Waveney	642185.1	291217.9	3 Phase 100 Amps.
6	Reedham Yacht Station	Yare	642131	301805.1	1 Phase 60 Amps
7	Ranworth Staithe	Bure	652052.9	308677.6	1 Phase 100 Amps x2 - serving separate “spurs” of the mooring
8	Potter Heigham	Thurne	641941.7	318384.1	1 Phase 100 Amps
9	Acle Bridge	Bure	641361.6	311731.8	3 Phase 100 Amps
10	Stalham/Sutton	Ant	638045.7	323710.2	Depending on 3rd party agreements, BA site has 1 Phase 100 Amps
11	St Benet’s Abbey	Ant/Bure Junction	637592.5	315995.6	None

## Specification for the Broads boat charging network

In order to have a fully electric hire craft on the Broads, there needs to be a network of charging points that can support cruises typically of a week long duration. This is the “Minimum Viable

Product” for the charging network. Due to the challenges associated with developing shoreside infrastructure and the phased conversion of fleets from reliance upon ICE propulsion to electric and other net zero systems, we foresee a phased transition.

The minimum criteria are that:

- A boat can reliably access the entire river network that is open to hire cruisers (this excludes the Waveney upstream of Geldeston lock, and the Wensum upstream of Bishopsgate Bridge.)
  - In determining the access to the network, charging points need to consider that Potter Heigham bridge, Beccles Bridge, Wroxham Bridge and Wayford Bridge are barriers to some boats in the hire fleet due to their low clearance. This includes the study boat. Therefore a charger placed on any mooring upstream of these bridges would not be useful to these boats.
- On the basis of surveys carried out with visitors to the broads, there must be no more than 5 hours between recharging points in the southern broads. Shorter distances are required in the Northern Broads where the boat will remain if it takes a more leisurely cruise or the holiday includes prolonged visits to towns and tourist sites, so we will aim for 2 hours between charging points.
- The charging points need to guarantee safe passage of the tidal reaches, and allow for a “top-up” on the approach to Breydon water, either via Great Yarmouth Yacht Station when heading West, or on the Waveney/Yare at the top of Breydon water when heading East.
- The electric boat should have access to the most attractive sites in the Broads whilst it is recharging. A boat that can only recharge away from pubs, tourist attractions, and other venues will not be attractive to potential hirers.

### Methodology selecting locations for charging points

In selecting locations for a minimum network of charging points, we have considered:

1. Which are the most popular moorings?
2. Do these moorings have access to other facilities that can be used whilst the boat is charging?
3. How far is the mooring from other charging points – does it fill a gap in the network?
4. How many spaces are available at the mooring – is it likely that an electric boat could find itself unable to moor at a needed electric charging point (ECP)?
5. Do the existing groundworks support installing boat charging points, and is there power available for the mooring in nearby substations for longer term development of the site?
6. What are the costs associated with adding the charging point to that location?

The Broads Authority holds the following data on each of the moorings on the Broads, which has been used for this assessment.

*For BA managed moorings*

- Length of the physical mooring
- Existing number of charging points
  - The type of grid connection supporting the charging points
  - Annual kWh of use from the charging points
- If the mooring point has a water tap
- Ordnance Survey (OS) Coordinates

*For Third party managed moorings*

- Length of the physical mooring
- OS Coordinates

In addition, during this assessment we have gathered the following additional information,

- Adjacent facilities (pubs/restaurants/shops/tourism attractions)
- Usage data – based on a physical survey for River Bure Moorings, and 2017 aerial data for the other moorings. This has been used to assess the popularity of a given mooring.

Hydrogen East holds data on the locations of substations around Norfolk and the spare capacity for the 33kv substations. They have worked with UK Power Networks to estimate the available capacity for each of the 11kv substations.

UK Power Networks were contracted to carry out a survey of the specific locations, giving a “RAG Rating” to indicate the ability to support additional charging, and an approximate cost range for upgrading infrastructure at each point.

The assessment of key points to electrify has been done using the common river stretches used by the Broads Authority – the Waveney, Yare, Lower Bure, Upper Bure and Thurne. For simplicity, the Ant and the Chet have been treated as part of the attached river (River Bure and Yare respectively), see Table A7:2 below.

<b>Table A7:2: Lengths of river sections in the Broads.</b>		
<b>River</b>	<b>Navigable length</b>	<b>Time to navigate at speed limit</b>
Upper Bure & Ant	35km	5 hours 15 minutes
Thurne	26km*	3 hours 45 minutes
Lower Bure	24km	2 hours 35 minutes
Yare & Chet	43 km	4 hours 50 minutes

Waveney	42km**	4 hours 25 minutes
---------	--------	--------------------

\*For the Thurne, this includes an amount of doubling back, as the river branches into multiple long channels.

\*\*For this table, both the Waveney and the Yare distances include Breydon Water. Breydon Water is usually classed as being a part of the river Yare – however, for reviewing how far a boat will travel, a boat travelling from the Northern Broads to Beccles will traverse Breydon Water.

The division into rivers is for ease of assessment; however, placement of desired charging points has been considered at a network level.

#### *Assumptions and considerations in the assessment*

The assessment has built upon the data gathering work carried out during the feasibility study, which included building a spreadsheet of all publicly accessible moorings on the Broads, their location, their size, their facilities, and their popularity.

Given the need to avoid range anxiety, boats departing on the penultimate day of their holiday from the furthest points of the Broads, a first consideration was the placement of chargers at the extremes of the Waveney and the Yare.

From a safety perspective, it was also considered important to ensure that boats crossing Breydon Water, the most tidal reach of the Broads, are able to access a charger – even if this would only be a short top-up rather than an overnight stay.

It is also presumed that the largest boatyards are likely to be early adopters of electric fleets, and would therefore have charging infrastructure. As hire boat yards on the Broads already have agreements to allow hirers from other yards to use their facilities, these provide obvious places to build out the network in the longer term.

In particular, larger boatyards needing to turn around a significant number of boats in the space of a few hours would be likely to install higher power chargers, which could be used in line with typical facility sharing agreements. However, for the purposes of the demonstration phase, these will not be available.

A final consideration if there are challenges installing chargers is the possibility to work with the Internal Drainage Board, which has a network of 100kW pumps around the Broads. These are to be replaced in the near future as part of a large-scale replacement programme to ensure the resilience of the Broads. As the pump's power needs are irregular, needing 100kW for short bursts but idle for the majority of the time (particularly in summer), a smart charging solution on the Broads could potentially dovetail with this network.

From those building blocks, the assessment has been carried out on each river section on the basis of the size of the moorings, the facilities present, the ease of adding a charging point, the popularity of the mooring, and the distance to other charging points.

Popularity is assessed on the basis of:

- In person survey (Upper Bure)
- Review of Aerial Photographs
- Power taken from existing electric charging pillars.

This is not a foolproof method, so this is not an overriding consideration.

### Assessment

For ease of deployment in the first phase, it is also worth considering the sites that are managed by the Broads Authority and already have 3 phase 100amp supply. This level of supply allows for 9 Charging plugs (32A at 240V provides for 7.6KW Charging) without needing more groundworks. In contrast, some sites with charging pillars have only 60A on a single phase.

The sites with 3 phase 100 Amp connections are:

- Great Yarmouth Yacht Station
- Norwich Yacht Station
- Neatishead 24 hour moorings
- Acle Bridge.

**Figure A7.1: Broads Authority managed locations with 3 phase power supply.**

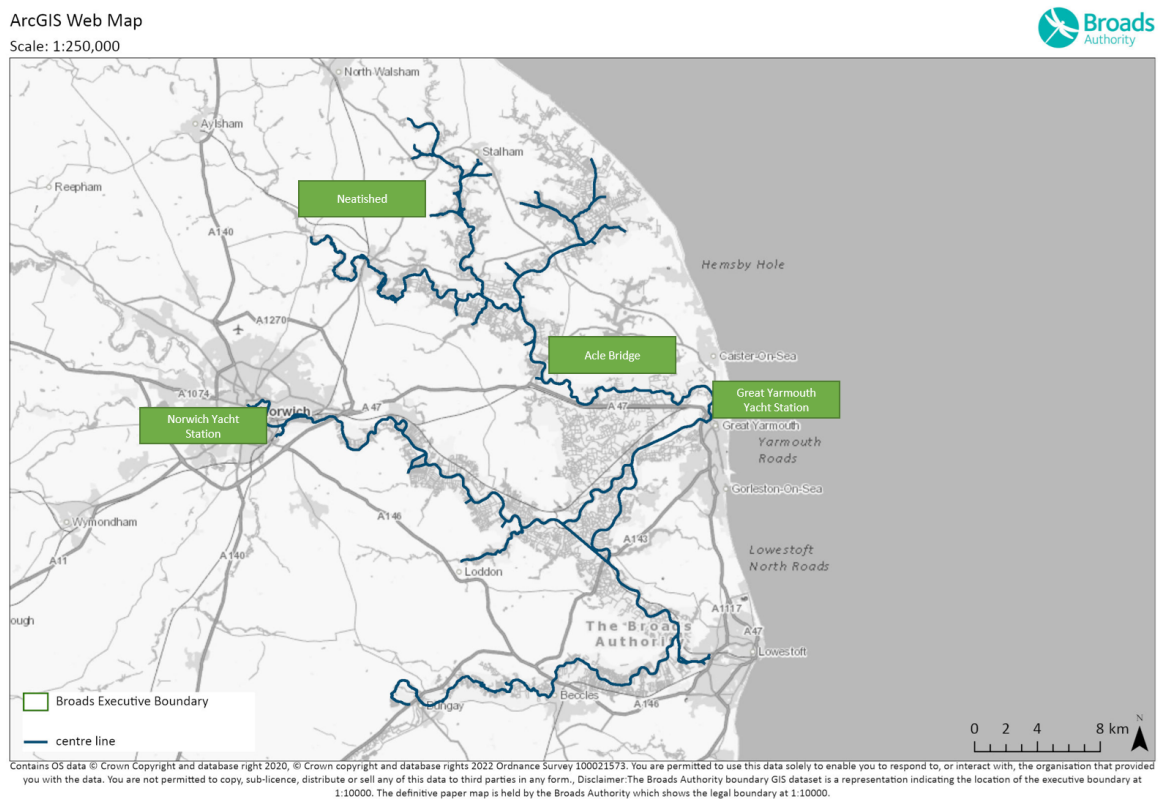

### Safety considerations – Breydon and lower reaches of the Yare and Waveney.

It is likely that safety considerations would require a charging, or at least a “top up” station at the top of Breydon Water to ensure vessels can safely cross the most tidal reaches of the Broads – as it would potentially be dangerous to navigate with insufficient power.

At the Eastern end of Breydon Water is Great Yarmouth Yacht Station, which would be the obvious location for a fast charging point, and already has a good power supply available.

The three closest mooring points to Breydon at the western end are Berney Arms, Polkey’s Mill, Burgh Castle. In terms of location (at the junction of the rivers) and mooring space, Berney Arms is the most desirable point to install a fast charger. However Burgh Castle has an existing power connection (albeit only single phase 100 Amps), and should be considered if cost is an issue. Polkey’s Mill could be used as a last resort.

(NB: The figures given for popularity are a count of boats at the mooring as viewed from the 2017 aerial footage.)

### Power Supply

Great Yarmouth Yacht Station is supplied by the Lawn Avenue Hostel substation which is rated at 200 kVA, which would support the anticipated number of MEVs in the next 10 years. It has an existing 3 phase supply so the only costs would be installing the new charging pillars.

The moorings at Berney Arms have no existing electrical infrastructure, so would need a new 3 phase power supply. This could be supplied from nearby infrastructure for a cost of around £10-20 thousand.

Whilst Burgh Castle has an existing single phase supply, upgrading this for the 3 phase supply needed for development as a charging site would cost over £100 thousand, so is not recommended for development.

Polkey’s mill likewise lacks existing connections, but could be fitted with a 3 phase supply for £10-15K.

<b>Name</b>	<b>Owner or Manager</b>	<b>Number of Spaces</b>	<b>Popularity</b>	<b>Power supply availability</b>	<b>Facilities</b>
Berney Arms	BA	35	9	None – but adjacent to Internal Drainage Board pump with 100 kW power supply	None at present – possibility that the pub may reopen in some form.
Polkey’s Mill	BA	6	2	None – But adjacent to IDB Pump	None
Burgh Castle	BA	14	3	Single Phase 100 Amps	Burgh Castle as a tourism destination

Figure A7.2: Potential Charging sites around Breydon water.

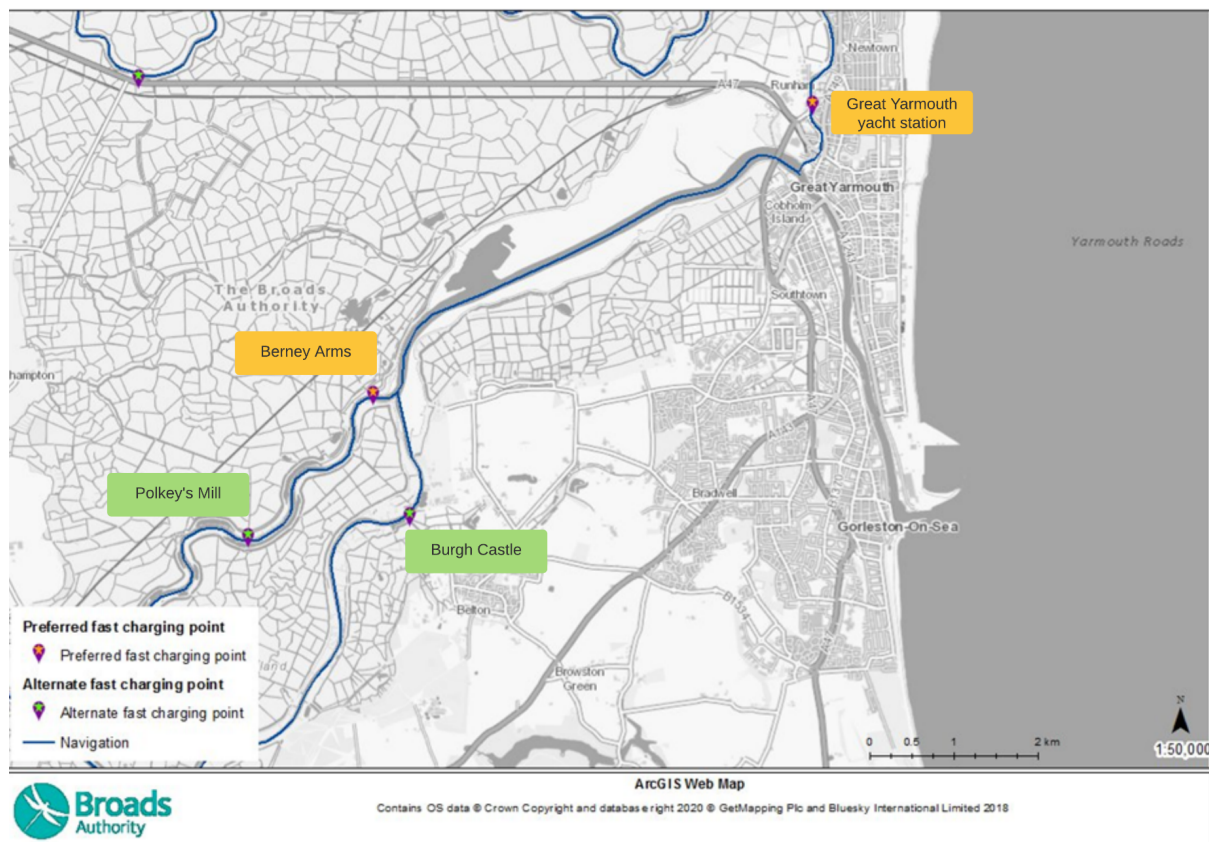

In Figure A7.2, marked with a Gold Star are Great Yarmouth Yacht Station (East) and Berney Arms (West). The other two sites are Polkey's Mill (West) and Burgh Castle (East).

### River Yare, Chet & Wensum

The River Yare flows into the North Sea at Yarmouth, and is navigable until it joins the Wensum just below Norwich at Whitlingham Country Park. The main navigation follows the Wensum up to New Mills yard in Norwich. Most hireboats are only insured to travel up to Bishopsgate Bridge, just upstream of Norwich Yacht station, located near Norwich Railway Station. The bridge is 1.5 miles below New Mills yard.

The river passes the towns of Reedham, Cantley and Brundall, with navigation possible to Rockland St Mary along a dyke, and to Loddon along the River Chet.

There are two existing Broads Authority Yacht Stations on this reach, at Norwich and Reedham. Norwich is the furthest navigable point from the large Hire Yards at Potter Heigham, Stalham and Wroxham – therefore a boat departing Norwich on the penultimate morning of a holiday would need to have a range of at least 80km.

On this reach, there are existing electric hook-up points at (from left to right) Norwich (chequered flag), Bramerton, Rockland St Mary, Loddon, Reedham (Chequered Flag).

There are hire vessel yards at Loddon and Brundall.

**Figure A7.3: Hook-up points on the river Yare.**

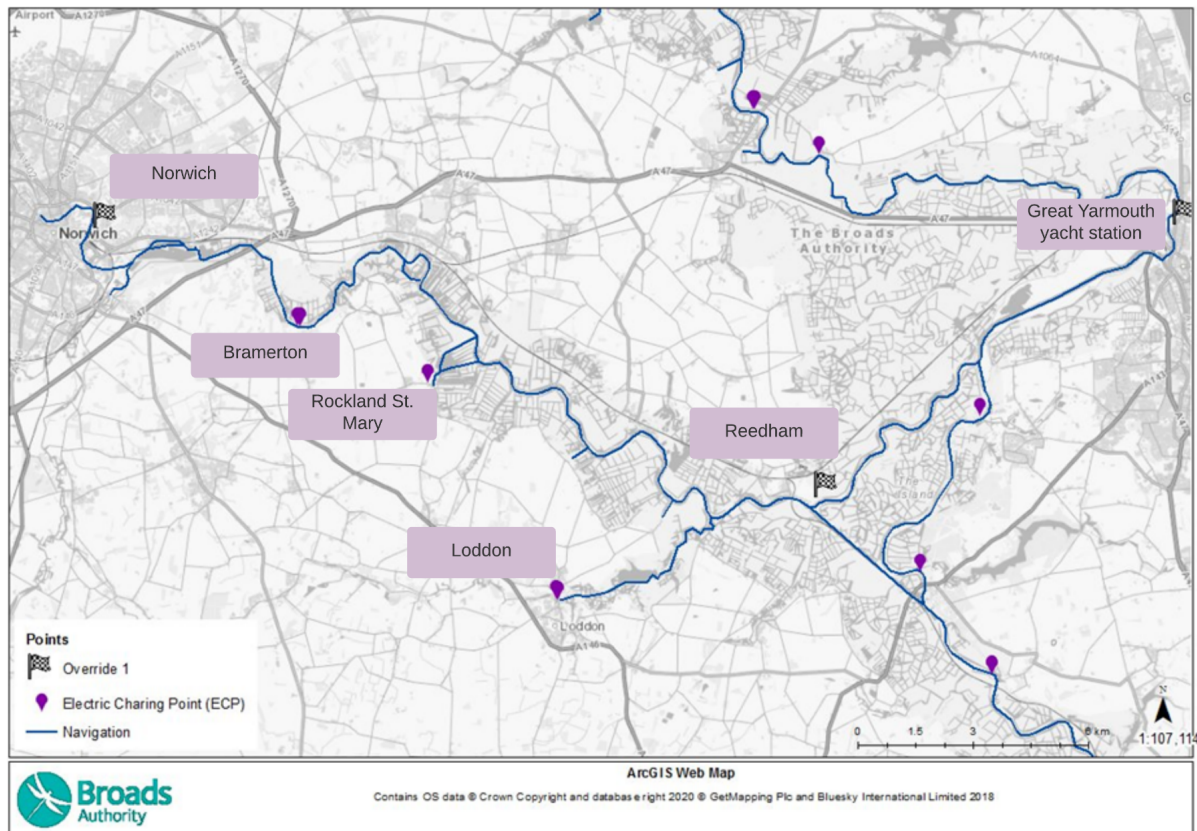

Electric hook-up points (purple pins) and Yacht Stations (Chequered flags) are shown above.

- Based on the 2017 aerial images, Norwich is the most popular mooring, with Bramerton a close second.
- Moorings at Norwich, Bramerton, Rockland St Mary, Cantley, Loddon and Reedham have access to pubs.
- Reedham, Norwich and Loddon have access to shops.
- Loddon Staithe, Bramerton and Reedham provide the most electricity from their hook up points.
- The site notes for Reedham note that the current infrastructure at the location cannot support more hook-up points, so an upgrade would be needed to move to a charger.
- Norwich Yacht Station has a 100Amp 3 phase connection, but as the Broads Authority is a tenant at this site, changes would need to be agreed with the land owner, Norwich City Council.

### Proposed Charger Locations

Charging points would need to be fitted at Norwich as the end of the navigation. If we are seeking to have only 4 hour gaps between chargers, the obvious location in terms of size of mooring and facilities is Reedham. Alternative sites if these are not viable would be at Loddon and Bramerton. On the map below, fast chargers are indicated with a yellow star, alternative options are marked with a green star. Loddon has a hire yard with 9 cruisers, which could be a location for a charging point.

Norwich and Reedham are 28km apart, or approximately 200 minutes of cruising. A proposed site at Berney Arms would be an additional 7km, or 45 minutes cruising. Therefore, if one is installed at Berney Arms, it could be viable not to have a charger at Reedham, though that is not a preferred option.

**Figure A7.4: Proposed charger locations between Norwich and Reedham.**

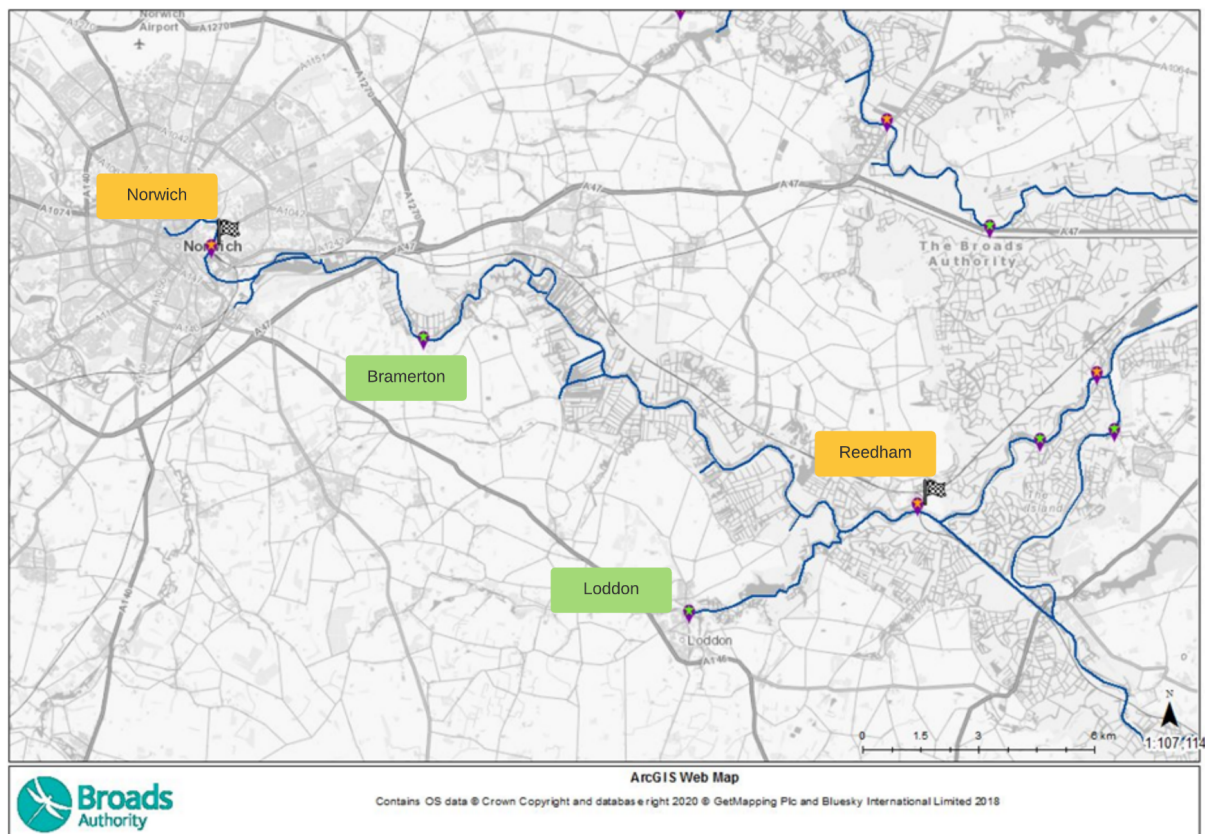

The pins with yellow stars show preferred charging points. Those with green stars show alternate locations (Bramerton (left) Loddon (Centre) alternative sites for the Breydon charger (right)). Yacht stations are marked with chequered flags

### Power supply

Reedham Yacht Station is supplied via the Riverside 200 kVA substation, which would support the anticipated number of MEVs in the next 10 years. However the ground infrastructure would need upgrading to a 3 phase supply, at a cost of £5-10 thousand.

Norwich Yacht Station is supplied via the Prince of Wales Road Substation, which is rated at 2 x 1000 kVA. The existing 3 phase supply would be adequate for the project, however in the long run additional cabling would be needed for the site. The main challenge for this would be crossing the river, but this could presumably be done via the foundry bridge.

**Table A7.4: Data on moorings on the Yare, Chet and Wensum**

Name	Owner or Manager	Mooring spaces	Popularity	Power supply	Facilities
Reedham Yacht Station	Broads Authority	30	14	Single phase 60 Amps	Yacht Station, pubs, shop
Loddon Staithe	Broads Authority	10	1*	Single phase 100 Amps	Pub, shop
Bramerton	Broads Authority	22	15	Single Phase 100 Amps	Pub
Norwich Yacht Station	Broads Authority	37	16	Three phase 100 Amps	Pub, shop, yacht station, tourist attractions

\*\*Whilst the groundworks are still in place at Whitlingham, the current managers of the site have discontinued the provision of Electric Pillars.

### River Waveney

The most upstream navigable point of the River Waveney for a cruiser is Geldeston Lock. However, many cruisers will be unable to pass under Beccles Bridge, which is 5km downstream. It meets the River Yare at the top of Breydon water, 34 km downstream from Geldeston (approximately 4 hours cruise). It is also connected to the River Yare by the Haddiscoe Canal (commonly known as the "New Cut"), which runs from St Olaves to Reedham.

There are existing Broads Authority electric hook up points at Somerleyton, St Olaves, and Burgh Castle and some provided by the Town Council at Beccles Yacht Station, and at Waveney River Centre near the junction with Oulton Dyke.

Figure A7.5: River Waveney hook-up points.

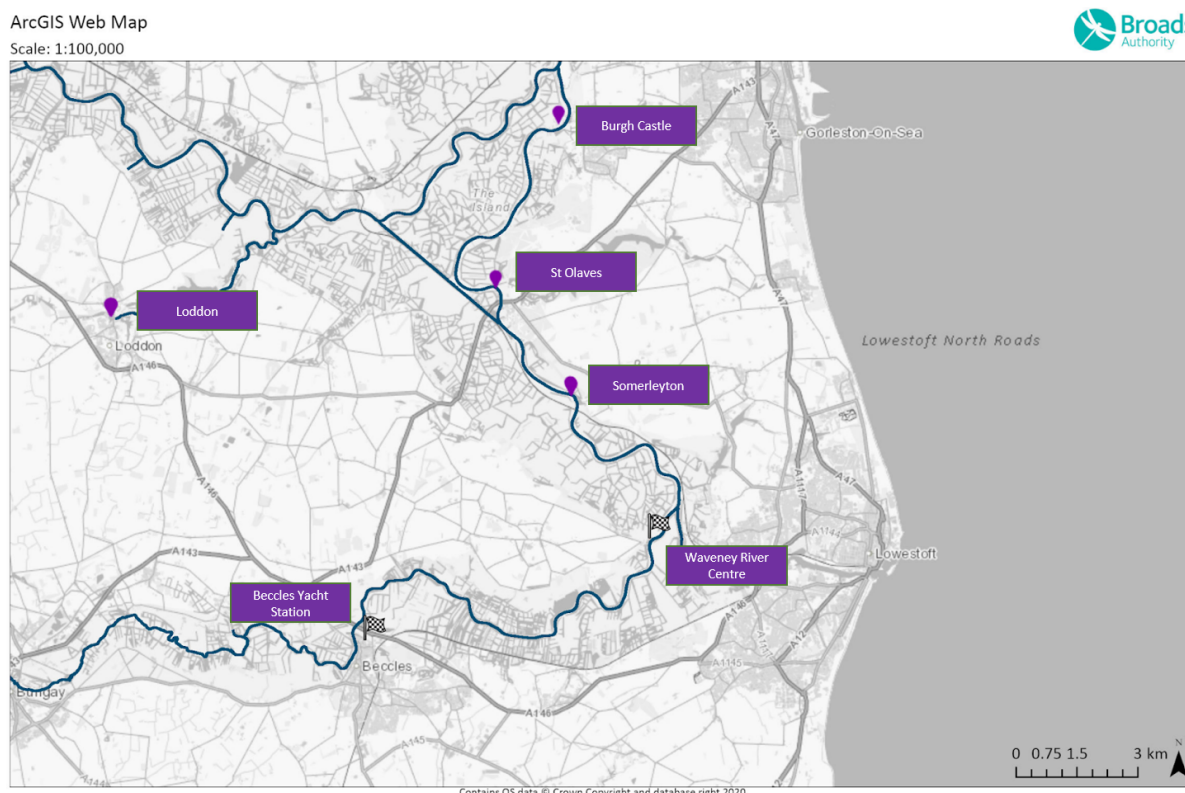

In Figure A7.5, existing locations of hook up points on the river Waveney. The Broads Authority locations are shown by purple pins, with Beccles and Waveney River Centre marked with flags.

### Considerations

- Moorings on the Waveney are limited in number, and generally have few facilities nearby. After Norwich, Geldeston and Beccles are the furthest points from the large hire yards in the Northern Broads. Therefore the same consideration as applied for the Yare – to avoid range anxiety boats, should be able to recharge at Beccles. This would need to be downstream of the Bridge Street Bridge to ensure it is accessible to all Broads cruisers. (NB: the A146 bridge is high enough for hire cruisers to pass under without issue).
- The location with the most facilities near the top of the navigation is the third party moorings at Beccles Yacht Station, managed by the Town Council.
- As an alternative, there is a smaller mooring managed by the Broads Authority (Beccles South Bank) a short walk upriver, if the Town Council did not wish to host a charging point.
- These are 29km/3 hours cruise from a potential charging site at Berney arms, or 24 km/2.5 hours cruising to a potential charging site at Reedham Yacht Station. Therefore, additional sites would not be needed as part of a minimum charging network.

Figure A7.6: River Waveney showing a potential charging location at Beccles.

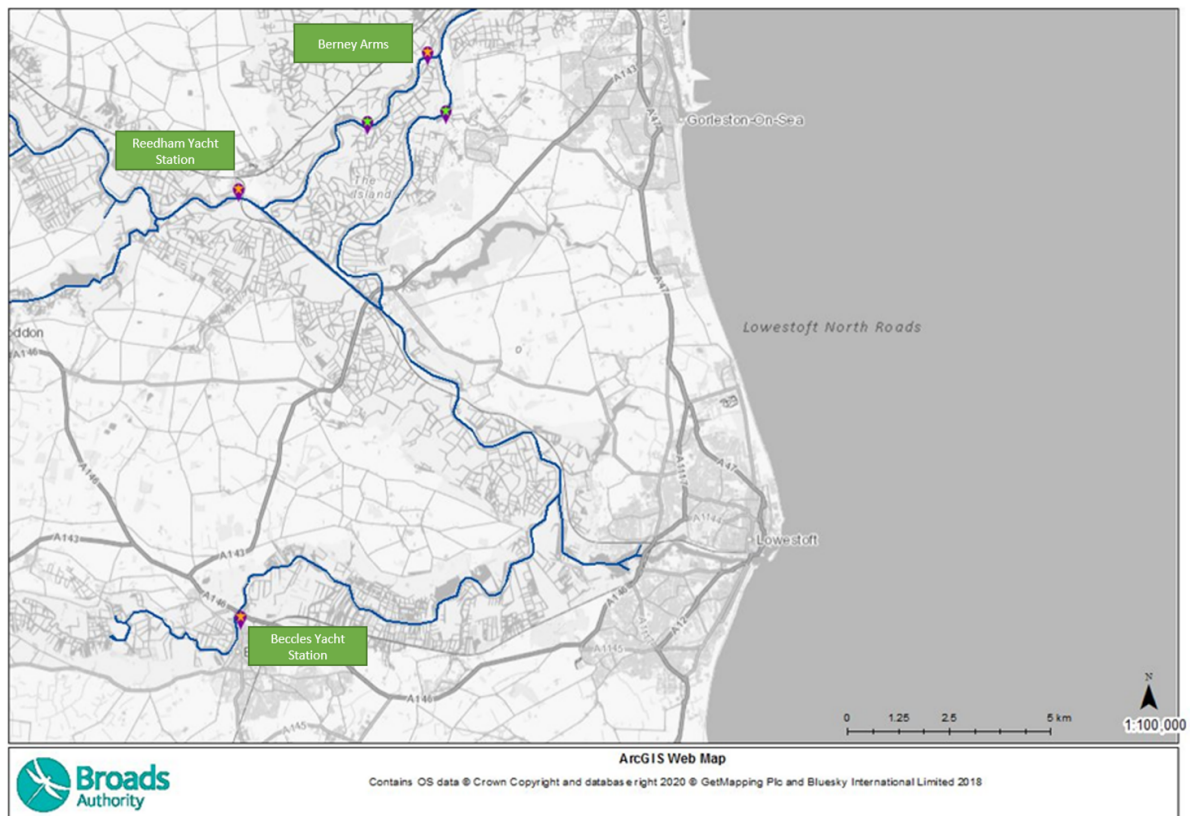

The charging points indicated to the North are discussed previously in the River Yare section and are shown in Figure A7.6, above.

### Power Supply & Land Ownership

Installing a 3 phase power supply at Beccles would cost in the region of £5-10 thousand, the existing substation can support the site. The Yacht Station is owned and managed by Beccles Town Council, who have previously indicated support for decarbonisation efforts, but would need to be consulted on the details of the proposal over the summer of 2022.

### Lower Bure

The Lower Bure is defined as the reach of the River Bure from Great Yarmouth to the junction with the River Thurne at Thurne Mouth, a distance of 22km, or 2 hours 20 minutes of cruising. It would be viable for a boat to cruise the Broads and not recharge during this stretch as it is within 4 hours of the hire boat yards of the Northern Broads, but given it lies on the more tidal reaches of the broads it would be desirable to have a charger to ensure customer confidence and flexibility, especially as Acle Bridge or the Stracey Arms are likely to be turning around points if they restrict their trip to the Northern Broads.

There are existing electric pillars at Acle and Stokesby, along with the Yacht station at Great Yarmouth.

**Figure A7.7: Existing electric points on the Lower Bure.**

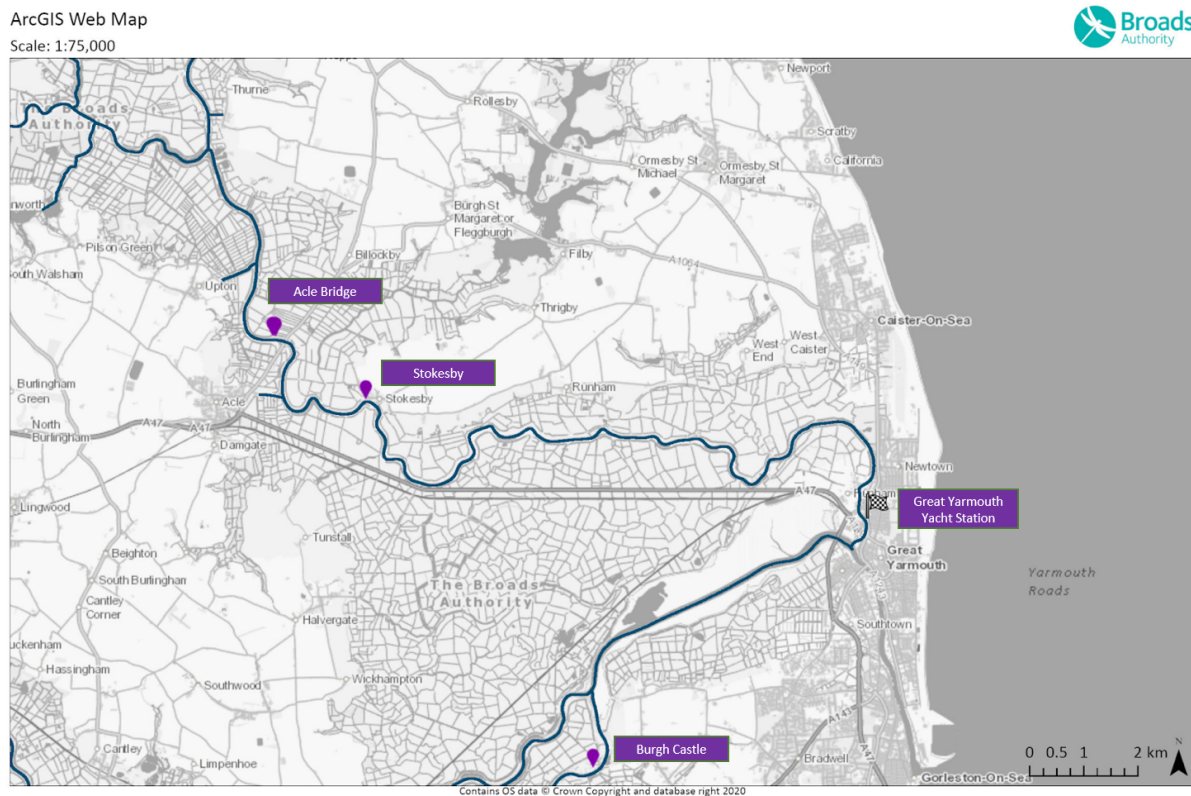

In Figure A7.7, Great Yarmouth yacht Station is marked with a chequered flag.

### Considerations

- There are two existing moorings with electric hook up points, at Acle Bridge and Stokesby. Apart from Acle Bridge and Stokesby, the largest mooring is at the Stracey Arms.
- Mooring at Stokesby is largely provided through an arrangement with a third party farmer, with only a short distance of Broads Authority Mooring.
- The most recently installed charge points at Acle Bridge have the existing 3 phase 100amp power supply. Stokesby has a single phase 100amp supply that would need upgrading if it were selected for a boat charging point.
- Power infrastructure at Stracey arms is unknown, and may be a viable alternative as there is ample mooring, and a pub. However, proximity to the A47 may make it less desirable to holiday makers than Acle Bridge, which has a pub and a footpath leading to Acle.
- There is a hire yard at Acle Bridge (BridgeCraft)

Figure A7.8: Lower Bure from Thurne Mouth (top left) to Great Yarmouth.

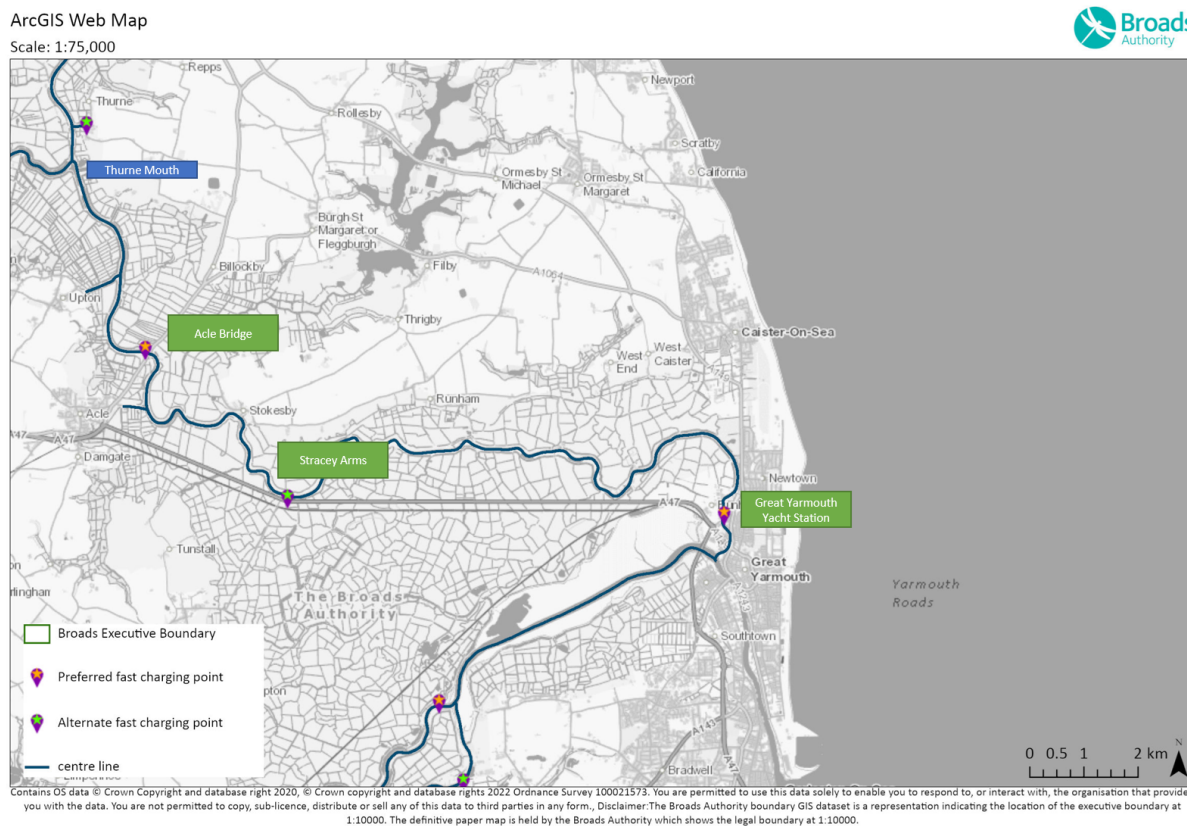

Figure A7.8 shows the proposed fast charging at Acle Bridge (left) and Great Yarmouth Yacht Station (right). The road running horizontally across the map is the A47, adjacent to the Acle Branch of the Wherry Lines railway. Thurne Mouth is the name given to the junction between the Rivers Bure & Thurne.

*Power Supply & Land Ownership*

Acle Bridge has an existing 3 phase 100 amp connection, so is the cheapest place to install a charger for the demonstration project. Installing a power supply at the Stracey arms would be estimated to cost £30 thousand. The 24 hour mooring is owned by the Broads Authority.

Name	Owner or Manager	Mooring spaces	Popularity	Power supply	Facilities
Great Yarmouth Yacht Station	Broads Authority	53	31	Three Phase - 100 Amps	Yacht Station, pubs, shop
Stracey Arms	Third Party - Public House	35	4		Pub

Acle Bridge	BA	20	10	Three Phase 100 Amps	Pub, Shop
-------------	----	----	----	-------------------------	-----------

### River Thurne

The river Thurne connects Hickling Broad and Horsey Mere to the Bure. There are substantial branches of dykes, leading to West Somerton, and to Waxham via Horsey Mere and Waxham Cut. The longest navigable distance in this section is 13km from Waxham to Thurne Mouth.

Most hire cruisers (including the study hire vessel) cannot pass Potter Heigham Bridge, therefore charging infrastructure upstream of the Bridge will be unusable to these boats.

There are currently no Electric Points upstream of Potter Heigham Bridge, there are points downstream of the Bridge. The connection at the Broads Authority mooring is only 100Amps single phase, and additional groundworks would be needed to add a boat charger.

A full exploration of the upper Thurne from Potter Heigham Bridge would cover 33km, or approximately 5 hours of cruising. This route starts at Potter Heigham, visits West Somerton, Horsey Wind Pump (National Trust Property), the top of Waxham Cut, crosses Hickling Broad, and then returns to Potter Heigham.

**Figure A7.9: Map of navigable routes upstream of Potter Heigham Bridge.**

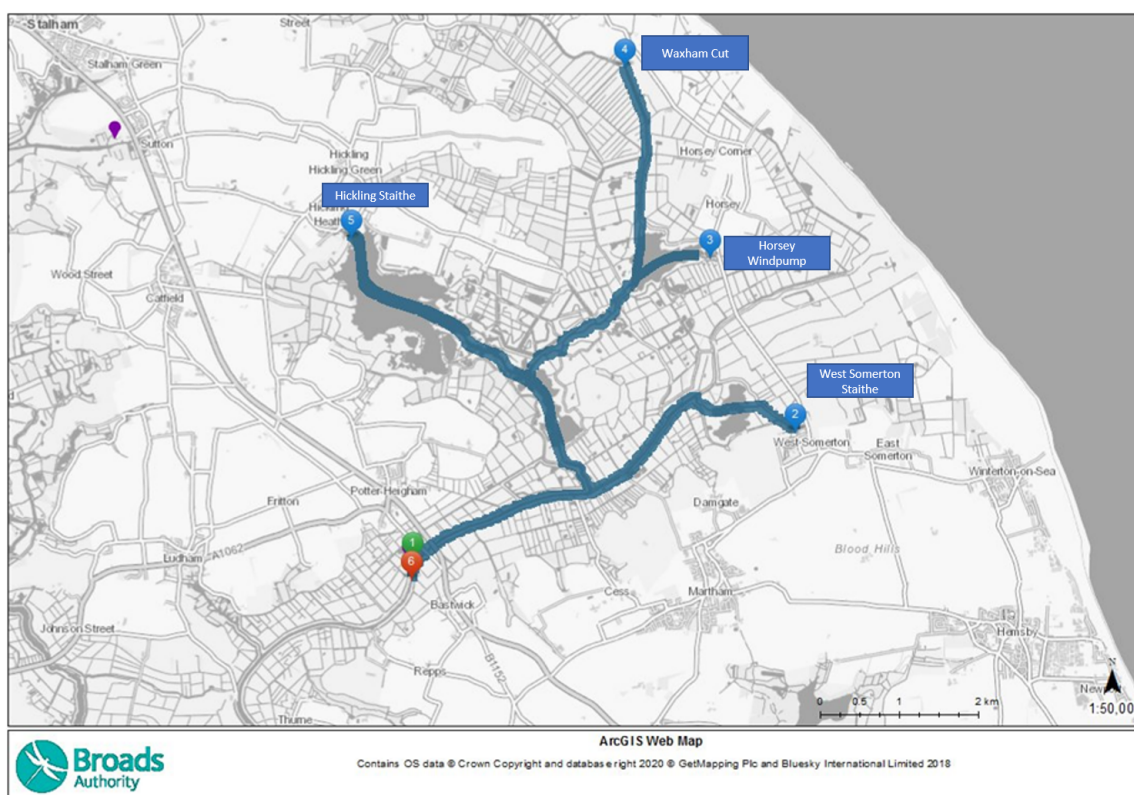

On this basis, given that Potter Heigham has a large number of facilities compared to the other moorings on the Thurne, it seems a natural spot for a charger. In terms of infrastructure, this could

either be placed on the BA mooring downstream of the bridge, or Herbert Woods (Hireboat Company) whose boatyard is just below the bridge could have a charger on their site.

Alternative locations with facilities on the Thurne are at Thurne Dyke, and at Womack Water (Ludham Staithe).

**Figure A7.10: Upper Thurne from Thurne mouth junction.**

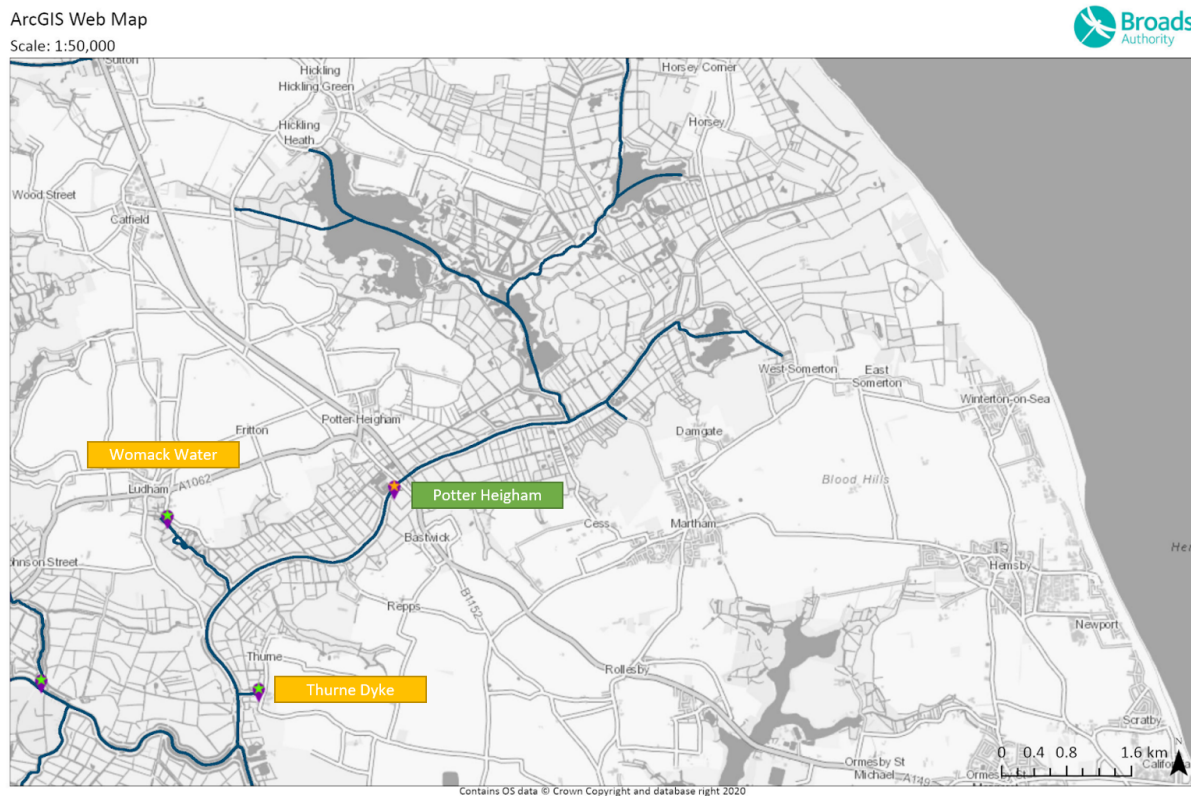

Figure A7.10 shows the Bure to the spurs leading to Hickling Broad, Horsey Mere and Martham Broad.

### *Power Supply & Land Ownership*

If an agreement is made with Herbert Woods to site a charger on their site, the electronics could probably be included within their 300KVA substation. Otherwise, installation on the Broads Authority site would require an upgrade to 3 phase 100amp supply at a probable cost of £5-10 thousand, as the existing single phase infrastructure is at capacity. The BA 24 hour moorings at Potter Heigham are leased from the Environment Agency, from whom consent would have to be obtained in summer 2022.

If a charger were to be installed at Thurne Dyke, a 3 phase supply could be installed for £5-10 thousand. This would involve negotiation with a third party landowner however, which would be

easier for future roll out after proof of concept. Ludham Staithe would be more expensive, at approximately £10-20 thousand, and would likewise require agreement from a 3rd party landowner.

<b>Name</b>	<b>Owner or Manager</b>	<b>Moorings spaces</b>	<b>Popularity</b>	<b>Power supply</b>	<b>Facilities</b>
Potter Heigham	Broads Authority	17	11	Single Phase 100 Amps	Pub, shop
Thurne Dyke	Third party	40	16		Pub
Ludham Staithe	Third party	18	13		Pub, Shop

### River Ant and Upper Bure

These rivers are at the heart of the Broads Hireboat industry, with several major boatyards present, including the demonstration yard Norfolk Broads Direct. There are also a large number of attractions (Museum of the Broads, How Hill Estate, various nature reserves), and the settlement of Hoveton & Wroxham which depends heavily on the Broads Tourism industry. These are officially two parishes, but they are essentially one settlement straddling the River Bure.

Figure A7.10: Map of boatyards in the Ant and Bure.

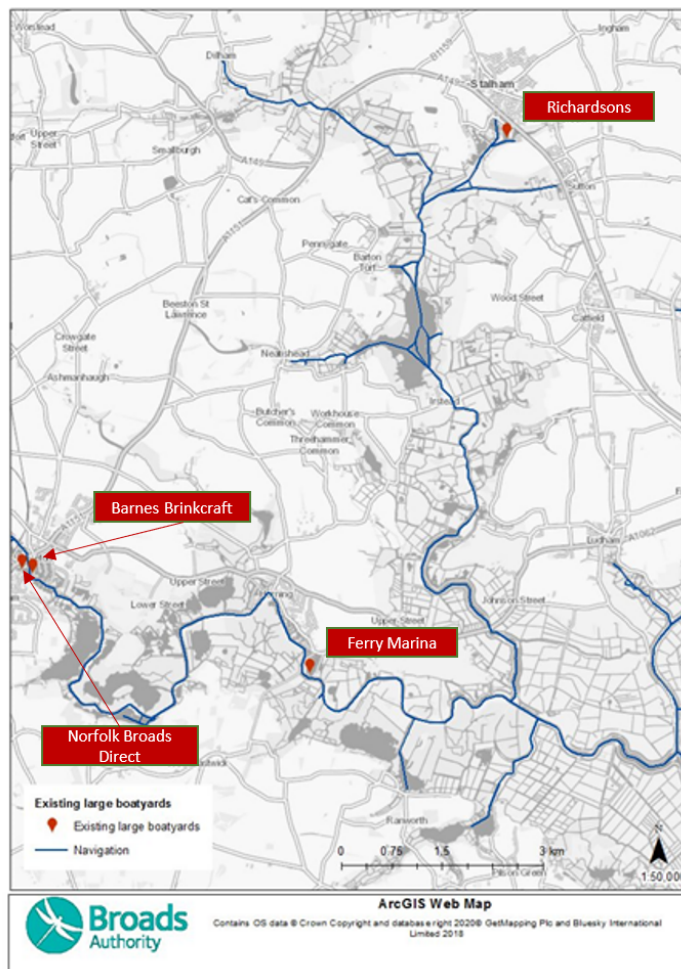

There is a low bridge at Wroxham, that prevents navigation for some of the hire cruisers on the Broads (including the case study boat). The river upstream of the bridge is navigable to Horstead Mill at Coltishall, a distance of 9.2km. This is short enough that it can be supported by a charger downstream of the Bridge in Wroxham. (A total of 180 minutes of cruising for a return trip to Coltishall.

Given the size of the boatyards at Wroxham and Stalham, it can be assumed that there would be charging facilities provided there. This influences the long term design of the network, but these locations will not be available for the demonstrator project, so other locations will need to be considered.

A cruise from Wroxham to Stalham via Dilham (on the Western Branch of the Ant) would consist of 5 hours of cruising. A return to Ranworth would take an additional 2 hours, for 7 hours of cruising.

It should be noted that this would be a less energy intensive cruise than the same time on much of the Southern Broads, as the speed limits are generally lower in this area of the Broads than compared to much of the Lower Bure, Waveney and Yare. This would need confirming through the

data logging of energy demand against GPS vessel location in the demonstration project, as it may be offset by the narrowness of the river on some reaches of the Ant.

**Figure A7.11: Speed Limits on the Northern Broads.**

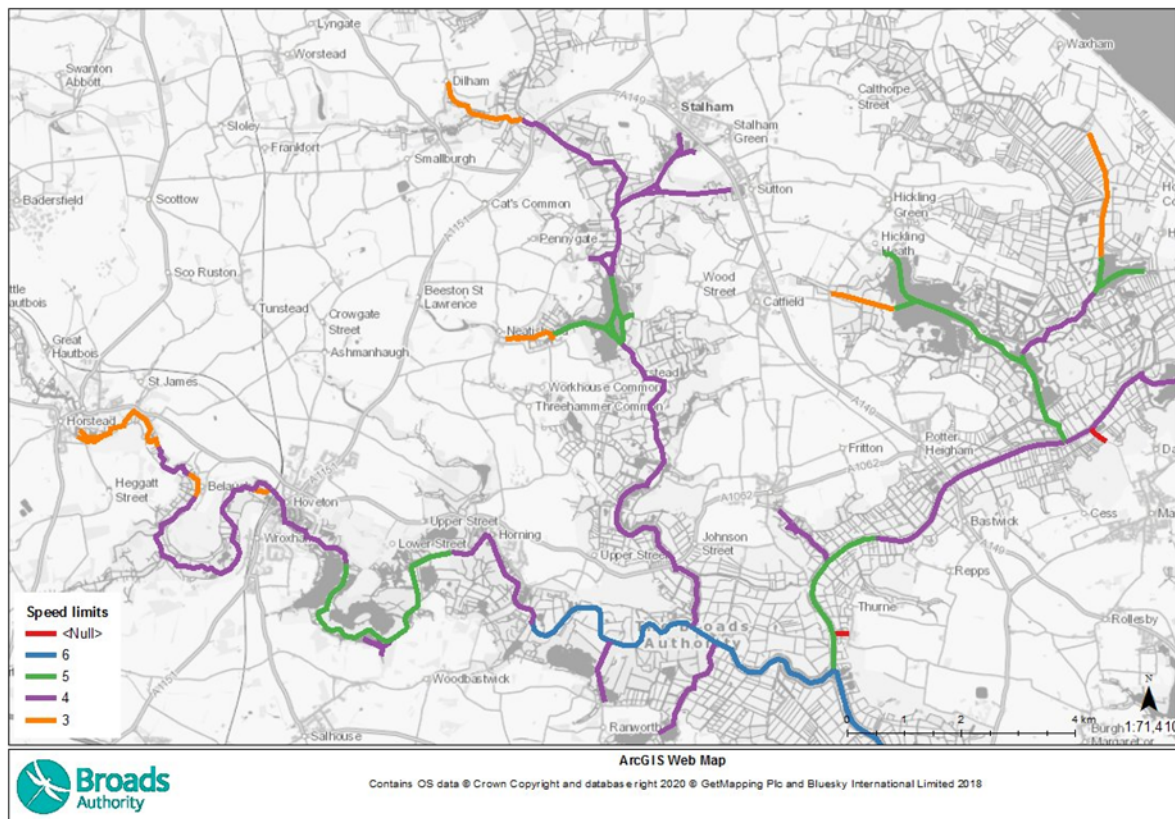

In Figure A7.11, speed limits are given as mph. The maximum speed limit on the broads is 6mph.

In addition to Stalham and Wroxham, given that boats are likely to spend a significant amount of times in this area, it would be advisable to have another charging point in the region of the junction between the Ant and Bure – this is a central point approximately 2 hours cruise from Stalham, Wroxham, Potter Heigham and Acle Bridge, which have already been considered in this report as potential locations.

The two closest mooring areas to the junction are Ranworth Staithe (on Malthouse Broad) and the St Benet’s Abbey Moorings on the River Bure, immediately adjacent to the mouth of the Ant.

Ranworth is an extremely popular mooring due to its proximity to the start/end point of many holidays, good facilities in the village, and the nearby Norfolk Wildlife Trust Nature reserve. It probably experiences the highest mooring pressure of any point on the network. This issue is highlighted in the discussion of the Broads mooring Survey in Appendix 1.

St Benet’s Abbey Moorings are potentially less in demand, but also suffer from overcrowding as it lacks facilities apart from a mid-distance walk to the pub at Ludham Bridge. A third option is for a charging point on Ranworth Island, however this has no land access to any facilities. However,

offering a variety of mooring types in this area may be attractive, giving a choice between village and rural moorings.

**Figure A7.12: Potential Charger Locations in the vicinity of the Bure/Ant Junction.**

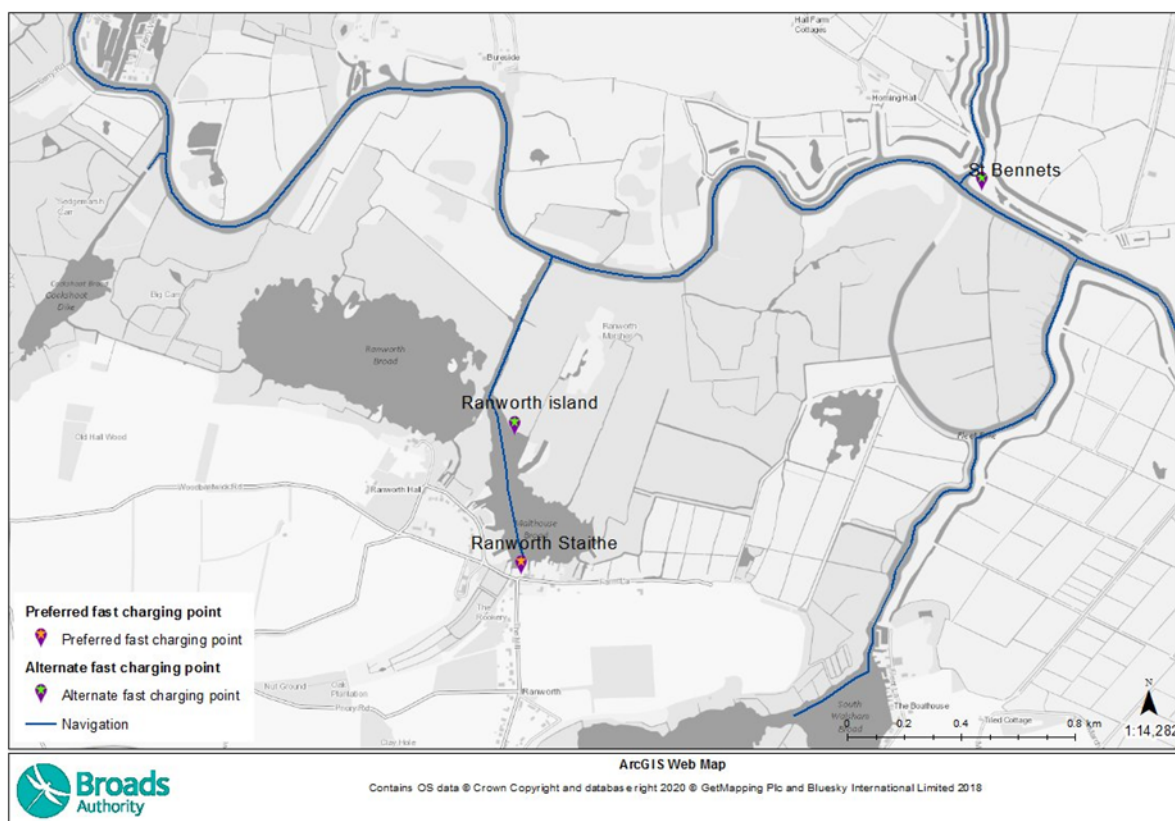

### *Power supply & Land Ownership*

Ranworth Island has been ruled out as a viable option by the UKPN survey, due to the lack of any power supply to the North of Malthouse Broad. (NB: Ranworth Staithe is on Malthouse Broad, Ranworth Broad is to the west, and is closed to boat traffic as a Nature Reserve).

Ranworth Staithe would require a new transformer, and is estimated to cost £10-15 thousand. The staithe is owned by the Broads Authority.

St Benet's Abbey is a long distance from nearby power connections, and these connections would need to be upgraded, costing in the region of £30 thousand. Installation of a charger at St Benet's would require permission from the Lessor, and there would need to be consideration of the angling competitions that occasionally take place at this location.

<b>Name</b>	<b>Owner or Manager</b>	<b>Mooring spaces</b>	<b>Popularity</b>	<b>Power supply</b>	<b>Facilities</b>
Ranworth Staithe	Broads Authority	22	22	100 amp single phase x 2	Pub, Tourist attraction
Ranworth Island	Third Party	25	4	None	
St Benets Abbey	Broads Authority	30	9	None	Tourist attraction

### Upper Ant

During the trial period, when there will not necessarily be charging infrastructure at all boatyards, a further point on the upper reach of the Ant can be considered, as there will be a charger at Norfolk Broads Direct. Broads Authority moorings are at Stalham Staithe and Sutton Staithe. Stalham Staithe has access to a greater amount of facilities, and is adjacent to the Museum of the Broads Tourism attraction, however is a very small mooring. Although Sutton already has existing ECPs, the site has only a single phase 100 Amp connection and is at capacity. An alternative may be to work with Richardson's boatyard at Stalham to introduce a 7 kW charger on their site, if there is spare capacity on their existing 200 kVA substation, or seek to upgrade the connection to a 3 phase connection at Sutton Staithe for approximately £5-15 thousand.

Figure A7.13: Potential Charging locations on the upper Ant.

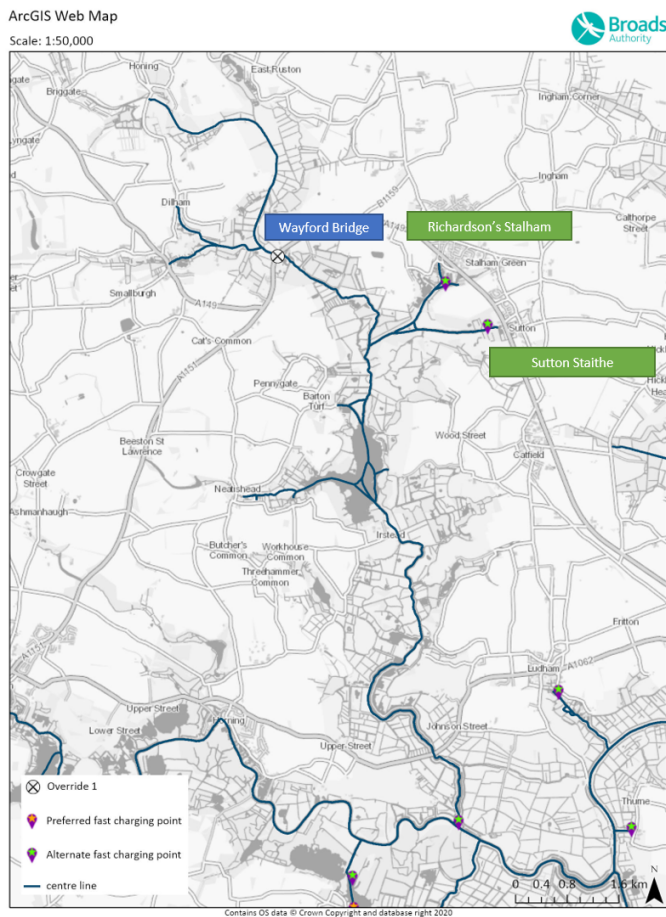

In Figure A7.13, note that the elongated navigation to the North of Wayford Bridge is inaccessible to all boats larger than a small dinghy or Kayak, so only a short part of usable navigation is cut off by Wayford Bridge.

### Mooring management issues

- Within the by-laws, the Broads Authority can only reserve spaces for sailing boats, which is designed to ensure that demasting areas are kept clear. The BA can set time limits, so fast charging locations could have time limits applied.
- Rangers would not be able to enforce moorings - they have the power to move on boats but would inevitably find overcrowded moorings unable to be managed.
- One solution is fast chargers on the less desirable moorings, but this then makes the boats less desirable.

## Full list of locations assessed in the Broads

NB: BA = Broads Authority TP=Third Party. Cells marked in Gray indicate a lack of data, or the data is irrelevant (for instance, mooring is only for use for demasting).

		OS Coordinates			Planning	Charging Information	Facilities					
UnitName	Responsible Party	easting	northing	River	Dark Sky Zone	Current number of Charging points	Water Point Count	Pub/eatery	Shop	Tourist Attraction	Yacht Station	Number of spaces
Commissioners Cut	BA	626671.8 843	308189.26 51	Yare	3	0	0	No	No	No	No	9
Berney Arms Reach	BA	646601.2 433	305128.02 05	Yare	2	0	0	No	No	No	No	35
Polkeys Mill Moorings	BA	644600.3 762	303532.48 51	Yare	2	0	0	No	No	No	No	6
Rockland Staithe	BA	632841.4 49	304606.18 81	Yare	2	2	0	Yes	No	No	No	10
Postwick Wharf	BA	630758.3 453	307592.51 98	Yare	2	0	0	No	No	No	No	4
Brundall Church Fen	BA	631990.9 666	308032.29 2	Yare	2	0	0	No	No	No	No	3
Hardley Cross	BA	640048.5 592	301221.47 38	Yare	2	0	0	No	No	No	No	11
Reedham Swing Bridge Downstream	BA	642458.0 826	301554.57 14	Yare	2	0	0					
Reedham Swing Bridge Upstream	BA	641948.2 213	301652.18 25	Yare	2	0	0					

		OS Coordinates			Planning	Charging Information	Facilities					
UnitName	Responsible Party	easting	northing	River	Dark Sky Zone	Current number of Charging points	Water Point Count	Pub/eatery	Shop	Tourist Attraction	Yacht Station	Number of spaces
Cantley	BA	638101.0451	303347.7857	Yare	2	0	0	Yes	No	No	No	20
Bramerton	BA	629537.244	306091.6898	Yare	3	3	0	Yes	No	No	No	22
Langley Upstream	BA	636551.3125	302725.2946	Yare	2	0	0	Treated as single unit with downstream, site				
Langley Downstream	BA	636593.6907	302756.115	Yare	2	0	0	No	No	No	No	11
Rockland Short Dyke	BA	633614.5602	305095.3125	Yare	2	0	0	No	No	No	No	20
Whittingham Country Park (Mooring)	TP	625141.8891	307946.8754	Yare	3	0	0	Yes	No	No	No	10
Norwich Yacht Station	BA	652052.9	308677.6	Yare	3	3		yes	Yes	Yes	Yes	37
Reedham Yacht Station	BA	623839.7	308508.9	Yare	2	2		Yes	Yes	Yes	Yes	30
Rushcutters, Thorpe	TP	626305.2646	308346.1518	Yare	3			Yes	YEs	No	No	3
Bramerton Woods End	TP	629101.069	306227.7502	Yare	3			Yes	No	No	No	13
Surlingham ferry	TP	630815.3914	307553.7805	Yare	2			Yes	No	No	No	19
Coldham Hall	TP	632491.441	307143.4773	Yare	2			Yes	No	No	No	6
Beauchamp Arms	TP	635003.0837	304453.1581	Yare	2			Yes	No	No	No	

		OS Coordinates			Planning	Charging Information	Facilities					
UnitName	Responsible Party	easting	northing	River	Dark Sky Zone	Current number of Charging points	Water Point Count	Pub/eatery	Shop	Tourist Attraction	Yacht Station	Number of spaces
Red Mill / House Reedham	TP	642201.342	301688.4888	Yare	2			Yes	Yes	Yes	No	6
Thorpe River Green Parish staithe	TP	626164.4763	308383.5908	Yare	3			Yes	Yes	No	No	20
Ribs of Beef	TP	623216.6787	308985.4253	Yare	0			Upstream of Bishopsgate Bridge so inaccessible to hire craft				
River Garden	TP	625684.6473	308391.4861	Yare	3			Yes	Yes	No	No	1
Rushcutters, Thorpe	TP	626305.2646	308346.1518	Yare	3			Yes	Yes	No	No	1
Surlingham ferry	TP	630815.3914	307553.7805	Yare	2			Yes	No	No	No	6
Brundall Parish Moorings	TP	631970.5414	308059.4343	Yare	2			No	No	No	No	6
Reedham Ferry	TP	640772.521	301528.4863	Yare	2			Yes	No	No	No	13
Burgh St Peter, Waveney River Centre	TP	649323.1423	293518.626	Waveney	2	Available	Available	Yes	Yes	Yes	No	
Oulton Broad Yacht Station	TP	651916.0886	292750.2596	Waveney	3	Available	Available	Yes	Yes	Yes	Yes	
Beccles Yacht Station	TP	642236.6826	291159.9586	Waveney	2	Available	Available	Yes	Yes	Yes	Yes	
Bell Inn	TP	645709.2125	299413.0555	Waveney	2			Yes	Yes	No	No	5

		OS Coordinates			Planning	Charging Information	Facilities					
UnitName	Responsible Party	easting	northing	River	Dark Sky Zone	Current number of Charging points	Water Point Count	Pub/eatery	Shop	Tourist Attraction	Yacht Station	Number of spaces
Burgh Castle	TP	647281.6086	303766.885	Waveney	2							
Geldeston Lock	BA	639056.5168	290819.3796	Waveney	1	0	0	Yes	No	No	No	7
Beccles South Bank	BA	642133.757	291415.7839	Waveney	2	0	0	Yes	Yes	Yes	No	6
Herringfleet	BA	646245.8441	298273.8087	Waveney	2	0	0	No	No	No	No	10
Dutch Tea Gardens Pontoon	BA	650149.8416	293039.7531	Waveney	2	0	0	No	No	No	No	6
Dutch Tea Gardens Oulton Dyke	BA	650156.728	293093.6136	Waveney	2	0	0	No	No	No	No	6
North Cove	BA	646623.4979	291123.3667	Waveney	2	0	0	No	No	No	No	4
Somerleyton Statithe	BA	647512.718	297088.378	Waveney	2	2	0	Yes	No	No	No	20
Beccles North Bank	BA	642091.7588	291412.9277	Waveney	2	0	0	Yes	Yes	Yes	No	2
Worlingham	BA	645136.4611	291492.9372	Waveney	2	0	0	No	No	No	No	5
Somerleyton Layby Moorings	BA	647470.1829	296566.3736	Waveney	2	0	0					
St Olaves	BA	645684.2872	299678.4214	Waveney	2	3	0	Yes	Yes	No	No	5

		OS Coordinates			Planning	Charging Information	Facilities					
UnitName	Responsible Party	easting	northing	River	Dark Sky Zone	Current number of Charging points	Water Point Count	Pub/eatery	Shop	Tourist Attraction	Yacht Station	Number of spaces
Peto's mooring	BA	650109.7 159	292907.69 25	Waveney	2	0	0	No	No	Yes	No	4
Burgh Castle	TP	647272.5 647	303774.52 86	Waveney	2	2	0	No	No	Yes	No	14
White Slea	BA	642974.2 94	320882.11 88	Thurne	1	0	0	No	No	No	No	2
Deep Go Dyke	BA	643004.0 16	320821.95 21	Thurne	1	0	0	No	No	No	No	7
Deep Dyke	BA	642535.8 537	321139.90 63	Thurne	1	0	0	No	No	No	No	19
Potter Heigham Bridge Green	BA	642031.7 143	318528.75 71	Thurne	2	0	0	Yes	Yes	No	No	10
Womack Island (mooring)	BA	639320.3 595	317724.94 06	Thurne	2	0	0	No	No	No	No	3
Potter Heigham Dinghy Park	BA	642130.5 203	318604.55 12	Thurne	2	0	0					
Potter Heigham Repps Bank	BA	641917.3 819	318355.48 9	Thurne	2	2	0	Yes	Yes	No	No	17
Potter Heigham De-masting	BA	641855.7 083	318324.65 79	Thurne	2	0	0					
Catfield Staithe	BA	640023.5 747	321828.09 85	Thurne	1	0	0	No	No	No	No	3
West Somerton	BA	646661.3 916	320077.68 16	Thurne	1	0	1	Yes	No	No	Yes	14

		OS Coordinates			Planning	Charging Information	Facilities					
UnitName	Responsible Party	easting	northing	River	Dark Sky Zone	Current number of Charging points	Water Point Count	Pub/eatery	Shop	Tourist Attraction	Yacht Station	Number of spaces
Womack Dyke	BA	639688.2 164	317437.82 76	Thurne	2	0	0	No	No	No	No	13
Potter Heigham Staithe	BA	641957.0 953	318488.16 84	Thurne	2	0	0	Yes	Yes	Yes	No	
Potter Heigham Martham Bank	BA	642169.6 482	318581.25 46	Thurne	2	0	0	Yes	Yes	No	No	14
Horsely Windpump - National Trust	TP	645720.6 611	322165.64 8	Thurne	1			Yes	No	Yes	No	18
The Bridge Inn PH	TP	641490.3 219	311632.37 61	Thurne	2			Yes	Yes	No	No	9
Ludham Staithe	TP	639119.2 1	318024.23 17	Thurne	2			Yes	Yes	No	No	18
Repps Mooring	TP	641326.2 004	317484.71 17	Thurne	2			No	No	Yes	No	2
Thurne Bank Mooring Company	TP	641710.5 298	317817.61 84	Thurne	2			No	No	No	No	10
Thurne Dyke	TP	640159.2 223	315877.88 67	Thurne	2			Yes	No	Yes	No	40
Haddiscoe Demasting (East)	BA	645409.0 699	299104.17 51	Haddiscoe Cut	2	0	0					
Haddiscoe Demasting (West)	BA	645341.6 184	299159.66 02	Haddiscoe Cut	2	0	0					
Loddon Staithe	BA	636208.3 75	298994.31 77	Chet	2	3	0	Yes	Yes	No	No	10

		OS Coordinates			Planning	Charging Information	Facilities					
UnitName	Responsible Party	easting	northing	River	Dark Sky Zone	Current number of Charging points	Water Point Count	Pub/eatery	Shop	Tourist Attraction	Yacht Station	Number of spaces
Pye's Mill	BA	636676.5811	299094.8117	Chet	2	0	0	No	No	No	No	20
Chedgrave	BA	637269.4205	299212.8025	Chet	2	0	0	No	No	No	No	4
Stokesby	BA	643038.2044	310558.1729	Bure	2	1	0	Yes	Yes	No	No	4
St Benet's Abbey	BA	637805.8169	315822.0228	Bure	2	0	0	No	No	Yes	No	60
Hoveton Viaduct	BA	630071.245	318488.2956	Bure	2	0	0	Yes	Yes	No	No	64
Hoveton St John	BA	630303.3482	318264.7606	Bure	3	2	0	Yes	Yes	No	Yes	20
Cockshoot Dyke	BA	634676.9637	316068.6954	Bure	2	0	0	No	No	No	No	11
Horning Parish Staithe	BA	633993.5696	317560.4494	Bure	2	2	0	Yes	Yes	No	No	12
Coltishall Common	BA	627840.6942	319710.3514	Bure	3	1	0	Yes	Yes	No	No	46
Belaugh Staithe	BA	628846.0273	318554.0283	Bure	2	0	0	No	No	No	No	2
South Walsham	BA	637230.7677	313984.6012	Bure	2	0	0	No	No	No	No	
Wroxham Island (downstream)	BA	631160.8	316557.0554	Bure	2	0	0	Considered with upstream moorings				

		OS Coordinates			Planning	Charging Information	Facilities					
UnitName	Responsible Party	easting	northing	River	Dark Sky Zone	Current number of Charging points	Water Point Count	Pub/eatery	Shop	Tourist Attraction	Yacht Station	Number of spaces
Wroxham Island (upstream)	BA	631375.5 893	316796.53 11	Bure	2	0	0	No	No	No	No	10
Boundary Farm	BA	640197.3 262	314789.63 96	Bure	2	0	0	No	No	No	No	4
Acle Bridge	BA	641154.5 575	311742.07 29	Bure	2	3	0	Yes	Yes	No	No	20
Scare Gap Emergency Mooring	BA	649814.4 042	309127.09 35	Bure	2	0	0	No	No	No	No	3
Ranworth Staithe	BA	635972.1 664	314628.37 68	Bure	2	4	1	Yes	Yes	Yes	No	22
Runham Pontoon	BA	648051.5 708	309881.84 8	Bure	2	0	0	No	No	No	No	2
Castle Staithe	BA	629568.2 706	317224.28 55	Bure	2	0	0	No	No	No	No	3
Great Yarmouth yacht Station	BA			Bure	3	1		Yes	Yes	Yes	Yes	53
Ferry Public House Stokesby	TP	643123.5 227	310487.03 64	Bure	2			Yes	Yes	No	No	12
Moorings provided by the local farmer	TP	643176.1 647	310416.32 58	Bure	2			Yes	yes	No	No	10
EA Mooring at South Walsham	TP	637274.8 101	314523.74 43	Bure	2			No	No	No	No	12
EA Mooring	TP	637559.5 913	314900.93 64	Bure	2			No	No	No	No	12

		OS Coordinates			Planning	Charging Information	Facilities					
UnitName	Responsible Party	easting	northing	River	Dark Sky Zone	Current number of Charging points	Water Point Count	Pub/eatery	Shop	Tourist Attraction	Yacht Station	Number of spaces
Ranworth Island	TP	635975.5072	315024.7696	Bure	2			No	No	No	No	25
The Swan, Horning	TP	633960.7837	317595.8092	Bure	2			Yes	Yes	No	No	4
Horning Ferry	TP	634413.7704	316493.5173	Bure	2			Yes	No	No	No	17
Salhouse Broad	TP	631927.8719	315645.1511	Bure	2			No	No	Yes	No	43
Rising Sun	TP	627681.9398	319775.8021	Bure	3			Yes	No	No	No	2
Hoveton Great Broad Nature Trail	TP	631777.6941	315926.1908	Bure	2			No	No	Yes	No	6
Kings Head Wroxham	TP	630324.3578	318205.5986	Bure	3			Yes	yes	Yes	No	
Stracey Arms	TP	643849.1488	309070.0946	Bure	2			Yes	Yes	No	No	35
The New Inn	TP	634094.2565	317345.488	Bure	2			Yes	No	No	No	8
Anchor Moorings	TP	628008.2032	319433.6613	Bure	2							
The Shed	TP	630263.6889	317960.1911	Bure	3							
Landamore Marina	TP	630221.6648	318262.2048	Bure	3							

		OS Coordinates			Planning	Charging Information	Facilities					
UnitName	Responsible Party	easting	northing	River	Dark Sky Zone	Current number of Charging points	Water Point Count	Pub/eatery	Shop	Tourist Attraction	Yacht Station	Number of spaces
Salhouse Spit	TP	631695.361	315817.234	Bure	2			No	No	Yes	No	15
Salhouse Island	TP	632106.2055	315721.2623	Bure	2			No	No	Yes	No	11
Perci Island	TP	633992.9449	317491.3531	Bure	2			No	No	No	No	3
Woodbastwick	TP	634383.2524	316448.0982	Bure	2			No	No	No	No	5
Horning Pleasurecraft	TP	634680.5525	316578.5593	Bure	2							
Horning Church	TP	635545.8058	316352.7551	Bure	2			No	No	No	No	2
Upton Parish Staithe	TP	640312.8895	312806.7197	Bure	2			Yes	No	No	No	7
Pedros/Horizon Craft	TP	641184.7573	311663.8954	Bure	2			Yes	Yes	No	No	38
Mill House Farm	TP	641349.26	310882.0692	Bure	2			Yes	No	No	No	8
Belaugh Church	TP	628834.7086	318404.0726	Bure	2			No	No	No	No	1
Lay-by moorings for Yarmouth Bridges	BA	651783.6508	308003.0138	Breydon	3	0	0					
Sutton Staithe 1	BA	638181.18	323705.7255	Ant	2	2	2	Yes	No	No	no	8

		OS Coordinates			Planning	Charging Information	Facilities					
UnitName	Responsible Party	easting	northing	River	Dark Sky Zone	Current number of Charging points	Water Point Count	Pub/eatery	Shop	Tourist Attraction	Yacht Station	Number of spaces
Paddy's Lane	BA	635893.4388	322510.7279	Ant	2	0	0	No	No	No	No	15
Barton Turf Staithe	BA	635720.6412	322486.4802	Ant	2	0	0	No	No	No	No	5
Sutton Staithe 2	BA	638064.0497	323689.0178	Ant	2	0	0	Yes	No	No	No	15
Gayes Staithe	BA	635047.1454	321045.6814	Ant	2	0	1	No	No	No	No	11
How Hill	BA	637017.8852	318906.0813	Ant	2	0	0	No	No	Yes	No	28
Neatishead Staithe	BA	634462.2981	321027.1192	Ant	2	2	1	Yes	No	No	No	12
Wayford Bridge	BA	634853.778	324837.9896	Ant	2	0	0	Yes	No	No	No	5
Dilham Staithe	BA	633221.6607	325551.3574	Ant	2	2	0	No	No	No	No	5
Irstead Staithe	BA	636621.5967	320513.3276	Ant	2	1	0	Yes	No	No	No	2
Horning Marshes	BA	637137.1492	317180.9962	Ant	2	0	0	Yes	Yes	No	No	22
Stalham Staithe	BA	637292.9831	324710.7977	Ant	2	0	0	Yes	Yes	Yes	No	4
Vintage Wooden Boat Co.	TP	634658.1587	324838.2767	Ant	2			yes	No	No	No	20

**Table A7.8: Data held on moorings in the Broads**

		OS Coordinates			Planning	Charging Information	Facilities					
UnitName	Responsible Party	easting	northing	River	Dark Sky Zone	Current number of Charging points	Water Point Count	Pub/eatery	Shop	Tourist Attraction	Yacht Station	Number of spaces
Wayford Marina	TP	634961.7336	324773.66	Ant	2			Yes	No	No	No	
Richardsons Visitors	TP	637325.8055	324347.15	Ant	2	Available	Available	Yes	yes	yes	No	
Irstead Parish	TP	636627.4363	320504.1084	Ant	2			No	No	No	No	1
EA moorings Ludham Bridge	TP	637210.9212	317126.7662	Ant	2			Yes	Yes	No	No	10
Horning Church Farm	TP	637363.6562	316953.6434	Ant	2				Treated as single unit with mooring below as adjacent			
Horning Hall Cottages	TP	637419.4838	316921.6567	Ant	2			Yes	Yes	No	No	
Pleasure Boat	TP	640972.7547	322511.0368		1			Yes	No	No	No	10

## Appendix 8 - Costed components list

Table A8.1 below, details the components we have specified for implementing the demonstration in both its marine and shoreside components.

<b>Table A8.1: Breakdown of costs for proposed demonstration</b>					
<b>Index</b>	<b>COSTS</b>	<b>3 YEAR TOTAL</b>	<b>2022</b>	<b>2023</b>	<b>2024</b>
<b>1</b>	<b>Retrofit equipment</b>				
1.1	Labour - Installation	£25,000	£10,000	£15,000	
1.2	Subcontracting - Installation	£13,000	£5,000	£8,000	
1.3	Drivetrain and Power Distribution - See Table A8.2 Below	£98,600	£98,600	£0	
1.4	Propeller	£400		£400	
1.5	Electric hot taps - 3 @ £233	£700		£700	
1.6	Recirculating shower 2 @ £4,500	£9,000		£9,000	
1.7	Space heaters	£3,000		£3,000	

<b>Table A8.1: Breakdown of costs for proposed demonstration</b>					
<b>Index</b>	<b>COSTS</b>	<b>3 YEAR TOTAL</b>	<b>2022</b>	<b>2023</b>	<b>2024</b>
1.8	Electric oven/hob	£500		£500	
	<b>Sub-Total</b>	<b>£150,200</b>	<b>£113,600</b>	<b>£36,600</b>	<b>£0</b>
<b>2</b>	<b>Shoreside Infrastructure 10 x 7kW and 1 x 22kW AC Fast Charger</b>				
	<i>Grid Connection Costs to UKPN</i>				
2.1	NBD Boatyard, Wroxham connection cost	£2,000		£2,000	
2.2	Berney Arms connection cost	£22,000		£22,000	
2.3	GY Yacht Station connection cost	£2,000		£2,000	
2.4	Norwich Yacht Station connection cost	£2,000		£2,000	
2.5	Beccles Yacht Station connection cost	£10,000		£10,000	
2.6	Reedham Yacht Station connection cost	£12,000		£12,000	

<b>Table A8.1: Breakdown of costs for proposed demonstration</b>					
<b>Index</b>	<b>COSTS</b>	<b>3 YEAR TOTAL</b>	<b>2022</b>	<b>2023</b>	<b>2024</b>
2.7	Ranworth Staithe connection cost	£17,000		£17,000	
2.8	Potter Heigham connection cost	£17,000		£17,000	
2.9	Acle Bridge	£2,000		£2,000	
2.10	Upper Ant connection cost	£22,000		£22,000	
2.11	St. Benet's Abbey connection cost	£32,000		£32,000	
	<b>Sub-Total</b>	<b>£140,000</b>	<b>£0.00</b>	<b>£140,000.00</b>	<b>£0.00</b>
2.12	Feeder Cabinets (Green GRP cabinets, including fitting)	£15,400		£15,400	
2.13	Switchgear (Overcurrent protection, Surge protection, metering)	£11,000		£11,000	
2.14	Cabling (AC 5 core 6 sq mm - allow 100m per site)	£5,500		£5,500	
2.15	Concrete base and mounting post	£8,470		£8,470	

<b>Table A8.1: Breakdown of costs for proposed demonstration</b>					
<b>Index</b>	<b>COSTS</b>	<b>3 YEAR TOTAL</b>	<b>2022</b>	<b>2023</b>	<b>2024</b>
2.16	Groundworks (allow 100m @£160 per metre)	£176,000		£176,000	
2.17	Communications hardware (includes 1 year back office subscription)	£8,3070	£2,700	£2,970	£2,700
2.18	7kW EVSE - AC Supply posts	£27,890		£27,890	
2.19	22kW EVSE - AC Supply Post	£3,300		£3,300	
2.20	Installation Labour	£5,500		£5,500	
2.21	Infrastructure Project Management	£4,400		£4,400	
	<b>Sub-Total</b>	<b>£265,830</b>	<b>£2,700.00</b>	<b>£260,430.00</b>	<b>£2,700.00</b>
<b>3</b>	<b>DATA LOGGING EQUIPMENT (Delta-T quotation) ex VAT</b>				
3.1	Data loggers X2 (control and demo boats) @£1500 each	£3,000		£3,000	
3.2	Wifi dongle to connect logger to local 4G-connected Wifi network X2	£120		£120	
	<b>Sensors</b>				

<b>Table A8.1: Breakdown of costs for proposed demonstration</b>					
<b>Index</b>	<b>COSTS</b>	<b>3 YEAR TOTAL</b>	<b>2022</b>	<b>2023</b>	<b>2024</b>
3.3	Current shunts @£35 each	£210		£210	
3.4	Current transformers 230V 20A @£35 each	£420		£420	
3.5	Thermistors @£10 (pack of two)	£50		£50	
3.6	Water flow sensors @£60 each	£480		£480	
3.7	Fuel flow sensor @£100	£100		£100	
3.8	Cabling and connectors	£500		£500	
	<b>Sub-Total</b>	<b>£4,880</b>	<b>£0.00</b>	<b>£4,880.00</b>	<b>£0.00</b>
<b>4</b>	<b>ENERGY/FUEL COSTS</b>				
4.1	Diesel (control boat)	£3,000		£3,000	
4.2	Electricity Cost (Demonstration Boat)	£2,500		£2,500	
	<b>Sub-Total</b>	<b>£5,500</b>	<b>£0.00</b>	<b>£5,500.00</b>	<b>£5,500.00</b>

<b>Table A8.1: Breakdown of costs for proposed demonstration</b>					
<b>Index</b>	<b>COSTS</b>	<b>3 YEAR TOTAL</b>	<b>2022</b>	<b>2023</b>	<b>2024</b>
<b>5</b>	<b>NON-FUEL OPERATING COSTS</b>				
5.1	Labour (Revenue)	£3,000		£1,500	£1,500
5.2	Costs of data analysis	£3,000		£1,500	£1,500
5.3	Cost of provision of boat for retrofitting	£20,000		£20,000	
5.5	Project and Financial Management and Reporting	£117,600	£33,600	£50,400	£33,600
	<b>Sub-Total</b>	<b>£143,600</b>	<b>£33,600.00</b>	<b>£73,400.00</b>	<b>£36,600.00</b>
<b>6</b>	<b>CONTINGENCY</b>	£73,000	£15,000	£54,000	£4,000
<b>7</b>	<b>GRAND TOTAL</b>	<b>£783,010</b>	<b>£164,900</b>	<b>£574,810</b>	<b>£43,300</b>

<b>Table A8.2: Further Breakdown of Drivetrain and Power Distribution Costs included in Table A8.1</b>					
<b>Item Number</b>	<b>Item description</b>	<b>QTY</b>	<b>Supplier</b>	<b>Approximate cost</b>	<b>Lead time</b>
1	Socket	1	MENNEKES	£150.00	1 week
2	Onboard charger 22kW	1	TORQEEDO	£8,500.00	6-8 weeks
3	Charger distribution Box	1	TORQEEDO	£1,000.00	6-8 weeks
4	12V Starter Battery	1	VARIOUS	£200.00	1-2 weeks
5	Main distribution box	1	TORQEEDO	£6,700.00	6-8 weeks
6	Battery System 40 kWh with cooling and venting kit	1	TORQEEDO	£25,000.00	6-8 weeks
7	Battery System 40 kWh with cooling and venting kit	1	TORQEEDO	£25,000.00	6-8 weeks
8	Main Propulsion Motor	1	TORQEEDO	£11,000.00	6-8 weeks
9	12V Battery System	1	VARIOUS	£500.00	1-2 weeks
10	Bow Thruster Motor System	1	AR PEACHMENT	£1,800.00	3 weeks
11	Installation labour/commissioning and further design	1	TORQEEDO	£10,000.00	-
12	Extra load AC Distribution, Inverters and distribution boards	1	VARIOUS	£6,000.00	2-3 weeks
13	Cabling	1	VARIOUS	£1,500.00	1-2 weeks
14	Cooling systems	1	VARIOUS	£1,250.00	2-3 weeks
<b>TOTAL</b>				<b>£98,600.00</b>	<b>8 weeks</b>

## Appendix 9 - User experience, social and economic impacts evaluation

We hope to prove that electrically powered inland cruisers are a viable option for the decarbonisation of the Broads by conducting a real-world demonstration. Conducting a real-world demonstration is a crucial step towards decarbonising the Broads. Whilst the feasibility study has shown that switching to electricity as a single energy source for marine vessels is possible, several user experience, social, and economic factors must be considered and tested. We can only learn the true impact of switching to electricity by conducting a real-world demonstration, gathering and analysing both quantitative and qualitative data.

Boating on the Broads is primarily a leisure experience, and it is a choice made by holidaymakers and private boat owners alike who enjoy boating as a pastime. Therefore, we must consider how switching to an alternative energy source may impact this experience – and ultimately impact the choices made by holidaymakers and private boat owners. The areas of impact that will be studied in user experience surveys, include:

- User Experience
  - Re-fuelling / Recharging experience
  - Range anxiety
  - Heating the craft
  - Cooking
  - Handling and performance
  - Perception of Safety
- Economic
  - Cost of boat ownership, including retrofitting and purpose built
  - Cost of hiring electric cruisers
  - Supply of electricity and hydrogen potentially in the future
- Social Impacts
  - Noise pollution
  - Mooring availability
  - Emissions
  - Fuel leaks

A detailed description of our reasons for examining the above aspects of the user experience is given below:

### User experience

Boating is ultimately a leisure experience, and ensuring that the user experience remains one which boaters will enjoy is crucial to the success of the project. As such, we'll consider the impacts of the changes to user experience in this section.

### *Re-fuelling and recharging*

Currently, all inland holiday cruisers are powered by fossil fuels. The biggest change to the user experience of hiring or using an electrically powered cruiser will be the requirement to recharge. Hire cruisers are usually fuelled by the boatyard during their turnaround process, unlike private craft which are fuelled as required by their owners. It is not common for hire customers to participate in the refuelling process. Electric cruisers will require more frequent charging, resulting in the requirement for the customer to conduct the re-charging process, and to moor where charging points are available.

The impact on the customer's holiday, therefore, is that possible mooring locations will be limited and more time will need to be spent 'maintaining' the boat for use. There is also a higher likelihood of the cruiser running out of energy during a hire, which is likely to create a feeling of "range anxiety". A common complaint of hire customers is the inability to find a suitable mooring, and this is likely to contribute to increased anxiety.

Hire craft are not permitted to cruise at night, and proposed with this demonstration are dedicated electric craft charging locations with charge connectors unique to MEVs (preventing a diesel craft from occupying an ECP when seeking an electrical hook-up). A real-world demonstration will help to establish whether range anxiety is felt at all, and if the dedicated mooring locations alleviate these concerns.

### *Heating*

The most common method of heating inland motor cruisers is via warm air heating through forced convection. The benefit of doing so is that the air inside the vessel quickly heats and makes the occupants feel warm. Electrically powered heating methods often use radiation, physical conduction, and natural convection, resulting in less uniform heat distribution. Feedback from cruiser holiday customers often concerns the efficacy of heating in colder months.

A real-world demonstration of electrically powered heating systems, such as the proposed infrared panel heaters, will help establish whether the difference in systems impacts how comfortable the occupants feel and, thus, the viability of operating electrically powered cruisers during cooler months.

### *Cooking*

Cooking aboard inland cruisers is usually conducted via the use of gas-burning appliances. However, electric appliances have been used for cooking for many years in domestic settings, and there is no question that electric appliances can replace gas-powered appliances aboard a cruiser from the perspective of useability and familiarity – especially if induction hobs are used, which provide more rapid heat than traditional hobs.

### *Handling and performance*

The experience of driving a cruiser is impacted by the type of propulsion method used. The use of an electrically powered motor is likely to change the feel of how a cruiser handles. This difference is due to how quickly the vessel can convert stored energy into motion. Those who've driven both electric and fossil-fuelled cars will be familiar with the differences in handling. As cruisers are primarily leisure craft, how the craft handles will directly impact the enjoyment of the experience.

### *Perception of safety*

The key consideration here is how safe the customer feels aboard the cruiser. Whilst conducting a leisure activity, safety is a crucial aspect of the enjoyment of the experience. Many of the alterations required to convert an inland cruiser to use electricity exclusively will result in improved safety - for instance, the emission of harmful gases from cooking appliances and the requirement to interact with toxic chemicals such as diesel fuel. There are, however, other areas where risks will be increased, such as risks of electrocution and the potential risk of fire during a collision. It is unlikely that the above changes will alter the user's perception of safety. However, there is also the safety risk of running out of energy during cruising, which may impact the user's perception of how safe the activity is.

### *Economic*

#### *Cost of boat ownership*

There are several elements to the cost of boat ownership which the switch to electricity will impact. Chief amongst these is the cost of the cruiser due to the cost of the components, notably the batteries. There will also be the requirement to replace the batteries. The initial investment in the batteries is not likely to be entirely offset by reduced energy costs within the battery's lifetime.

Conversely, there will be reduced costs in servicing, engine maintenance replacement, and so on associated with fossil fuel-powered cruisers.

The difference in cost of ownership of electric cruisers will need to be measured throughout the proposed demonstration, with a comparison made to the cost of ownership of a diesel-powered control vessel. As the success of the decarbonisation goal depends partly upon the overall costs over time, these will be presented as part of our evaluation.

#### *Cost of hire*

Boat hire companies exist to make a profit. As such, the costs involved in operating a hire cruiser will be factored into the price the customer pays to hire the cruiser. Whilst boatyards will benefit from reduced energy and servicing costs, switching to electricity will incur the considerable expense of replacing batteries every 10 years or so. These costs will need to be passed on to the customer to ensure that the business model of hiring cruisers remains economically viable. There are two considerations:

- a) Will customers pay more to hire an electrically powered cruiser?

- b) Can an electrically powered cruiser be operated at the same or lower cost than a traditionally powered cruiser?

### Social Impacts

The change in energy source will also have several impacts, including

- Noise pollution
- Mooring availability
- Emissions
- Fuel leaks

Electrically powered cruisers will produce less noise than their diesel counterparts, which is likely to be well received by both the hirer/owner and other river users.

They won't produce emissions, which is also likely to be considered an advantage by both the hirer/owner and other river users - as boats will no longer be emitting fumes whilst moored or cruising, which would otherwise be inhaled by those nearby.

Electric cruisers will also have no possibility of fuel leaks, which are harmful to the hirer/owner, environment and wildlife.

However, there is a key social consideration of mooring availability. Whilst the proposed demonstration would involve just one cruiser with dedicated moorings - there is always the possibility of other river users obstructing moorings, and when more electric craft are available for hire on the Broads, competition for popular mooring spots will become a further consideration. The proposed demonstration will help the industry to understand the social challenges that may be faced due to the competition for mooring locations.

## Appendix 10: Demonstration delivery timescales

In Table A10.1 below, we present an abridged version of the Gantt to reveal only the scope of work made up of tasks, milestones and stage gates for the proposed demonstration. A supplementary document accompanies this report with the full project plan as a Gantt chart (see Gantt\_10008242.pdf).

<b>Table A10:1 Scope of work for proposed demonstration</b>					
<b>Task Number</b>	<b>Task</b>	<b>Owner</b>	<b>Duration</b>	<b>Approx Start</b>	<b>Approx End</b>
<b>Phase 1 - Project preparation</b>					
<b>0</b>	<b>Project administration</b>			1/Sep/22	1/Nov/22
0.1	Confirm project funding and Go-date	UKRI/DfT		1/Sep/22	7/Sep/22
0.2	Define detailed project plan - times, priority actions and dependencies	Partners	4w	1/Sep/22	31/Sep/22
0.3	Project initiation: set up accounting system; meeting agendas; risk management system; etc.	Partners	Full project	1/Sep/22	31/Sep/22
<b>1</b>	<b>Marine planning</b>			1/Sep/22	1/Nov/22
1.1	Confirm project partners and suppliers' lead times	Partners	1w	1/Sep/22	7/Sep/22
1.2	Confirm service subcontractors	Partners	1w	8/Sep/22	15/Sep/22
1.3	Plan demonstration and control vessel data management systems	Partners	4w		
1.4	Plan RV & CV component removal & Installations	NBD/partners	2w	1/Sep/22	31/Sep/22
<b>2</b>	<b>Shoreside planning and surveying</b>			1/Sep/22	7/Dec/22
2.1	Confirm retrofit components, parts list and costs	Ren/NBD	3w	1/Sep/22	21/Sep/22
2.2	Procure subcontractor design and development time	Partners/Torqueedo	1w	1/Sep/22	7/Sep/22
2.3	Lead time for ordering component parts	Suppliers	12w	1/Sep/22	7/Dec/22

2.4	Survey intended ECP installation sites	Subcontractor	4w	1/Nov/22	30/Nov/22
2.5	Apply to BA for permissions to install ECPs	BA	8w	1/Nov/22	31/Dec/22
2.6	Ask UKPN for permission to upgrade ground infrastructure	UKPN	8w	1/Nov/22	31/Dec/22
2.7	Plan charger management and payments systems	BA	4w	1/Dec/22	31/Dec/22
<b>3 Marketing and advertising</b>				1/Sep/22	1/Nov/22
3.1	Plan and execute retrofit vessel (RV) marketing campaign	NBD/subcontractor	4w	1/Oct/22	1/Nov/22
3.2	List RV for hire	NBD	1w	1/Nov/22	1/Nov/22
3.3	Plan and execute ETB2 project publicity	Partners	3w	1/Oct/22	21/Oct/22
3.4	Design customer orientation course for RV operation	NBD	1w	21/Nov/22	28/Nov/22
<b>M1</b>	Milestone 1: Subcontractors are arranged; lead times confirmed; components on order; confident Phase 2 can be delivered on schedule			11/01/22	
<b>SG1</b>	Stage gate 1: Good to proceed to Phase 2			11/01/22	
<b>Phase 2 - Project development</b>					
<b>4 Demonstration vessels</b>				1/Nov/22	31/Mar/23
4.1	Lift retrofit vessel (RV) from water and select control vessel (CV)	NBD	1w	1/Nov/22	7/Nov/22
4.2	Remove RV drivetrain	NBD	2w	7/Nov/22	21/Nov/22
4.3	Remove RV ancillary systems	NBD	2w	7/Nov/22	21/Nov/22
4.4	Install new RV powertrain	NBD/partners	5w	1/Dec/22	21/Jan/23
4.5	Install new RV ancillary systems	NBD/partners	5w	1/Dec/22	21/Jan/23
4.6	Install data acquisition systems - RV and CV	NBD/partners	3w	14/Dec/22	21/Jan/22
4.7	Rebuild any interior components - RV	NBD	4w	21/Jan/23	21/Feb/23
4.8	Return RV to water and test systems on both vessels	NBD	1w	21/Feb/23	28/Feb/23

4.9	Test and commission RV and CV	NBD	1w	1/Mar/23	7/Mar/23
4.10	Snagging & Slack	NBD	3w	7/Mar/23	31/Mar/23
<b>M2</b>	Milestone 2: Demonstration vessel ready to commence demonstration			31/Mar/23	
<b>5</b>	<b>Boatyard Charging</b>			1/Nov/22	31/Mar/23
5.1	Execute groundworks for charger	NBD/Subcontractor	2w		
5.2	Install charger	Subcontractor	1w		
5.3	Connect charger & testing	Subcontractor/UKPN	1w		
5.4	Commission charger for service	Subcontractor	1w		
5.5	Snagging & Slack	Subcontractor	2w		
<b>M3</b>	Milestone 3: Boatyard charger ready for demonstration			31/Mar/23	
<b>6</b>	<b>Mooring/Navigation Charging</b>			1/Nov/22	8/Apr/23
6.1	Execute groundworks for chargers	Subcontractor	10w	1/Nov/22	31/Jan/23
6.2	Execute UKPN groundworks	UKPN	10w	1/Nov/22	31/Jan/23
6.3	Install chargers	Subcontractor	2w	1/Feb/23	14/Feb/23
6.4	Connect chargers and testing	Subcontractor	2w	14/Feb/23	28/Feb/23
6.5	Install and test charger management system	BA/NBD	1w	21/fe/23	28/Feb/23
6.6	Install & Test Payment system integration with BA Finance system	BA	3w	1/Mar/23	21/Mar/23
6.7	Commission chargers for service	Sub/UKPN	1w	21/Mar/23	31/Mar/23
6.8	Snagging & slack	Subcontractor	1w	21/Mar/23	31/Mar/23
<b>M4</b>	Milestone 4: Shoreside chargers are ready for use in demonstration			31/Mar/23	
6.9	All systems test: RV navigates to all chargers	Partners	1w	1/Apr/23	7/Apr/23
<b>SG2</b>	<b>Stage gate 2: Good to proceed to Phase 3 with customer use</b>			8/Apr/23	
<b>Phase 3 - Run demonstration</b>					

7	Hire RV and CV for holidays			1/Apr/23	31/Oct/23
7.1	Take bookings	NBD	Pre-Season & Season		
7.2	Run orientation course for RV hirers	NBD	Season		
7.3	Monitor shoreside charging systems	BA/NBD	Season		
7.4	Collect operational data on RV and CV	Partners	Season		
7.5	Monitor and maintain RV performance	NBD	Season		
7.6	Operate charger management system	BA/NBD	Season		
7.7	Collect user experience and economics data (surveys)	NBD/BA	Season		
<b>M5</b>	Milestone 5: Phase 2 marine demonstration completed			31/Oct/23	
<b>SG3</b>	Stage gate 3: Good to proceed to Phase 4			31/Oct/23	
<b>Phase 4 - Data analysis and reporting</b>					
8	Analyse data			1/Nov/23	31/Mar/24
8.1	Analyse operational and environmental data	Partners	34w	1/Apr/23	14/Dec/23
8.2	Analyse user data	Partners	3w	1/Nov/23	21/Nov/23
8.3	Analyse economics data	Partners/Subs	3w	1/Nov/23	21/Nov/23
9	Project reporting & Planning future rollout			1/Nov/23	31/Mar/24
9.1	Create final report	Partners	12w	20/Dec/23	31/Mar/24
9.2	Phase 2+ Planning	Partners	20w	1/Nov/23	31/Mar/24
9.3	Deliver final report on demonstration outcomes	Partners	20w	2/Nov/23	1/Apr/24
<b>M6</b>	Milestone 6: Final Phase 2 report delivered			1/Apr/24	

## Appendix 11 - Applied examples of maritime decarbonisation

Here we explore some of the projects looking at decarbonisation of recreational vessels and the policy levers that have been deployed.

### Electrifying Amsterdam's Canals

Amsterdam is decarbonising the city through stringent policy change, which encompasses all forms of transport including its canals. In 2013, the City of Amsterdam declared net zero emission status requiring private and smaller boats to be electric by 2020 and larger commercial vessels (20 meter plus) to be emission free by 2025. A ban was later introduced on the use of two stroke outboard engines which pre-date 2007 on private boats by 2017 and on commercial vessels by 2020<sup>76</sup>. Further regulation aimed at incentivising change is in place, including a 'Groen Vignet' (green licence) for mooring in the canals, which is 0.3 times the cost of a red licence for petrol or diesel engines.

The introduction of Amsterdam's Clean Air Strategy (2019) enacted a ban on diesel powered passenger craft and municipal ferries on Amsterdam waterways by 2025.<sup>77</sup> In March 2020, an article by Safety4Sea reported 75% of the 550 commercial vessels on Amsterdam's canals had already transitioned to become electric.<sup>78</sup> The majority of vessels are undergoing retrofitting to batteries and electric drivetrains as they come up for maintenance. Retrofitting is estimated to add an additional 33% to the usual cost of maintenance, and this cost increases for older boats.<sup>79</sup> The transition for the commercial sector, including hire boat operators is an easier transition as the costs associated with retrofitting the vessels can be factored into the overall business costs and passed onto the end consumer.

Conversely, it is estimated that only 5% of Amsterdam's 12,000 recreational boats, which are mostly smaller privately-owned vessels, are electric.

Canal boats also play a significant role in the transition, as they constitute Amsterdam's most popular tourist attraction, each in use up to 10-14 hours per day. However, it's their duration of use which makes them more challenging to retrofit due to the size of battery capacity necessary to prevent the need to charge throughout the day<sup>80</sup>.

The city government has worked closely with contractors to ensure onshore infrastructure comprising over 100 charging stations is available by the end of 2021. This will be supported by a floating battery which sits atop a barge to supply mobile energy storage generated from rooftop solar panels in the port area, as well as energy from wind and biomass.<sup>81</sup>

<sup>76</sup> <https://inlandwaterwaysinternational.org/amsterdam-2013-2025-electrification-of-all-canal-traffic/>

<sup>77</sup> <https://www.amsterdam.nl/en/policy/sustainability/clean-air/>

<sup>78</sup> <https://safety4sea.com/amsterdam-canal-boats-go-electric-ahead-of-2025-diesel-ban/>

<sup>79</sup> <https://www.carbontrust.com/resources/a-roadmap-for-the-decarbonisation-of-the-european-recreational-marine-craft-sector>

<sup>80</sup> <http://www.ppmc-transport.org/zero-emissions-for-canal-cruise-boats-by-2025/>

<sup>81</sup> <https://www.maritime-executive.com/article/amsterdam-launches-floating-battery-service>

### Decarbonising vessels on the Seine

The navigation authority for the Seine in Paris, the *Communauté Portuaire de Paris*, have agreed a deadline of 2030 to achieve fossil-free operations, for both road vehicles and the fleet of 150 boats.<sup>82</sup> The CPP has implemented a voluntary programme that supports boat owners through the transition process. The authority recognises that the capex cost of retrofitting existing vessels is extremely high and for some stakeholders, greater than the value of the vessel itself. As such, public funds are being made available to cross-subsidise some of the conversion activities.

French company Naviwatt has been selected as a partner to provide services to vessel owners around optimum retrofit system designs. Their website advises that they will undertake a detailed study of each boat in order to design a tailor-made solution for every case. They also analyse usage patterns and fuel consumption to establish the propulsion capacity required.

### Norway's National Action Plan

The Norwegian government's Action Plan for Green Shipping (2019) provides another example of how government policy is driving decarbonisation within the maritime sector. This action plan is particularly relevant to this study as it recognises the potential of recreational craft to make a tangible contribution towards decarbonisation of the maritime sector.

According to Norway's emissions inventory, emissions from recreational craft total 53,000 tonnes of CO<sub>2</sub>e, or around 0.4% of Norway's total transport sector emissions (2017 data). Norwegian households own more than 600,000 recreational vessels, of which 400,000 are motorboats without accommodation.

The Norwegian government's Action Plan for Shipping sets out an ambition to halve emissions from domestic shipping by 2030. The current carbon tax applies to petrol and diesel for use as a fuel in recreational craft, which are also subject to the road use duty and the basic tax on mineral oil, respectively. The government has committed to increasing the carbon tax rate by 5% per year between 2020 and 2025. It also outlines a commitment to review emissions from recreational craft and the emission reduction potential, and consider policy instruments to promote zero and low emission solutions.<sup>83</sup>

### Plymouth MeLL Clean Maritime Demonstration Competition (CMDC) Project

The project comprises a consortium of city partners to create Plymouth's Marine e-Charging Living Lab (MeLL), to provide onshore infrastructure required to accelerate clean maritime innovation and growth for Plymouth. Led by the University of Plymouth in partnership with Plymouth City Council, Princess Yachts Limited and Aqua SuperPower, the project will secure Plymouth the status of becoming the first city in the UK to install a network of shoreside charging facilities.

Funded as part of the Clean Maritime Development Fund by the Department for Transport and delivered in partnership with Innovate UK, the project will identify suitable locations for charging

---

<sup>82</sup> <https://www.cpp.paris/post/transition-%C3%A9cologique-en-marche-sur-la-seine-et-les-canaux>

<sup>83</sup> <https://www.regjeringen.no/contentassets/2ccd2f4e14d44bc88c93ac4effe78b2f/the-governments-action-plan-for-green-shipping.pdf>

facilities that can be easily linked to the National Grid. It will also develop and deploy an array of sensor technologies that can assess the environmental and operational impacts of e-charging.<sup>84</sup> It is hoped the project will complement existing and emerging initiatives including Oceansgate, Smart Sound Plymouth, the Plymouth Freeport and the UK's first National Marine Park.

---

<sup>84</sup><https://www.plymouth.ac.uk/news/plymouth-to-host-uks-first-charging-network-for-electric-maritime-vessels>